

MELSEC **WS** series

Safety Controller User's Manual

-WS0-CPU0
-WS0-CPU1
-WS0-CPU3
-WS0-XTDI
-WS0-XTIO
-WS0-4RO

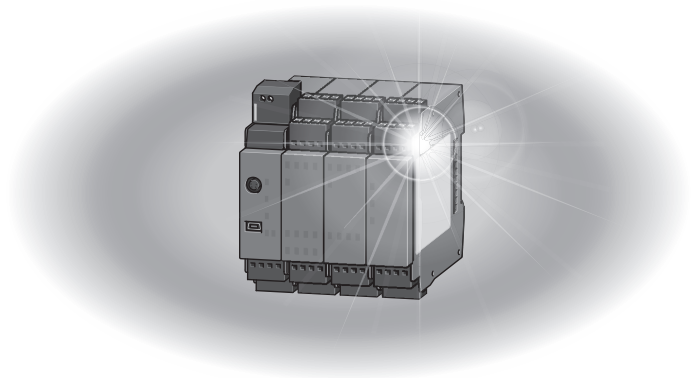

Powered by
SICK

MELSEC-WS series products were jointly developed and manufactured by Mitsubishi and SICK AG, Industrial Safety Systems in Germany.
* Note that the warranty on MELSEC-WS series products differs from that on MELSEC-Q or MELSEC-QS series products.
(Refer to "WARRANTY" written in this manual.)

This document is protected by the law of copyright, whereby all rights established therein remain with the company Mitsubishi Electric Corporation. Reproduction of this document or parts of this document is only permissible within the limits of the legal determination of Copyright Law. Alteration or abridgement of the document is not permitted without the explicit written approval of the company Mitsubishi Electric Corporation.

Precautions regarding warranty and specifications

MELSEC-WS series products are jointly developed and manufactured by Mitsubishi and SICK AG, Industrial Safety Systems, in Germany.

Note that there are some precautions regarding warranty and specifications of MELSEC-WS series products.

<Warranty>

- The gratis warranty term of the product shall be for one (1) year after the date of delivery or for eighteen (18) months after manufacturing, whichever is less.
- The onerous repair term after discontinuation of production shall be for four (4) years.
- Mitsubishi shall mainly replace the product that needs a repair.
- It may take some time to respond to the problem or repair the product depending on the condition and timing.

<Specifications>

- General specifications of the products differ.

	MELSEC-WS	MELSEC-Q	MELSEC-QS
Operating ambient temperature	-25 to 55°C*1	0 to 55°C	0 to 55°C
Operating ambient humidity	10 to 95%RH	5 to 95%RH	5 to 95%RH
Storage ambient temperature	-25 to 70°C	-25 to 75°C	-40 to 75°C
Storage ambient humidity	10 to 95%RH	5 to 95%RH	5 to 95%RH

*1 When the WS0-GCC100202 is included in the system, operating ambient temperature will be 0 to 55 °C.

- EMC standards that are applicable to the products differ.

	MELSEC-WS	MELSEC-Q, MELSEC-QS
EMC standards	EN61000-6-2, EN55011	EN61131-2

• SAFETY PRECAUTIONS •

(Read these precautions before using this product.)

Before using this product, please read this manual and the relevant manuals carefully and pay full attention to safety to handle the product correctly.

In this manual, the safety precautions are classified into two levels: "⚠️ WARNING" and "⚠️ CAUTION".



Indicates that incorrect handling may cause hazardous conditions, resulting in death or severe injury.



Indicates that incorrect handling may cause hazardous conditions, resulting in minor or moderate injury or property damage.

Under some circumstances, failure to observe the precautions given under "⚠️ CAUTION" may lead to serious consequences.

Observe the precautions of both levels because they are important for personal and system safety.

Make sure that the end users read this manual and then keep the manual in a safe place for future reference.

[Design Precautions]

⚠️ WARNING

- When the MELSEC-WS safety controller detects a fault in the external power supply or itself, it turns off the outputs. Configure an external circuit so that the connected devices are powered off according to the output status (off) of the MELSEC-WS safety controller. Incorrect configuration may result in an accident.
- When a load current exceeding the rated current or an overcurrent caused by a load short-circuit flows for a long time, it may cause smoke and fire. To prevent this, configure an external safety circuit, such as a fuse.
- For safety relays, configure an external circuit using a device such as a fuse or breaker to protect a short-circuit current.
- When changing data and operating status, and modifying program of the running MELSEC-WS safety controller from the PC, configure a safety circuit in the sequence program or external to the MELSEC-WS safety controller to ensure that the entire system operates safely.
Before operating the MELSEC-WS safety controller, read the relevant manuals carefully and determine the operating procedure so that the safety can be ensured.
Furthermore, before performing online operations for the MELSEC-WS safety controller from the PC, determine corrective actions to be taken for communication errors caused by failure such as a poor contact.
- Create an interlock program using a reset button to prevent the MELSEC-WS safety controller from restarting automatically after the safety function is activated and the safety controller turns off the outputs.

CAUTION

- Ensure that an entire system using the MELSEC-WS safety controller meets the requirements for the corresponding safety category.
- The life of safety relays in the safety relay output module depends on the switching condition and/or load. Configure a system satisfying the number of switching times of the safety relays in the module.
- Do not install the communication cables together with the main circuit lines or power cables. Keep a distance of 100 mm or more between them.
Failure to do so may result in malfunction due to noise.
- If a mechanical switch such as a relay is connected to an input terminal of a safety I/O module, consider contact bounce.
- **Observe the protective notes and measures.**

Observe the following items in order to ensure proper use of the MELSEC-WS safety controller.

- When mounting, installing and using the MELSEC-WS safety controller, observe the standards and directives applicable in your country.
- The national/international rules and regulations apply to the installation, use and periodic technical inspection of the MELSEC-WS safety controller, in particular.
 - Machinery Directive 2006/42/EC
 - EMC Directive 2004/108/EC
 - Provision and Use of Work Equipment Directive 89/655/EC
 - Low-Voltage Directive 2006/95/EC
 - The work safety regulations/safety rules
- Manufacturers and owners of the machine on which a MELSEC-WS safety controller is used are responsible for obtaining and observing all applicable safety regulations and rules.
- The notices, in particular the test notices of this manual (e.g. on use, mounting, installation or integration into the existing machine controller), must be observed.
- The test must be carried out by specialized personnel or specially qualified and authorized personnel and must be recorded and documented and retraced at any time by third parties.
- The external voltage supply of the device must be capable of buffering brief mains voltage failures of 20 ms as specified in EN 60204.
- The modules of the MELSEC-WS safety controller conform to Class A, Group 1, in accordance with EN 55011. Group 1 encompasses all the ISM devices in which intentionally generated and/or used conductor-bound RF energy that is required for the inner function of the device itself occurs.
- **The MELSEC-WS safety controller fulfils the requirements of Class A (industrial applications) in accordance with the “Interference emission” basic specifications.**
The MELSEC-WS safety controller is therefore only suitable for use in an industrial environment and not for private use.

[Security Precautions]

WARNING

- To maintain the security (confidentiality, integrity, and availability) of the programmable controller and the system against unauthorized access, denial-of-service (DoS) attacks, computer viruses, and other cyberattacks from external devices via the network, take appropriate measures such as firewalls, virtual private networks (VPNs), and antivirus solutions.

[Installation Precautions]

WARNING

- Do not use the MELSEC-WS safety controller in flammable gas atmosphere or explosive gas atmosphere. Doing so may result in a fire or explosion due to such as an arc caused by switching the relays.

CAUTION

- Use the MELSEC-WS safety controller in an environment that meets the general specifications in this manual. Failure to do so may result in electric shock, fire, malfunction, or damage to or deterioration of the product.
- Latch the module onto the DIN mounting rail. Incorrect mounting may cause malfunction, failure or drop of the module.
- To ensure full electromagnetic compatibility (EMC), the DIN mounting rail has to be connected to functional earth (FE).
Ensure that the earthing contact is positioned correctly. The earthing spring contact of the module must contact the DIN mounting rail securely to allow electrical conductivity.
- Shut off the external power supply (all phases) used in the system before mounting or removing the module.
Failure to do so may result in damage to the product.
- Do not directly touch any conductive part of the module.
Doing so can cause malfunction or failure of the module.
- The MELSEC-WS safety controller is only suitable for mounting in a control cabinet with at least IP 54 degree of protection.
Failure to meet the installation method may cause the module to fail or malfunction due to the deposition of dust or the adhesion of water.

[Wiring Precautions]

WARNING

- Shut off the external power supply (all phases) used in the system before wiring. Failure to do so may result in electric shock or damage to the product. The system could start up unexpectedly while you are connecting the devices.

CAUTION

- Individually ground the GND wires of the MELSEC-WS safety controller with a ground resistance of 100 Ω or less. Failure to do so may result in electric shock or malfunction.
- Check the rated voltage and terminal layout before wiring to the module, and connect the cables correctly. Connecting a power supply with a different voltage rating or incorrect wiring may cause a fire or failure.
- Tighten the terminal screw within the specified torque range. Undertightening can cause short circuit, fire, or malfunction. Overtightening can damage the screw and/or module, resulting in drop, short circuit, or malfunction.
- Prevent foreign matter such as dust or wire chips from entering the module. Such foreign matter can cause a fire, failure, or malfunction.
- Mitsubishi MELSEC-WS safety controllers must be installed in control cabinets. Connect the main power supply to the MELSEC-WS safety controller through a relay terminal block. Wiring and replacement of an external power supply must be performed by maintenance personnel who is familiar with protection against electric shock. (For wiring methods, refer to Chapter 7.)
- Place the cables in a duct or clamp them. If not, dangling cable may swing or inadvertently be pulled, resulting in damage to the module or cables or malfunction due to poor contact.

[Startup and Maintenance Precautions]

WARNING

- Do not touch any terminal while power is on.
Doing so will cause electric shock.
- Shut off the external power supply (all phases) used in the system before cleaning the module or retightening the terminal screws. Failure to do so may result in electric shock.
Tighten the terminal screw within the specified torque range. Undertightening can cause short circuit, fire, or malfunction.
Overtightening can damage the screw and/or module, resulting in drop, short circuit, or malfunction.
- **Safety-oriented devices must be suitable for safety related signals.**
A function interruption of safety outputs results in a loss of the safety functions so that the risk of serious injury exists.
Do not connect any loads that exceed the rated values of the safety outputs.
Wire the MELSEC-WS safety controller so that 24 V DC signals cannot unintentionally contact safety outputs.
Connect the GND wires of the power supply to earth so that the devices do not switch on when the safety output line is applied to frame potential.
Use suitable components or devices that fulfill all the applicable regulations and standards.
Actuators at the outputs can be wired single-channeled. In order to maintain the respective Safety Integrity Level the lines have to be routed in such a manner that cross circuits to other live signals can be excluded, for example by routing them within protected areas such as in a control cabinet or in separate sheathed cables.

 CAUTION

- Before performing online operations (Force mode) for the running MELSEC-WS safety controller from the PC, read the relevant manuals carefully and ensure the safety.
The online operations must be performed by qualified personnel, following the operating procedure determined at designing.
Fully understand the precautions described in the Safety Controller Setting and Monitoring Tool Operating Manual before use.
- Do not disassemble or modify the modules.
Doing so may cause failure, malfunction, injury, or a fire.
Mitsubishi does not warrant any products repaired or modified by persons other than Mitsubishi or FA Center authorized by Mitsubishi.
- Shut off the external power supply (all phases) used for the MELSEC-WS safety controller before mounting or removing the module.
Failure to do so may cause the module to fail or malfunction.
- After the first use of the product, do not mount/remove the module from/to the DIN mounting rail, and the terminal block to/from the module more than 50 times (IEC 61131-2 compliant) respectively.
Exceeding the limit of 50 times may cause malfunction.
- Before handling the module, touch a grounded metal object to discharge the static electricity from the human body.
Failure to do so may cause the module to fail or malfunction.

[Disposal Precautions]

 CAUTION

- When disposing of this product, treat it as industrial waste.
Disposal of the product should always occur in accordance with the applicable country-specific waste-disposal regulations (e.g. European Waste Code 16 02 14).

● CONDITIONS OF USE FOR THE PRODUCT ●

- (1) Although Mitsubishi Electric has obtained the certification for Product's compliance to the international safety standards IEC61508, ISO13849-1 from TUV Rheinland, this fact does not guarantee that Product will be free from any malfunction or failure. The user of this Product shall comply with any and all applicable safety standard, regulation or law and take appropriate safety measures for the system in which the Product is installed or used and shall take the second or third safety measures other than the Product. Mitsubishi Electric is not liable for damages that could have been prevented by compliance with any applicable safety standard, regulation or law.
- (2) Mitsubishi Electric prohibits the use of Products with or in any application involving, and Mitsubishi Electric shall not be liable for a default, a liability for defect warranty, a quality assurance, negligence or other tort and a product liability in these applications.
 - (a) power plants,
 - (b) trains, railway systems, airplanes, airline operations, other transportation systems,
 - (c) hospitals, medical care, dialysis and life support facilities or equipment,
 - (d) amusement equipments,
 - (e) incineration and fuel devices,
 - (f) handling of nuclear or hazardous materials or chemicals,
 - (g) mining and drilling,
 - (h) and other applications where the level of risk to human life, health or property are elevated.
- (3) Mitsubishi Electric shall have no responsibility or liability for any problems involving programmable controller trouble and system trouble caused by DoS attacks, unauthorized access, computer viruses, and other cyberattacks.

REVISIONS

*The manual number is given on the bottom left of the back cover.

Print date	*Manual number	Revision
September, 2009	SH(NA)-080855ENG-A	First edition
March, 2010	SH(NA)-080855ENG-B	A new module, CC-Link interface module, was added.
July, 2011	SH(NA)-080855ENG-C	Description on Flexi Link system was added.
December, 2011	SH(NA)-080855ENG-D	Correction of errors in writing
August, 2012	SH(NA)-080855ENG-E	A new function was added to WS0-XTIO modules.
June, 2013	SH(NA)-080855ENG-F	Correction of errors in writing
August, 2014	SH(NA)-080855ENG-G	A new module, WS0-CPU3 module, was added. A new function was added to WS0-XTIO and WS0-XTDI modules. Description on Flexi Line system was added.
August, 2016	SH(NA)-080855ENG-H	Description on the corporate logo was changed
November, 2018	SH(NA)-080855ENG-I	Correction of errors in writing
March, 2021	SH(NA)-080855ENG-J	■Added or modified parts SAFETY PRECAUTIONS, CONDITIONS OF USE FOR THE PRODUCT, Section 7.1, 12.2.1, 12.2.2, 12.2.3, 12.2.4, 14.4.5
June, 2022	SH(NA)-080855ENG-K	■Added or modified parts Section 12.2.1, 12.2.2, 12.2.3, 12.2.4, 14.1
March, 2023	SH(NA)-080855ENG-L	■Added or modified parts Section 14.1, 14.2, 14.4
May, 2023	SH(NA)-080855ENG-M	■Added or modified parts Section 3.3

Japanese manual version SH-080852-M

This manual confers no industrial property rights or any rights of any other kind, nor does it confer any patent licenses. Mitsubishi Electric Corporation cannot be held responsible for any problems involving industrial property rights which may occur as a result of using the contents noted in this manual.

© 2009 MITSUBISHI ELECTRIC CORPORATION

CONTENTS

SAFETY PRECAUTIONS	1
CONDITIONS OF USE FOR THE PRODUCT	7
REVISIONS	8
CONTENTS	9
GENERIC TERMS AND ABBREVIATIONS.....	13
1. About this document	14
1.1 Function of this document.....	14
1.2 Target group.....	15
1.3 Depth of information.....	15
1.4 Scope	16
1.5 Abbreviations used	16
1.6 Symbols used.....	16
2. On safety	18
2.1 Qualified safety personnel	18
2.2 Application areas for the device.....	18
2.3 Correct use.....	19
2.4 General protective notes and protective measures	21
2.5 Environmental protection	22
2.5.1 Disposal.....	22
2.5.2 Material separation.....	22
3. Product description	23
3.1 System properties	23
3.2 System configuration	24
3.3 Version, compatibility and features.....	25
3.4 Memory plug	27
3.5 CPU module WS0-CPU0	27
3.5.1 Description.....	27
3.5.2 Display elements and terminal description.....	28
3.6 CPU module WS0-CPU1	30
3.6.1 Description.....	30
3.6.2 Display elements and terminal description.....	31
3.7 CPU module WS0-CPU3	32
3.7.1 Description.....	32
3.7.2 Display elements and terminal description.....	33
3.8 WS0-XTIO safety I/O combined module.....	34
3.8.1 Description.....	34
3.8.2 Display elements and terminal description.....	35
3.8.3 Internal circuits	36
3.8.4 Disabling the test pulses of WS0-XTIO outputs Q1 to Q4	37

3.8.5 Extended fault detection time for cross-circuits on the outputs Q1 to Q4 on the WS0-XTIO for switching loads with high capacitance ..	38
3.8.6 Single channel usage of WS0-XTIO outputs.....	39
3.9 WS0-XTDI safety input module.....	40
3.9.1 Description.....	40
3.9.2 Display elements and terminal description.....	41
3.9.3 Internal circuits	41
3.10 WS0-4RO safety relay output module	42
3.10.1 Description.....	42
3.10.2 Display elements and terminal description.....	43
4. Connecting devices	45
4.1 Safety command devices and electro-mechanical safety switches.....	48
4.1.1 Emergency stop pushbuttons (e.g. SICK ES21).....	48
4.1.2 Electro-mechanical safety switches with and without interlock	49
4.1.3 Enabling switch (e.g. SICK E100)	50
4.1.4 Two-hand control	51
4.1.5 Safety mats and bumpers	52
4.1.6 User mode switches	53
4.1.7 Potential-free contacts.....	53
4.2 Non-contact safety sensors	54
4.2.1 Magnetic safety switches (e.g. SICK RE)	54
4.2.2 Inductive safety switches (e.g. SICK IN4000 and IN4000 Direct).....	54
4.2.3 Transponder (e.g. SICK T4000 Compact and T4000 Direct).....	55
4.3 Testable single-beam photoelectric safety switches	55
4.3.1 Testable Type 2 single-beam photoelectric safety switches.....	55
4.3.2 Testable Type 4 single-beam photoelectric safety switches.....	56
4.3.3 Customized testable single beam photoelectric safety switches	57
4.3.4 Information for mounting testable single-beam photoelectric safety switches	57
4.4 Electro-sensitive protective equipment (ESPE)	59
4.5 Safety outputs Q1 to Q4	59
4.6 EFI devices	59
4.6.1 Connection of EFI devices	59
4.7 Flexi Link	60
4.7.1 Flexi Link overview	60
4.7.2 System requirements and restrictions for Flexi Link	61
4.7.3 Connection of a Flexi Link system.....	61
4.8 Flexi Line.....	64
4.8.1 Flexi Line overview.....	64
4.8.2 Connection of a Flexi Line system	64
4.9 EMC measures for Flexi Link and Flexi Line	66

5. Special functions.....	67
5.1 Enhanced Function Interface - EFI	67
5.1.1 Definition.....	67
5.1.2 Properties	67
5.1.3 Functions	68
5.1.4 Benefits.....	68
5.2 Muting	69
6. Mounting/Dismantling	70
6.1 Steps for mounting the modules	70
6.2 Steps for dismantling the modules.....	72
7. Electrical installation	73
7.1 Electrical installation requirements	73
7.2 Internal circuit power supply	78
8. Configuration	79
9. Commissioning	80
9.1 Full approval of the application	80
9.2 Tests before the initial commissioning	81
10. Diagnostics	82
10.1 In the event of faults or errors	82
10.1.1 ERROR operating states.....	82
10.2 Error displays of the status LEDs, error messages and rectification measures.....	84
10.3 Additional error displays of SICK EFI-compatible devices.....	91
10.4 Mitsubishi support	91
10.5 Extended diagnostics.....	91
11. Maintenance	92
11.1 Regular inspection of the protective device by qualified safety personnel.....	92
11.2 Device replacement.....	93
12. Technical data	94
12.1 Response times of the MELSEC-WS safety controller.....	94
12.1.1 Calculation of the response times	95
12.1.2 Min. switch off time	100
12.2 Data sheet.....	101
12.2.1 CPU modules: WS0-CPU0 , WS0-CPU1 and WS0-CPU3	101
12.2.2 WS0-XTIO safety input/output combined module	103
12.2.3 WS0-XTDI safety input module	107
12.2.4 WS0-4RO safety relay output module.....	110
12.3 Dimensional drawings	114
12.3.1 WS0-CPUx module with memory plug	114

12.3.2 WS0-XTIO module, WS0-XTDI module, and WS0-4RO module.....	114
13. Ordering information.....	115
13.1 Available modules and accessories	115
13.2 Recommended products.....	115
14. Annex	116
14.1 EC declaration of conformity.....	116
14.2 UK declaration of conformity.....	118
14.3 Manufacturers checklist.....	120
14.4 Wiring examples.....	121
14.5 Troubleshooting.....	130
14.5.1 Basics of troubleshooting	130
14.5.2 Troubleshooting flowchart (for CPU module)	131
14.5.3 Troubleshooting flowchart (for safety I/O module)	137
14.5.4 Troubleshooting flowchart (for safety relay output module)	144
14.5.5 Troubleshooting (for terminal wiring).....	147
14.6 Example for the calculation of the response time of Flexi Line	148
14.7 SICK contact	150

GENERIC TERMS AND ABBREVIATIONS

Generic term/abbreviation	Description
WS0-MPL0	The abbreviation for the WS0-MPL000201 MELSEC-WS safety controller memory plug
WS0-MPL1	The abbreviation for the WS0-MPL100201 MELSEC-WS safety controller memory plug
WS0-CPU0	The abbreviation for the WS0-CPU000200 MELSEC-WS safety controller CPU module
WS0-CPU1	The abbreviation for the WS0-CPU130202 MELSEC-WS safety controller CPU module
WS0-CPU3	The abbreviation for the WS0-CPU320202 MELSEC-WS safety controller CPU module
WS0-XTIO	The abbreviation for the WS0-XTIO84202 MELSEC-WS safety controller safety I/O combined module
WS0-XTDI	The abbreviation for the WS0-XTDI80202 MELSEC-WS safety controller safety input module
WS0-4RO	The abbreviation for the WS0-4RO4002 MELSEC-WS safety controller safety relay output module
WS0-GETH	The abbreviation for the WS0-GETH00200 MELSEC-WS safety controller Ethernet interface module
WS0-GCC1	The abbreviation for the WS0-GCC100202 MELSEC-WS safety controller CC-Link interface module
CPU module	A generic term for the WS0-CPU0, WS0-CPU1 and WS0-CPU3
Safety I/O module	A generic term for the WS0-XTIO and WS0-XTDI
Network module	A generic term for the WS0-GETH and WS0-GCC1

1 About this document

Please read this chapter carefully before working with the documentation and the MELSEC-WS system.

1.1 Function of this document

For the MELSEC-WS system there are three sets of manuals with clearly defined application as well as user's manuals (hardware) for each module.

- All the MELSEC-WS modules and their functions are described in detail in the user's manuals (hardware). Use this manual in particular for the planning of MELSEC-WS safety controllers.

The hardware manual are designed to address the technical personnel of the machine manufacturer or the machine operator in regards to safe mounting, electrical installation, commissioning as well as on operation and maintenance of the MELSEC-WS safety controller.

The hardware manual does not provide instructions for operating machines on which the safety controller is, or will be, integrated. Information on this is to be found in the manuals of the machine.

- The Safety Controller Setting and Monitoring Tool Operating Manual describes the software-supported configuration and parameterization of the MELSEC-WS safety controller. In addition the manual contains the description of the diagnostics functions that are important for operation and detailed information for the identification and elimination of errors. Use the manual in particular for the configuration, commissioning and operation of MELSEC-WS safety controllers.
- The user's manuals for each network module describe important information on the configuration of the network modules.
- The user's manuals (hardware) are enclosed with each MELSEC-WS module. They inform on the basic technical specifications of the modules and contain simple mounting instructions. Use the user's manual (hardware) when mounting the MELSEC-WS safety controller.

The following shows the relevant manuals.

Table 1:
Overview of the MELSEC-
WS manuals

Title	Number
Safety Controller User's Manual	WS-CPU-U-E (13JZ32)
Safety Controller Ethernet Interface Module User's Manual	WS-ET-U-E (13JZ33)
Safety Controller CC-Link Interface Module User's Manual	WS-CC-U-E (13JZ45)
Safety Controller Setting and Monitoring Tool Operating Manual	SW1DNN-WS0ADR-B-O-E (13JU67)
Safety Controller CPU Module User's Manual (Hardware)	WS-CPU-U-HW-E (13JZ91)
Safety Controller Safety I/O Module User's Manual (Hardware)	WS-IO-U-HW-E (13JZ92)
Safety Controller Safety Relay Output Module User's Manual (Hardware)	WS-SR-U-HW-E (13JZ93)
Safety Controller Ethernet Interface Module User's Manual (Hardware)	WS-ET-U-HW-E (13JZ95)
Safety Controller CC-Link Interface Module User's Manual (Hardware)	WS-CC-U-HW (13J209)

1.2 Target group

This manual is addressed to the planning engineers, designers and operators of systems which are to be protected by a MELSEC-WS safety controller. It also addresses people who integrate the MELSEC-WS safety controller into a machine, commission it initially or who are in charge of servicing and maintaining the unit.

1.3 Depth of information

This manual contains information on the MELSEC-WS safety controller in the following subjects:

- mounting
- electrical installation
- hardware commissioning
- error diagnostics and remedying
- part numbers
- conformity and approval

Planning and using other company's protective devices also require specific technical skills which are not detailed in this documentation.

When operating the MELSEC-WS safety controller, the national, local and statutory rules and regulations must be observed.

Note For the acquisition of Setting and Monitoring Tool, please contact your local Mitsubishi representative.

The SICK EFI-compatible devices and SICK configuration and diagnostics software CDS are the products of SICK.

For details of the SICK products, please contact your local SICK representative (see Section 14.6).

www.sens-control.com

1.4 Scope

These operating instructions are original operating instructions.

This manual is valid for all modules of the MELSEC-WS safety controller with the exception of the network modules.

This document is the original manual.

To configure and undertake diagnostics on these devices you will need version V1.7.0 or later of the Setting and Monitoring Tool. To check the version of the software, on the Extras menu select Info.

1.5 Abbreviations used

EDM	External device monitoring
EFI	Enhanced function interface = safe SICK device communication
ESPE	Electro-sensitive protective equipment (e.g. light curtains)
NC	Normally closed
NO	Normally open
OSSD	Output signal switching device
PFHd	Probability of dangerous failure per hour
SIL	Safety integrity level (safety class)
SILCL	Safety integrity level claim limit

1.6 Symbols used

Recommendation Recommendations are designed to give you some assistance in your decision-making process with respect to a certain function or a technical measure.

Note Notes provide special information on the device.

●, ✨, ○ LED symbols describe the state of a diagnostics LED. Examples:

- The LED is illuminated constantly.
- ✨ The LED is flashing.
- The LED is off.

➤ **Action** Instructions for taking action are shown by an arrow. Read carefully and follow the instructions for action.

ATTENTION!

An "ATTENTION" indicates concrete or potential dangers. It is intended to protect you from harm and help avoid damage to devices and systems.



Read warnings carefully and follow them!

Otherwise the safety function may be impaired and a dangerous state may occur.

The term "dangerous state"

The dangerous state (standard term) of the machine is always shown in the drawings and diagrams of this document as a movement of a machine part. In practical operation, there may be a number of different dangerous states:

- machine movements
- electrical conductors

- visible or invisible radiation
- a combination of several risks and hazards

2 On safety

This chapter deals with your own safety and the safety of the equipment operators.

- Please read this chapter carefully before working with the MELSEC-WS safety controller or with the machine protected by the MELSEC-WS safety controller.

2.1 Qualified safety personnel

The MELSEC-WS safety controller must be mounted, commissioned and serviced only by qualified safety personnel.

Qualified safety personnel are defined as persons who

- have undergone the appropriate technical training

and

- have been instructed by the responsible machine owner in the operation of the machine and the current valid safety guidelines

and

- are sufficiently familiar with the applicable official health and work safety regulations, directives and generally recognized engineering practice (e.g. DIN standards, VDE stipulations, engineering regulations from other EC member states) that they can assess the work safety aspects of the power-driven equipment

and

- have access to the MELSEC-WS manuals and have read and familiarized themselves with them

and

- have access to the manuals for the protective devices (e.g. light curtains) connected to the safety controller and have read and familiarized themselves with them.

2.2 Application areas for the device

The MELSEC-WS safety controller is a configurable controller for safety applications. It can be used ...

- in accordance with IEC61508 to SIL3
- in accordance with IEC 62061 to SILCL3
- in accordance with EN/ISO 13849-1 up to Performance Level e

The degree of safety actually attained depends on the external circuit, the realization of the wiring, the parameter configuration, the choice of the pick-ups and their location at the machine.

Opto-electronic and tactile safety sensors (e.g. light curtains, laser scanners, safety switches, sensors, encoders, emergency stop pushbuttons) are connected to the safety controller and are linked logically. The corresponding actuators of the machines or systems can be switched off safely via the switching outputs of the safety controller.

2.3 Correct use



The MELSEC-WS safety controller fulfills the requirements of Class A (industrial applications) in accordance with the “Interference emission” basic specifications.

The MELSEC-WS safety controller is therefore only suitable for use in an industrial environment and not for private use.

The MELSEC-WS safety controller may only be used within specific operating limits (voltage, temperature, etc., refer to the technical data in Chapter 12) in the sense of Section 2.2 and Section 7.1. It may only be used by specialist personnel and only at the machine at which it was mounted and initially commissioned by qualified personnel in accordance with the MELSEC-WS manuals.



All warranty claims against Mitsubishi Electric Corporation are forfeited in the case of any other use, or alterations being made to the software or to devices, even as part of their mounting or installation.

- Pay attention to the safety notes and protective measures of the user’s manuals (hardware) and Safety Controller Setting and Monitoring Tool Operating Manual!
 - Make sure that on the implementation of safety-related functional logic, the regulations in the national and international standards are met, in particular the control strategies and the measures for risk reduction that are stipulated for your application.
-
- The external voltage supply of the device must be capable of buffering brief mains voltage failures of 20 ms as specified in IEC 60204.
 - The MELSEC-WS safety controller may not start up normally when power is restored immediately after the external power supply has been shut off (within 5 seconds). To restore the power, wait for 5 or more seconds after power-off.
 - The modules of the MELSEC-WS safety controller conform to Class A, Group 1, in accordance with EN 55011. Group 1 encompasses all ISM devices in which intentionally generated and/or used conductor-bound RF energy that is required for the inner function of the device itself occurs.

UL/CSA applications

- Only use the following cables:
 - for spring clamp terminals: 24 to 16 AWG, copper, suitable for temperatures of 60 to 75 °C
 - for plug-in terminals: 30 to 12 AWG, copper, suitable for temperatures of 60 to 75 °C
- The plug-in terminal tightening torque must be 0.5 to 0.6 N·m.
- Use the devices only in an environment with a pollution degree of 2 or better.
- The modules shall be supplied by an isolating power source protected by an UL248 fuse, rated max. 100/V, where V is the DC supply voltage with the maximum value of 42.4 V DC, such that the limited voltage/current requirements of UL508 are met.
- Max. WS0-XTIO Q1 ... Q4 total current $I_{\text{sum}} = 3.2 \text{ A}$
- Network modules (WS0-GETH and WS0-GCC1) are intended to be used with Class 2. Therefore the CPU module must be supplied in this case with a Class 2 power source or Class 2 transformer in accordance with UL 1310 or UL 1585.

Note The safety functions are not evaluated by UL. The approval is accomplished according to UL 508, general use applications.

2.4 General protective notes and protective measures



Observe the protective notes and measures!

Please observe the following items in order to ensure proper use of the MELSEC-WS safety controller.

- Note**
- When mounting, installing and using the MELSEC-WS safety controller, observe the standards and directives applicable in your country.
 - The national/international rules and regulations apply to the installation, use and periodic technical inspection of the MELSEC-WS safety controller, in particular:
 - Machinery Directive 2006/42/EC*¹
 - EMC Directive 2004/108/EC
 - Provision and Use of Work Equipment Directive 2009/104/EC
 - Low-Voltage Directive 2006/95/EC
 - the work safety regulations/safety rules
 - Manufacturers and owners of the machine on which a MELSEC-WS safety controller is used are responsible for obtaining and observing all applicable safety regulations and rules.
 - The notices, in particular the test notices (see Chapter 9) of this manual (e.g. on use, mounting, installation or integration into the existing machine controller) must be observed.
 - The tests must be carried out by specialized personnel or specially qualified and authorized personnel and must be recorded and documented to ensure that the tests can be reconstructed and retraced at any time by third parties.
 - This manual must be made available to the user of the machine where the MELSEC-WS safety controller is used. The machine operator is to be instructed in the use of the device by qualified personnel and must be instructed to read the manual.

*1 WS0-4RO only.

2.5 Environmental protection

The MELSEC-WS safety controller has been designed to minimize environmental impact. It uses only a minimum of power and natural resources.

- At work, always act in an environmentally responsible manner.

2.5.1 Disposal

Disposal of unusable or irreparable devices should always occur in accordance with the applicable country-specific waste-disposal regulations (e.g. European Waste Code 16 02 14).

2.5.2 Material separation



Material separation may only be performed by qualified safety personnel!

Exercise care when disassembling the devices. The danger of injury is present.

Before you can turn over the devices for environmental-friendly recycling, you must separate the different materials of the MELSEC-WS module from one another.

- Separate the housing from the remaining components (especially the PCB).
- Send the separated components to the corresponding recycling centers (see the following table).

Table 2:
Overview of disposal by
component

Component	Disposal
Product	
Housing	Plastic recycling
PCBs, cables, plugs and electrical connection pieces	Electronics recycling
Packaging	
Cardboard, paper	Paper/cardboard recycling

3 Product description

This chapter provides information on the features and properties of the MELSEC-WS safety controller and describes the structure and operating principle.

3.1 System properties

Figure 1:
MELSEC-WS safety
controller

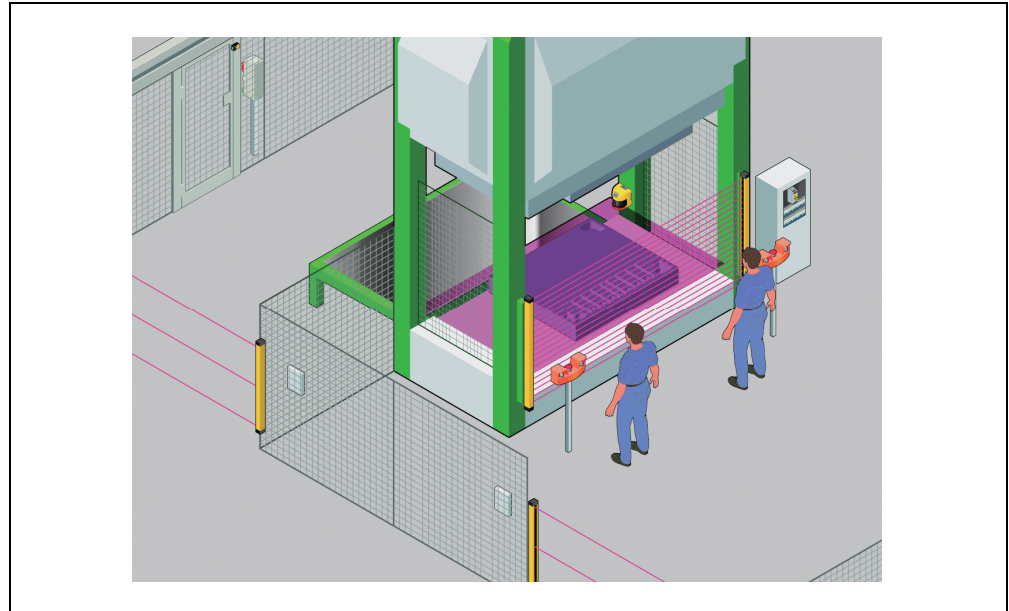

The MELSEC-WS safety controller is characterized by the following system properties:

- modular structure: 1 CPU module, up to 12 - safety I/O modules, up to 4 safety relay output modules, and up to 2 different network modules each with 22.5 mm compact width
- 8 to 96 inputs and 4 to 48 safe outputs
- programmable
- use of up to 255 standard and application-specific logic blocks
- standard logic blocks, e.g. AND, OR, NOT, XNOR, XOR
- application-specific logic blocks, e.g. emergency stop, two-hand, muting, press, ramp down, operating mode selector switch, reset, restart
- integration in different networks via network modules possible (Ethernet and CC-Link)
- 2 EFI interfaces on the WS0-CPU1 and WS0-CPU3 modules, see Section - 3.6

The Setting and Monitoring Tool is available for configuring the control tasks.

For the acquisition of Setting and Monitoring Tool, please contact your local Mitsubishi representative.

3.2 System configuration

A MELSEC-WS safety controller consists of the following modules:

- a memory plug
- CPU module
- up to 2 network modules
- up to 12 additional safety I/O modules.
- in addition up to 4 WS0-4RO safety relay output modules (meaning a max. of 16 safe relay outputs).

Figure 2:
Examples for the minimum configuration of a MELSEC-WS safety controller with WS0-CPU0 and WS0-XTDI or WS0-CPU1 and WS0-XTIO



Figure 3:
Maximum configuration of the MELSEC-WS safety controller (without safety relay output module)

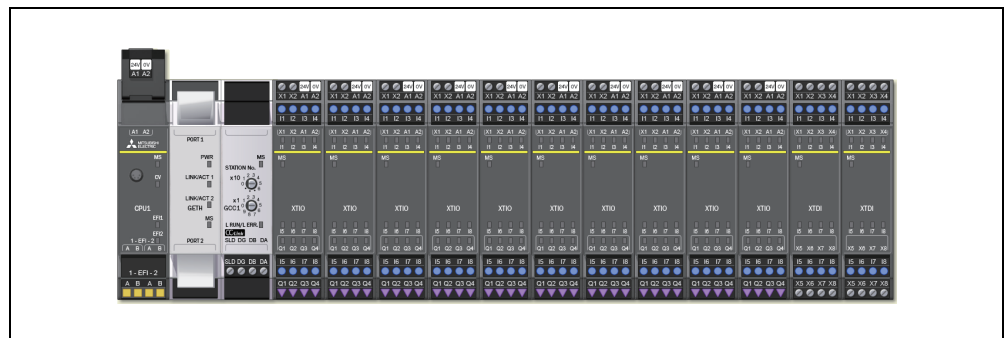

Table 3:
Overview of the modules

Type	Kind	Inputs	Outputs	Logic blocks	Max. occurrence
WS0-CPU0	CPU module	—	—	255	1×
WS0-CPU1		4 ^{*1}	—		
WS0-CPU3		4 ^{*1}	—		
WS0-XTIO	Safety I/O combined module	8	4	—	12×
WS0-XTDI	Safety input module	8	—	—	
WS0-4RO	Safety relay output module	—	4	—	4× ^{*2}
WS0-GETH	Ethernet interface module	—	—	—	2×
WS0-GCC1	CC-Link interface module	—	—	—	—

*1 EFI terminals.

*2 Max. of 16 safe relay outputs.

3.3 Version, compatibility and features

For the MELSEC-WS series several firmware versions and function packages exist that allow different functions. This section gives an overview which firmware version, which function package and/or which version of the Setting and Monitoring Tool is required to use a certain function or device.

Table 4:
Required firmware and
software versions

Feature	Minimum required firmware or software version		
	WS0-CPU	WS0-XTIO/ WS0-XTDI	Setting and Monitoring Tool
Logic offline simulation	– ^{*1}	–	V1.2.0
Logic import/export	–	–	V1.3.0
Automatic wiring diagrams	–	–	V1.3.0
Online edit	–	–	V1.3.0
Central tag name editor	–	–	V1.3.0
Flexi Link (only with WS0-CPU1/3)	V2.01 (Revision 2.xx)	–	V1.3.0
Flexi Line (only with WS0-CPU3)	V3.02 (Revision 3.xx)	–	V1.7.0
Function block documentation within the Setting and Monitoring Tool	–	–	V1.3.0
Input/output relation matrix	–	–	V1.3.0
Invertable inputs for the AND, OR, RS Flip-Flop and Routing N:N function blocks	V2.01 (Revision 2.xx)	–	V1.3.0
Ramp down detection function block	V1.11 (Revision 1.xx)	–	V1.3.0
Adjustable on-delay timer and Adjustable off-delay timer function blocks	V2.01 (Revision 2.xx)	–	V1.3.0
Fast Shutoff function block with bypass (only with WS0-XTIO)	V2.01 (Revision 2.xx)	V2.00 (Revision 2.xx)	V1.7.0
It is possible to deactivate the test signals on Q1-Q4 on the XTIO	–	V2.00 (Revision 2.xx)	V1.3.0
Verification without identical hardware possible	V2.01 (Revision 2.xx)	–	V1.0.0
Status input data and Status output data in logic	V2.01 (Revision 2.xx)	V2.00 (Revision 2.xx)	V1.3.0
Data recorder	V2.01 (Revision 2.xx) ^{*3}	–	V1.7.0
Extended cross-circuit detection time for switching loads with high capacitance	–	V3.10 (Revision 3.xx)	V1.7.0
Adjustable filter time for On-Off filters and Off-On filters on the inputs I1 to I8 on the WS0-XTIO/XTDI	–	V3.10 (Revision 3.xx)	V1.7.0

Device	Minimum required firmware or software version		
	WS0-CPU	WS0-XTIO/ WS0-XTDI	Setting and Monitoring Tool
Ethernet interface module	V1.11 (Revision 1.xx)	–	V1.2.0
CC-Link interface module	V1.11 (Revision 1.xx)	–	V1.2.1
ROHS conformity WS0-XTIO	–	Hardware version V1.01 or higher*2	–

*1 “–” means “any” or “not applicable”.

*2 All other modules from product launch onwards.

*3 The trigger setting for the data recorder is available for the CPU with V3.02 or later.

- Note**
- You can find the firmware version on the type label of the MELSEC-WS modules in the field firmware version.
 - To be able to use modules with a new firmware version, you will need a new version of the Setting and Monitoring Tool. For WS-CPU0/1 \geq V2.01 as well as WS0-XTIO/XTDI \geq V2.00 the Designer with at least V1.3.0 is required. This aspect is to be taken into account on the replacement of devices in existing systems.
 - You will find the hardware version of the MELSEC-WS modules in the hardware configuration of the Setting and Monitoring Tool in the Online state or in the report if the system was online previously.
 - The version of the Setting and Monitoring Tool can be found in the **Extras** menu under **About**.
 - For the acquisition of the newest version of the Setting and Monitoring Tool, please contact your local Mitsubishi representative.
 - The function package (Revision 1.xx or Revision 2.xx) must be selected in the Setting and Monitoring Tool hardware configuration. Function package Revision 2.xx is available with Setting and Monitoring Tool 1.3.0 and higher.
 - In order to use function package Revision 2.xx, the respective module must have at least firmware version V2.00.0. Otherwise you will receive an error message when you try to upload a configuration using Revision 2.xx to a module with a lower firmware version.
 - Newer modules are downward compatible so that any module can be replaced by a module with a higher firmware version.
 - The same firmware version and function package revision as those of the module used must be set to the new project after a project stored in the memory plug is modified.
 - You will find the device's date of manufacture at the bottom of the type label in the format yywwnnnn (yy = year, ww = calendar week, nnnn = continuous serial number in the calendar week).

3.4 Memory plug

On each CPU module there is a memory plug. The system configuration for the entire MELSEC-WS safety controller is only saved in the memory plug. On the replacement of modules this situation has the advantage that it is not necessary to re-configure that the MELSEC-WS safety controller.

There are two different variants of the memory plug that can only be used with specific CPU modules.

Table 5: Variants of the memory plug

Memory plug	Compatible CPU modules	Functions
WS0-MPL0	WS0-CPU0 WS0-CPU1	<ul style="list-style-type: none"> Electrical supply of the MELSEC-WS safety controller Storing the system configuration (without EFI-compatible devices)
WS0-MPL1	WS0-CPU3	<ul style="list-style-type: none"> Electrical supply of the MELSEC-WS safety controller Storing the system configuration (including EFI-compatible devices)

- Note**
- The CPU module, the internal logic for all modules as well as the inputs (I1...I8) and test outputs (X1...X8) on the safety I/O modules are only supplied electrically via the memory plug. On the other hand the outputs are supplied separately (Q1 to Q4, Y1 to Y6 as well as IY7 and IY8).
 - The data saved in the memory plug are also retained on an interruption in the supply of power.
 - If modules are replaced, ensure that the memory plug is reconnected to the correct CPU module. Mark all the connecting cables and plug connectors unambiguously on the MELSEC-WS safety controller to avoid confusion.
 - If you use a memory plug WS0-MPL0, then after the replacement of EFI-compatible devices connected you must configure the devices again.

3.5 CPU module WS0-CPU0

3.5.1 Description

The WS0-CPU0 module is the central process unit of the entire system in which all the signals are monitored and processed logically in accordance with the configuration stored in the memory plug. The outputs of the system are switched as a result of the processing, whereby the FLEXPBUS+ backplane bus serves as the data interface.

- Note** The CPU module WS0-CPU0 can only be operated together with the memory plug WS0-MPL0.

3.5.2 Display elements and terminal description

Figure 4:
Display elements WS0-
CPU0

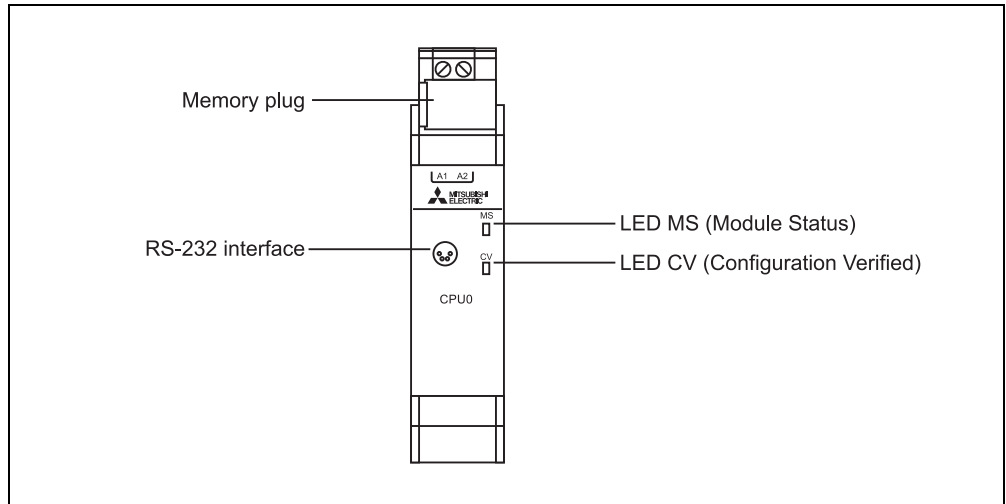

Table 6:
Displays of the MS LED on
WS0-CPU0

MS LED	Meaning	Notes
○	Supply voltage is outside range	Switch on the supply voltage and check it at the terminals A1 and A2.
⚡ Red/Green (1 Hz)	A self test is being carried out or the system is being initialized	Please wait ...
⚡ Green (1 Hz)	System is in Stop state	Start the application in the Setting and Monitoring Tool.
⚡ Green (2 Hz)	Identify (e.g. for Flexi Link)	–
● Green	System is in Run state	–
⚡ Red (1 Hz)	Invalid configuration	Check the module type and version of the CPU module and safety I/O modules whose MS LED flashes ⚡ Red/green. If appropriate, adapt the configuration using the Setting and Monitoring Tool. For detailed information refer to the Setting and Monitoring Tool, Diagnostics view.
⚡ Red (2 Hz)	Critical error in the system, possibly in this module. Application is stopped. All outputs are switched off.	Switch the supply voltage off and on again. If the error is not eliminated after multiple repetition, replace this module. For detailed diagnostics information refer to the Setting and Monitoring Tool.
● Red	Critical error in the system, possibly in another module. Application is stopped. All outputs are switched off.	Switch the supply voltage off and on again. If the error is not eliminated after multiple repetition, replace the module which displays ⚡ Red (2 Hz). If this is not the case, use the diagnostic functions of the Setting and Monitoring Tool to narrow down the respective module.

Table 7:
Displays of the CV LED on
WS0-CPU0

CV LED	Meaning	Note
○	Configuration in progress	–
⚡ Yellow (2 Hz)	Storing of configuration data in the non-volatile memory	Supply voltage may not be interrupted until the storage process has been completed.
⚡ Yellow (1 Hz)	Unverified configuration	Verify configuration with the Setting and Monitoring Tool.
● Yellow	Verified configuration	–

Table 8:
Memory plug pin
assignment

Pin	Assignment
A1	24 V voltage supply for all the modules, with the exception of the outputs (Q1...Q4)
A2	GND of the voltage supply

RS-232 interface

The CPU module furthermore has an RS-232 interface with the following functions:

- Transferring the configuration from the Setting and Monitoring Tool to the memory plug
- Uploading the configuration from the memory plug to the Setting and Monitoring Tool
- Diagnostics of the MELSEC-WS safety controller with the Setting and Monitoring Tool

Table 9:
Pin assignment of the
RS-232 interface on WS0-
CPU0

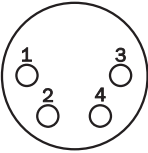
Plug/socket	Pin	Signal	Color	Assignment PC-sided RS-232 D-Sub (9 pins)
	1	Reserved	Brown	–
	2	RxD	White	Pin 3
	3	GND (Internally electrically connected with connection A2 of the CPU module)	Blue	Pin 5
	4	TxD	Black	Pin 2

- Note**
- If the RS-232 interface at the CPU module is connected permanently for usage as an alternative to a network module, the maximum permissible cable length is 3 m.
 - Avoid ground loops between the GND of the RS-232 interface and the connection A2 of the CPU module, e.g. by using optocouplers.

3.6 CPU module WS0-CPU1

3.6.1 Description

The WS0-CPU1 module has the same functions as the WS0-CPU0. Please observe the notes in Section 3.6.

- Note** The CPU module WS0-CPU1 can only be operated together with the memory plug WS0-MPL0.

In addition this module has 2 EFI interfaces. If SICK EFI-compatible devices are connected, the following additional functions can be used:

- Transferring the configuration from the Setting and Monitoring Tool to the memory plug and to the connected SICK EFI-compatible devices
- Uploading the configuration from the memory plug and the connected SICK EFI-compatible devices to the Setting and Monitoring Tool
- Diagnostics of the MELSEC-WS safety controller and the connected SICK EFI-compatible devices with the Setting and Monitoring Tool
- Process data exchange between CPU module and SICK EFI-compatible devices.
- Connection of up to four WS0-CPU1 modules as a Flexi Link system (see Section 4.7).

For further information about EFI interfaces refer to Section 5.1.

3.6.2 Display elements and terminal description

The displays of the MS and CV LEDs as well as the pin assignment of the RS-232 interface are identical with those of the WS0-CPU0, see Section 3.5.2.

Figure 5:
Display elements
WS0-CPU1

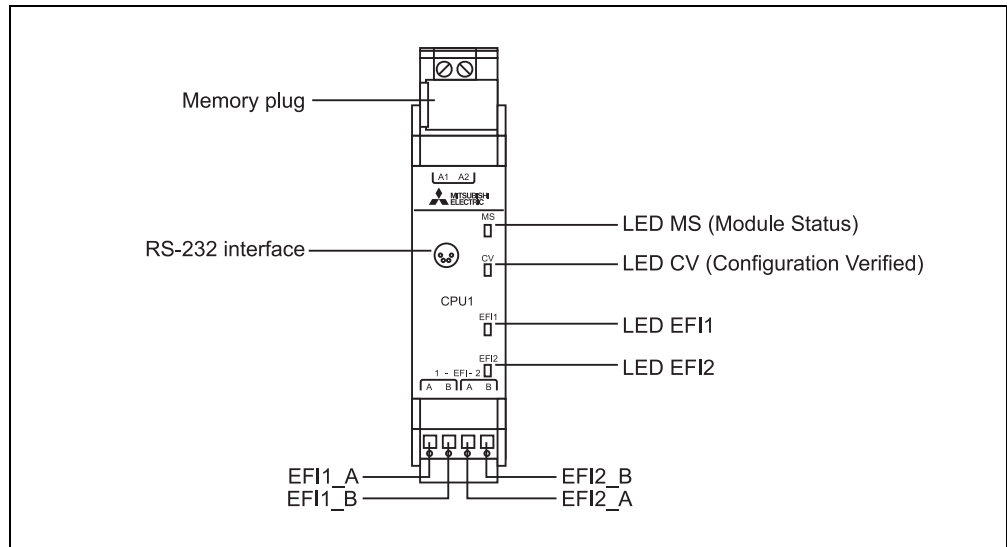

Table 10:
Displays of the EFI LEDs on
WS0-CPU1

EFI LED (EFI1 or EFI2)	Meaning	Note
○	OK	–
● Red	Waiting for integration of any SICK EFI-compatible device or Flexi Link station after power up	–
⊛ Red (1 Hz)	Error, e.g.: <ul style="list-style-type: none"> Any expected SICK EFI-compatible device or Flexi Link station not found within 3 minutes Integration check failed Communication interruption SICK EFI-compatible device address conflict Flexi Link ID conflict 	Check the wiring. Later integration is still possible.
⊛ Red (2 Hz, alternating)	Identify, (e.g. for Flexi Link)	–

3.7 CPU module WS0-CPU3

3.7.1 Description

The CPU module WS0-CPU3 has the same functions as the CPU module WS0-CPU1. Please observe the notes in Section 3.7.

In addition this module has a Flexi Line interface that permits the safe networking of up to 32 MELSEC-WS stations (see Section 4.8).

Note The CPU module WS0-CPU3 can only be operated together with the memory plug WS0-MPL1.

3.7.2 Display elements and terminal description

The indications on the MS and CV LEDs as well as the terminal assignment for the RS-232 interface are identical to the CPU module WS0-CPU3 (see section 3.5.2). The indications on the EFI1 and EFI2 LEDs are identical to the CPU module WS0-CPU1 (see section 3.6.2).

Figure 6:
Display elements
WS0-CPU3

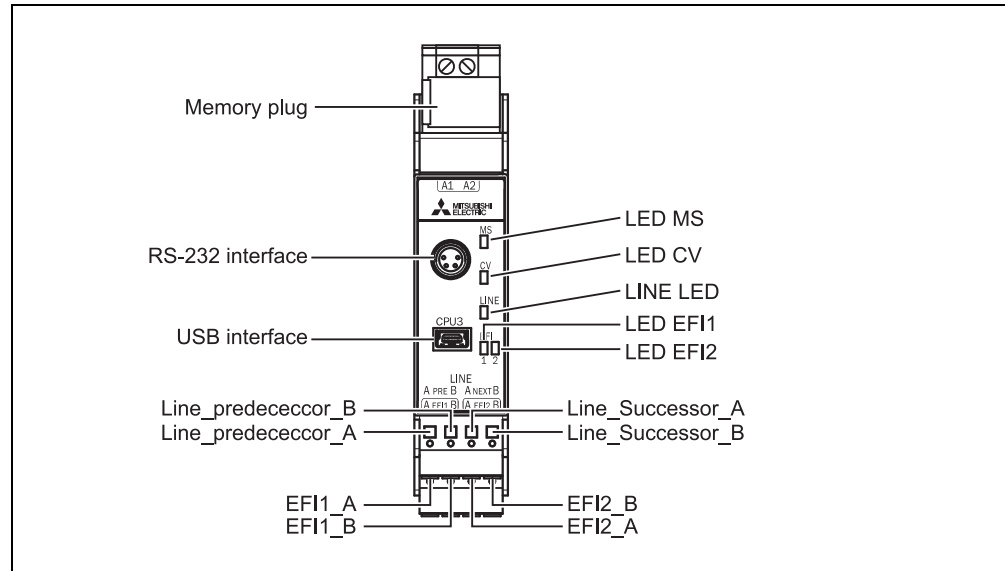

Table 11:
Displays of the EFI LEDs on
WS0-CPU3

LINE LED	Meaning
○	Flexi Line not configured and not in operation
● Green	Flexi Line in operation
☼ Green (1 Hz)	Flexi Line started, waiting for neighboring stations
☼ Green (2 Hz)	Teaching required
☼ Red/Green (2 Hz)	Flexi Line configuration required
☼ Red(1 Hz)	Error on the Flexi Line bus, e.g. communication interrupted
● Red	Critical fault, Flexi Line stopped

USB interface

WS-CPU3 module furthermore has a USB interface with the following functions:

- Transferring the configuration from the Setting and Monitoring Tool to the memory plug
- Uploading the configuration from the memory plug to the Setting and Monitoring Tool
- Diagnostics of the MELSEC-WS safety controller with the Setting and Monitoring Tool

3.8 WS0-XTIO safety I/O combined module

3.8.1 Description

The WS0-XTIO module is an input/output extension with 8 safe inputs and 4 safe outputs. It has two test signal generators: One for test output X1 and one for test output X2.

- The WS0-XTIO module offers the following functions:
- Monitoring of the connected safety devices, also refer to Chapter 4.
- Passing on the input information to the CPU module
- Receiving the control signals from the CPU module and corresponding switching of the outputs
- Fast shut-off: Direct shut-down of the actuators connected to the module possible from firmware version V1.11.0 on the CPU module CPU0 or CPU1 as well as with all firmware versions on the CPU module CPU3. Version V1.2.0 or later of the Setting and Monitoring Tool required for this purpose.

This feature significantly reduces the response time of the overall system. For switching off outputs, only 8 ms have to be added to the response times of the devices connected to the inputs and outputs. The response time on the FLEXBUS+ backplane bus as well as the logic execution time are irrelevant in this case. See also Section 12.1.

- Enabling or disabling of test pulses for outputs Q1 to Q4 with firmware version V2.00.0 or higher and Setting and Monitoring Tool version V1.3.0 or higher.

The WS0-XTIO module cannot be used alone and always requires a WS0-CPU0 or WS0-CPU1 module. See the Safety Controller Setting and Monitoring Tool Operating Manual.

The simultaneous use of several WS0-XTIO modules is possible, see Section 3.2.

Voltage for the internal logic and the test outputs is supplied from the memory plug via the FLEXBUS+ backplane bus.

Voltage for the WS0-XTIOs outputs Q1...Q4 must be supplied directly via A1/A2 on the respective module.

- Note**
- Short-circuits between test signal generators on MELSEC-WS safety controller I/O module are detected, also between test signal generators on different modules, provided the test gaps are ≤ 4 ms and the test periods are ≥ 200 ms for the relevant test outputs.
 - Short circuits to 24 V DC (stuck at high) at inputs connected to test outputs are detected independently of the test gap time.

3.8.2 Display elements and terminal description

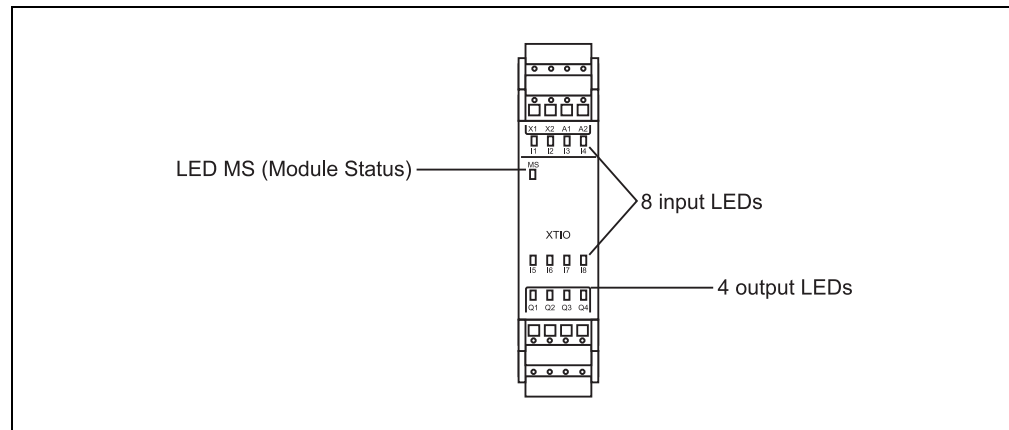
Figure 7:
Display elements
WS0-XTIOTable 12:
Terminal assignment
WS0-XTIO

Terminal	Assignment
X1/X2	Test outputs 1 and 2
I1...I4	Safe inputs 1 to 4
A1	24 V
A2	GND
I5...I8	Safe inputs 5 to 8
Q1...Q4	Outputs 1 to 4

MS LED	Meaning	Notes
○	Supply voltage is outside range	Switch on the supply voltage and check it at the terminals A1 and A2.
☼ Red/green (1 Hz)	With firmware V1.xx.0: Invalid configuration	–
	With firmware ≥ V2.00.0: Recoverable external error	Check the wiring of the flashing inputs and outputs. If all output LEDs flash, check the supply voltage at terminals A1 and A2 of this module.
☼ Green (1 Hz)	System is in Stop state	Start the application in the Setting and Monitoring Tool.
● Green	System is in Run state	–
☼ Red (1 Hz)	With firmware V1.xx.0: Recoverable external error	Check the wiring of the flashing inputs and outputs. If all output LEDs flash, check the supply voltage at terminals A1 and A2 of this module.
	With firmware ≥ V2.00.0: Invalid configuration	–
☼ Red (2 Hz)	With firmware ≥ V2.00.0: Critical error in the system, possibly in this module. Application is stopped. All outputs are switched off.	Switch the supply voltage off and on again. If the error is not eliminated after multiple repetition, replace the module. For detailed diagnostics information refer to the Setting and Monitoring Tool ., Diagnostics view.
● Red	With firmware V1.xx.0: Critical error in the system, possibly in this module or another module. Application is stopped. All outputs are switched off.	Switch the supply voltage off and on again. If the error is not eliminated after multiple repetition, replace the module which displays ☼ Red (2 Hz). If this is not the case, use the diagnostic functions of the Setting and Monitoring Tool to narrow down the respective module.
	With firmware ≥ V2.00.0: Critical error in the system, possibly in another module. Application is stopped. All outputs are switched off.	

Table 13:
Displays of the MS LED

Table 14:
Displays of the input/output
LEDs on WS0-XTIO

Input LEDs (I1...I8) Output LEDs (Q1...Q4)	Meaning
○	Input/output is inactive.
● Green	Input/output is active.
⊛ Green (1 Hz) synchronous with the red MS LED	Input/output is inactive and there is a correctable error.
⊛ Green (1 Hz) alternating with the red MS LED	Input/output is active and there is a correctable error.

Note The input and output LEDs display the states with a refresh rate of approx. 64 ms.

3.8.3 Internal circuits

Figure 8:
Internal circuits WS0-XTIO
safe inputs and test outputs

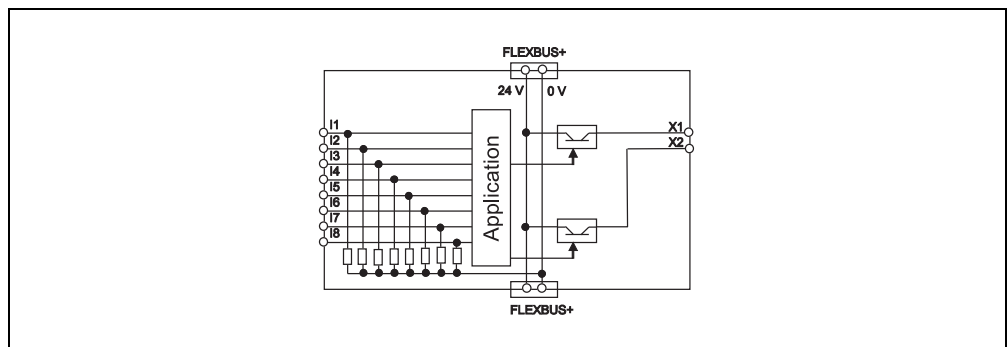
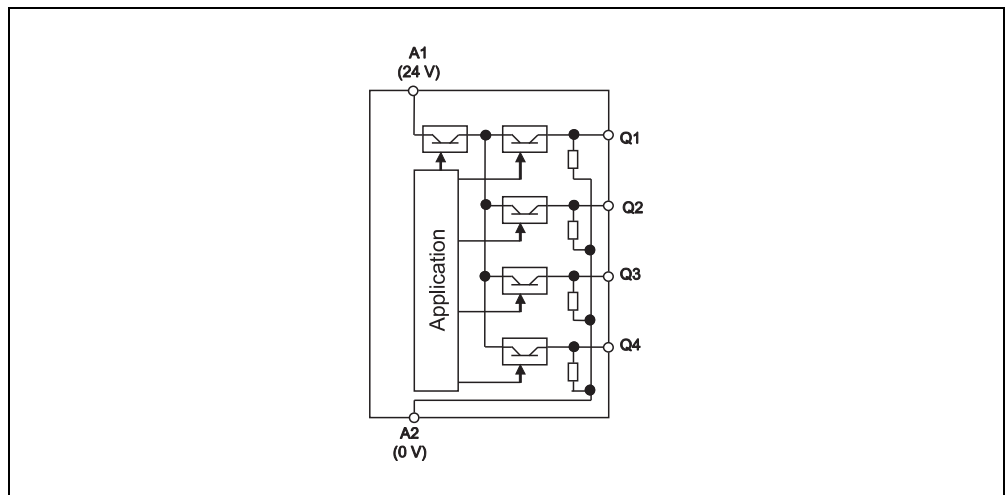

Figure 9:
Internal circuits WS0-XTIO
outputs Q1 to Q4



3.8.4 Disabling the test pulses of WS0-XTIO outputs Q1 to Q4

It is possible to disable the test pulses on one or several outputs of WS0-XTIO modules with firmware version V2.00.0 and higher.



Disabling the test pulses of any output reduces the safety parameters of all outputs!

Disabling the test pulses of one or more outputs of an WS0-XTIO module will reduce the parameters for all outputs Q1 to Q4 of this module. Consider this to ensure that your application conforms to an appropriate risk analysis and avoidance strategy!

For detailed information on the safety parameters see chapter 12.

Use protected or separate cabling!

If you disable the test pulses of one or more outputs Q1 to Q4, you have to use protected or separate cabling for the outputs with disabled test pulses, because a short circuit to 24 V can not be detected if the output is High. This could inhibit the switch-off capability for the other outputs in case of an internal detected hardware failure due to reverse powering.

Perform cyclic tests if the test pulses of any safety output are disabled!

If you disable the test pulses of one or more safe outputs Q1 to Q4, at least once per year either all outputs without test pulses have to be switched off at the same time for at least one second as a result of the logic program of the CPU module. Alternatively a power reset of the safety controller has to be performed.

How to disable the test pulses of an XTIO output Q1 to Q4:

- Connect an output element to the WS0-XTIO module.
- Double-click the output element using the left mouse button.
- Deactivate the option **Enable test pulses of this output**. The test pulses of this output are switched off. A notice will be displayed in the hardware configuration area under the respective WS0-XTIO module.

3.8.5 Extended fault detection time for cross-circuits on the outputs Q1 to Q4 on the WS0-XTIO for switching loads with high capacitance

From firmware version V3.10 it is possible to configure an extended fault detection time for cross-circuits for the outputs Q1 to Q4 on WS0-XTIO modules.

This configuration can be necessary for switching loads on which there is a cross-circuit fault immediately after switching off (change from high to low) with a normal fault detection time because the voltage at the load does not drop to the low level as quickly as expected. Examples of such cases are:

- Loads with higher capacitance than permitted as standard for the output, e.g. the supply voltage for programmable controller output cards for safety-related switching.

For this application the test pulse for the output must also be deactivated (see section 3.8.4).

- Inductive loads that cause an overshoot in the positive voltage range after the induction voltage has decayed.

Table 15:
Maximum extended fault detection times for cross-circuits on WS0-XTIO

WS0-XTIO firmware Version	Option for switching loads with high capacitance	Maximum time to low level ($\leq 3.5\text{ V}$) allowed after switching off the output (Q1 to Q4)
$\leq V2.xx$	Not possible	3 ms
$\geq V3.10$	Deactivated	3 ms
	Activated	43 ms

The capacitance beyond the value that is permitted for the output as standard must be discharged to the low level in the customer's installation after switching off the output. If this condition is not met within the maximum time allowed, there will be a cross-circuit fault on the output independent of whether the test pulses on this output are activated or deactivated.



ATTENTION

Pay attention to the suitability of the programmable controller output card for the safety-related shut down of the outputs by switching the supply voltage!

The safety-related shut down capability can be affected or even lost as a result of the following faults:

- Undetected cross-circuit on an output on the programmable controller output card that can result in the reverse supply of the programmable controller output card. In some circumstances this fault can be excluded by laying wiring in an adequately protected area.
- Undetected fault on the programmable controller output card that can result in the external supply of the programmable controller output card by another live signal.
- Extension of the response time by a buffer capacitor in the supply for the programmable controller output card.

Please note that the outputs on the WS0-XTIO modules cannot discharge this buffer capacitor, as it is normally behind a reverse polarization protection diode.

How to activate the option for switching loads with high capacitance on output Q1 to Q4 on the WS0-XTIO:

- Connect an output element to the WS0-XTIO module.
- Double-click the output element using the left mouse button.
- Select the **Enable switching extended capacitive loads with this output** option.



ATTENTION

Note the increased error detection time!

Activating the option for switching loads with high capacitance increases the error detection time. This applies primarily to single-channel outputs.

See also Section 3.8.6.

3.8.6 Single channel usage of WS0-XTIO outputs



ATTENTION

Take into account possible brief switching to high on signal-channel outputs!

In the case of an internal hardware fault outputs Q1 to Q4, which would normally be low, may briefly switch to high until the fault is detected, and there is a response to the fault. The fault detection time plus the fault reaction time is dependent on the configuration selected for the output.

WS0-XTIO firmware version	Activation of the switching of loads with high capacitance	Error detection time + error response time
≤ V2.xx	Not possible	≤ 10 ms
≥ V3.10	Deactivated	≤ 10 ms
	Activated	≤ 50 ms

Take into account this aspect in your risk analysis and risk reduction strategy, above all for single-channel outputs. Otherwise the operator of the machine will be in danger.

3.9 WS0-XTDI safety input module

3.9.1 Description

The WS0-XTDI module is the input extension with 8 safe inputs. It offers the following functions:

- monitoring of the connected sensor equipment, also refer to Chapter 4.
- passing the input information to the CPU module

The WS0-XTDI module cannot be used alone and always requires a main CPU module.

The simultaneous use of several WS0-XTIO modules is possible, see Section 3.2.

Voltage for the internal logic and the test outputs is supplied from the memory plug via the FLEXBUS+ backplane bus.



Limited short-circuit recognition!

A WS0-XTDI has two test signal generators. One test signal generator is responsible for the odd-numbered test outputs X1, X3, X5 and X7, the other for the even-numbered test outputs X2, X4, X6 and X8.

Short-circuits between test signal generators on module are detected, also between test signal generators on different modules, provided the test gaps are ≤ 4 ms and the test periods are ≥ 200 ms for the relevant test outputs. Short circuits to 24 V DC (stuck at high) at inputs connected to test outputs are detected independently of the test gap time.

Please be aware that at the WS0-XTDI the odd-numbered test outputs X1, X3, X5 and X7 are connected to one common test signal generator and that the even-numbered test outputs X2, X4, X6 and X8 are connected to another common test signal generator. Therefore short circuits between test outputs X1, X3, X5 and X7 cannot be detected. The same applies respectively for test outputs X2, X4, X6 and X8.

- Take this into consideration during the wiring (e.g. separate routing, sheathed cables)!

3.9.2 Display elements and terminal description

The displays of the MS LED as well as the input LEDs I1...I8 are identical with those of the WS0-XTIO, see Section 3.7.2.

Figure 10:
Display elements WS0-XTDI

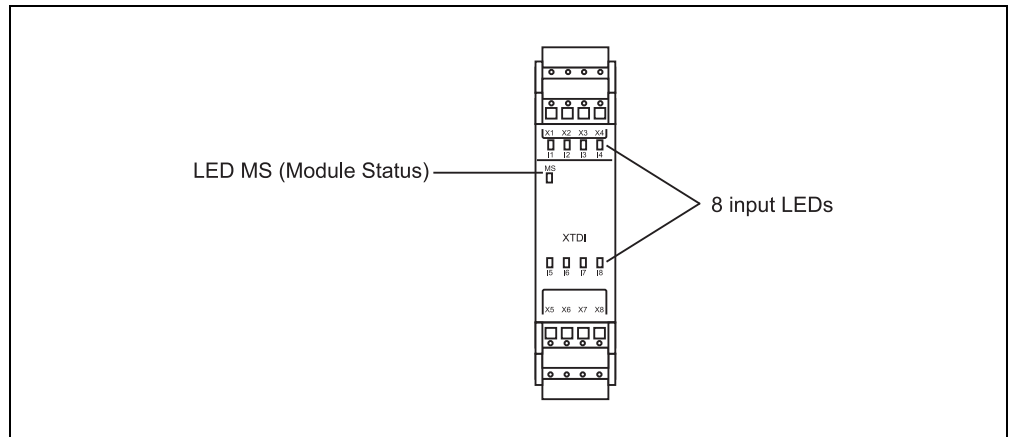
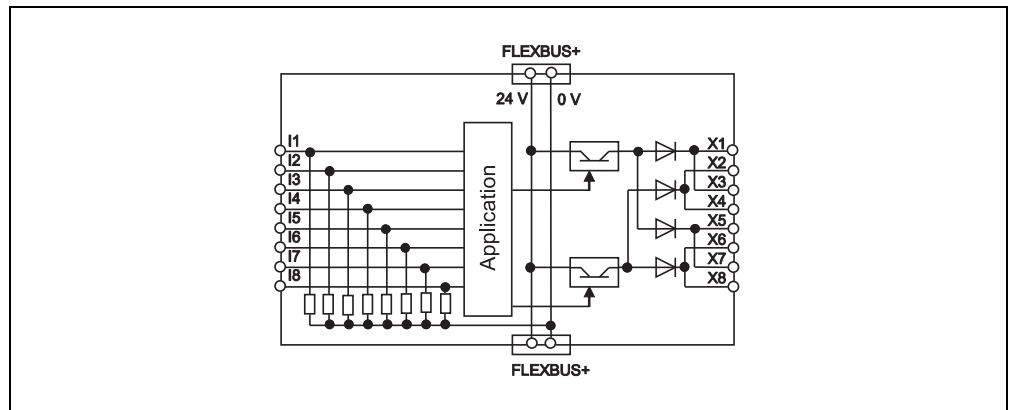

Table 16:
Terminal assignment
WS0-XTDI

Terminal	Assignment
X1/X3	Test output 1 (test signal generator 1)
X2/X4	Test output 2 (test signal generator 2)
I1...I4	Safe inputs 1 to 4
I5...I8	Safe inputs 5 to 8
X5/X7	Test output 1 (test signal generator 1)
X6/X8	Test output 2 (test signal generator 2)

3.9.3 Internal circuits

Figure 11:
Internal circuits WS0-XTDI –
safe inputs and test outputs



3.10 WS0-4RO safety relay output module

3.10.1 Description

The WS0-4RO safety relay output module provides dual-channel contact-based outputs with positively guided relay contacts.

The WS0-4RO safety relay output module cannot be used independently, but need to be switched via a WS0-XTIO module. To this purpose a control output of the WS0-XTIO module (Q1...Q4) has to be jumpered to a control input of the relay output module (B1, B2), see the following figure.

Figure 12:
Example of the inclusion of
a relay output module in the
MELSEC-WS safety
controller

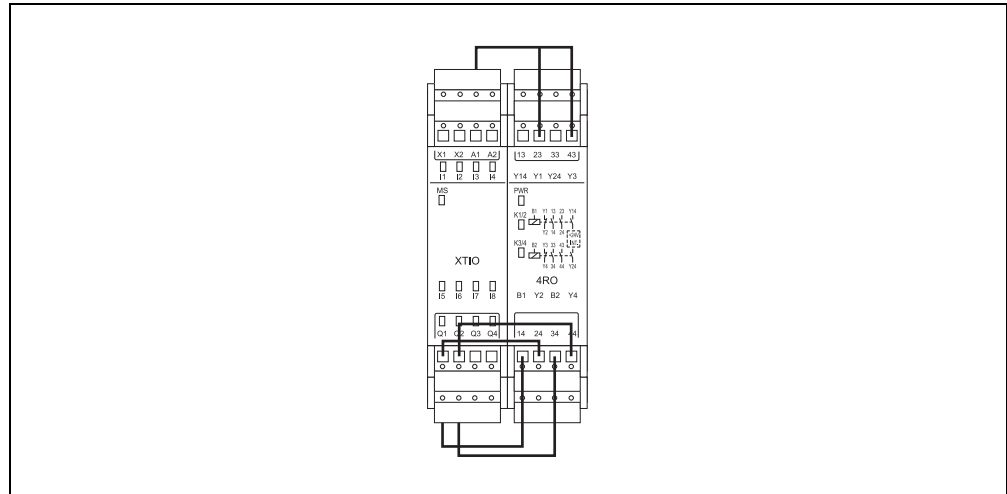

Monitor the feedback contacts using an EDM function block!

It is not sufficient to connect the control outputs B1 or B1/B2. Additionally, the feedback contacts Y1/Y2 and Y3/Y4 on the WS0-4RO safety relay module must be monitored using an EDM function block in the Setting and Monitoring Tool logic editor.

Note The safety relay output module is not participating at the FLEXBUS+ backplane bus communication. Control signals can therefore not be received from the CPU module. A max. of four WS0-4RO safety relay output modules can be connected to a MELSEC-WS safety controller, i.e. a maximum of 16 safe relay outputs are available.

WS0-4RO

The WS0-4RO has two control inputs (B1, B2). These control two times two internal relays that provide two independently redundant switch-off paths.

Control input (B1) controls two internal relays and provides a redundant switch-off path consisting of:

- two safe enabling circuits (13/14, 23/24), dual-channel and potential-free,
- a signaling circuit (Y14), dual-channel and connected to internal 24 V DC,
- a feedback EDM (Y1/Y2), dual-channel and potential-free.

Control input (B2) controls two internal relays and forms a redundant switch-off path consisting of:

- two safe enabling circuits (33/34, 43/44), dual-channel and potential-free,
- a signaling circuit (Y24), dual-channel and connected to internal 24 V DC,
- a feedback EDM (Y3/Y4), dual-channel and potential-free.

Figure 13:
Internal configuration
WS0-4RO

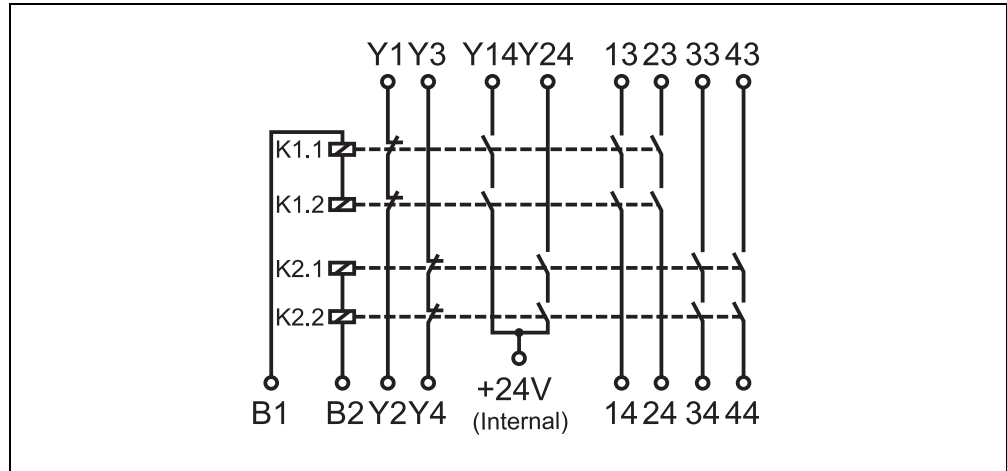

3.10.2 Display elements and terminal description

Figure 14:
WS0-4RO display elements

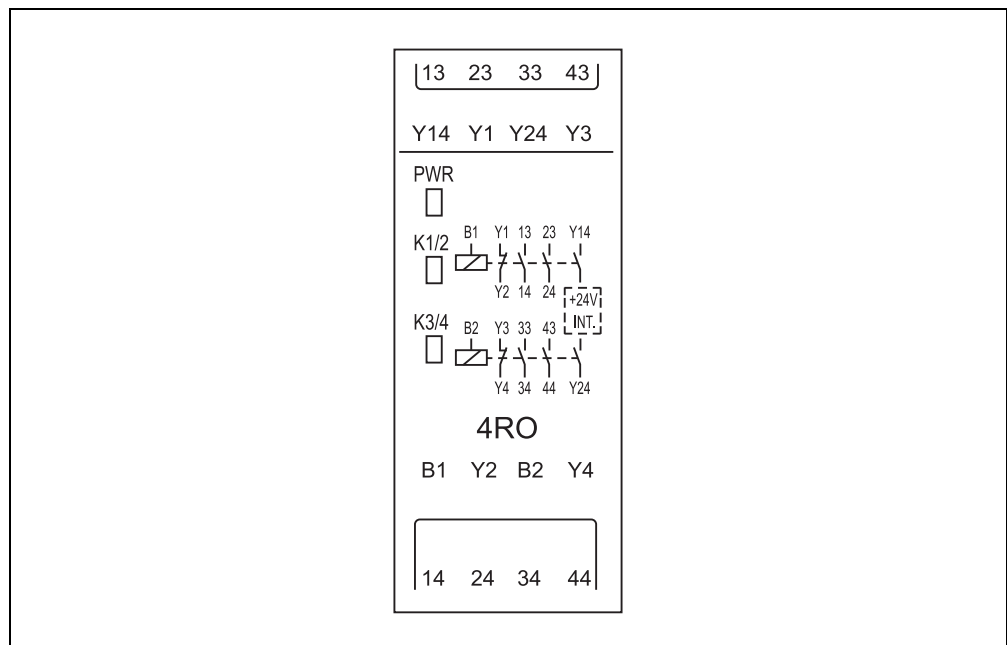

Table 17:
WS0-4RO displays

Display	Meaning
PWR (green)	Supply voltage via safety bus is applied
K1/2 (green)	Relay K1/K2 - safety contacts closed
K3/4 (green)	Relay K3/K4 - safety contacts closed

Table 18:
WS0-4RO terminals

Assignment	Description
B1	Connecting relay K1/K2
B2	Connecting relay K3/K4
13/14 and 23/24	Safety contacts for switch-off circuit outputs K1/K2
33/34 and 43/44	Safety contacts for switch-off circuit outputs K3/K4
Y1/Y2	Feedback EDM K1/K2, NC contact
Y3/Y4	Feedback EDM K3/K4, NC contact
Y14	NO safety contact K1/K2, current-limited (see Chapter 12)
Y24	NO safety contact K3/K4, current-limited (see Chapter 12)

4 Connecting devices

This chapter describes the connection of safety sensors and actuators to the MELSEC-WS safety controller and provides configuration information for the selected functions.

The MELSEC-WS safety controller supports applications up to Performance Level (PL) e (in accordance with EN/ISO 13849-1) and up to Safety Integrity Level SILCL3 (in accordance with IEC 62061).

The degree of safety actually attained depends on the external circuitry, the realization of the wiring, the parameter configuration, the choice of the safety sensors and how they are mounted on the machine. Take and evaluate these using e.g. a failure analysis (FMEA).

For further information that has to be taken into consideration during the electrical installation see Chapter 7.



Loss of the safety function through an incorrect configuration!

- Plan and carry out configuration carefully!

The configuration of safety applications must be carried out with the greatest accuracy and must match the status and the condition of the machine or system to be monitored.

- Check whether the configured safety application monitors the machine or system as planned and whether the safety of a configured application is ensured at all times. This must be ensured in each operating mode and partial application. Document the result of this check!
- In each case, observe the instructions for commissioning and daily checking in the manuals of the protective devices integrated into the safety application!
- Note the warnings and function descriptions of protective devices connected to the MELSEC-WS safety controller! Contact the respective manufacturer of the protective device if in doubt!
- Take into account that the minimum switch-off time of the connected sensors must be greater than the execution time of the logic (see the chapter about the logic editor in the Safety Controller Setting and Monitoring Tool Operating Manual and the logic editor in the Setting and Monitoring Tool) so that it is ensured that the MELSEC-WS safety controller can detect the switching of the sensors. The minimum switch-off time of sensors is usually specified in the technical data of the sensors.

- Note**
- If an odd-numbered test output is used, odd-numbered inputs have to be used. If an even-numbered test output is used, even-numbered inputs have to be used.
 - You have to use the test outputs of the module to which the device to be tested is connected.

**Protect single channel inputs against short circuits and cross circuits!**

If a stuck-at-high error occurs on a single channel input with test pulses that was previously inactive, the logic may see a pulse for this signal. The stuck-at-high first causes the signal to become **Active** (High) and then after the error detection time back to **Inactive** (Low) again. Due to the error detection a pulse may be generated. Therefore single channel signals with test pulses need special attention:

- If the stuck-at-high occurs on a single channel signal input with test pulses that was previously **Active** (High), the logic will see a delayed **Active** (High) to **Inactive** (Low) transition.
- If a single channel input is used and an unexpected pulse or a delayed falling edge at this input may lead to a dangerous situation, the following measures have to be taken:
 - Protected cabling of the related signal (to exclude cross circuits to other signals)
 - No cross circuit detection, i.e. no connection to test output (See the Safety Controller Setting and Monitoring Tool Operating Manual.)

This needs especially to be considered for the following inputs:

- Reset input on the Reset function block
- Restart input on the Restart function block
- Restart input on the Press function blocks (Eccentric Press Contact, Universal Press Contact, N-break, Press Setup, Press Single Stroke, Press Automatic)
- Override input on a Muting function block
- Reset input on a Valve function block
- Reset to zero input and Reload input on a Counter function block

After the configuration you obtain the following documentation in the Setting and Monitoring Tool under “Report”:

- Logic report
- Parts list
- Wiring diagrams

Figure 15:
Example extract of the
documentation in the Setting
and Monitoring Tool

4.1. Installed software components (Tool Version)

Basic components (station)	1.7.0.122
Software component for CPU0 and CPU1 CPU modules	1.7.0.122
Software component for 4RO relay module	1.7.0.122
Software component for GCC1 Network Modules	1.7.0.122
Software component for GETH network modules	1.7.0.122
Software component for XTIO extension module	1.7.0.122
Software component for XTIO extension module	1.7.0.122

4.2. General information

User group	Operator
Application name	CPU1 module
Application description	
Configuration CRC	0xFC91EB8D
Device CRC	0xFC91EB8D
Configuration state	Verified
Device state	Verified
Configuration date	5/20/2016 1:25 PM

0 1 2



Module	Type code	Rev.	Address
CPU1	WS0-CPU1	V 3.xx	0
XTIO	WS0-XTIO	V 3.xx	1
XTDI	WS0-XTDI	V 3.xx	2

4.3. CPU

4.3.1. CPU1 - General information

Type code	Serial number	FW version	Hardware version	Version/Step	Memory usage (UI/Logic)	Address
WS0-CPU1	1530 0003	V 3.02.0	4.00	1.7.0.122 V 3.xx	2.72% / 0.78%	0
WS0-MPL	1524 0064	-	-	1.7.0.122	-	-

4.3.1.1. CRC values

	Project CRC value	Device CRC value
Configuration CRC	0xFC91EB8D	0xFC91EB8D

4.3.2. CPU1 - IO

Tag name	System integrity test based on type key	System integrity test based on serial number	System integrity test based on configuration date
24V 0V A1 A2 CPU1[0] Power supply	-	-	-

4.3.2.1. Wiring diagram

4.1 Safety command devices and electro-mechanical safety switches

4.1.1 Emergency stop pushbuttons (e.g. SICK ES21)

Table 19:
Connection of emergency stop pushbuttons

Electrical connection: Example from Setting and Monitoring Tool with WS0-XTIO		
Single-channel, connected to 24 V		Contact between 24 V and I1
Single-channel, connected to test output		Contact between X2 and I2
Dual-channel, connected to 24 V		Channel 1: Contact between 24 V and I3 Channel 2: Contact between 24 V and I4
Dual-channel, connected to test output		Channel 1: Contact between X1 and I5 Channel 2: Contact between X2 and I6

The dual-channel emergency stop pushbuttons preconfigured in the Setting and Monitoring Tool have equivalent switching contacts. Corresponding elements for implementing dual-channel complementary switching contacts are available in the element window under the group named “Potential-free contacts and restart”.

Table 20:
Functions of emergency stop pushbuttons

Function	Notes
Testing	Possible
Series connection/ cascading	If emergency stop pushbuttons are connected in series, the max. line resistance shall not exceed 100 Ω (see Chapter 12).
Discrepancy times	See Setting and Monitoring Tool.

Note Further information is available in the manual for the emergency stop pushbutton, SICK ES21 or in the manuals for devices used.

4.1.2 Electro-mechanical safety switches with and without interlock

Note The contact symbols in this chapter show the switching status while the door is closed.

Table 21:
Connection of electro-
mechanical safety switches













Electrical connection: Example from Setting and Monitoring Tool with WS0-XTIO		
Single-channel, connected to 24 V	24V  I1 	Contact between 24 V and I1
Single-channel, connected to test output	X2  I2 	Contact between X2 and I2
Dual-channel, connected to 24 V	24V  I3  24V  I4 	Channel 1: Contact between 24 V and I3 Channel 2: Contact between 24 V and I4
Dual-channel, connected to test output	X1  I5  X2  I6 	Channel 1: Contact between X1 and I5 Channel 2: Contact between X2 and I6

Table 22:
Connection of interlocks





















Electrical connection: Example from Setting and Monitoring Tool with WS0-XTIO		
Single-channel, connected to 24 V	24V  I1   Q1 	Contact between 24 V and I1 Coil at Q1
Single-channel, connected to test output	X1  I1   Q1 	Contact between X1 and I1 Coil at Q1
Dual-channel, connected to 24 V	24V  I1  24V  I2   Q1 	Channel 1: Contact between 24 V and I1 Channel 2: Contact between 24 V and I2 Coil at Q1
Dual-channel, connected to test output	X1  I1  X2  I2   Q1 	Channel 1: Contact between X1 and I1 Channel 2: Contact between X2 and I2 Coil at Q1

Table 23:
Functions of electro-
mechanical safety switches
and interlocks

Function	Notes
Testing	Possible
Series connection/ cascading	If safety switches are connected in series, the max. line resistance shall not exceed 100 Ω (see Chapter 12).
Discrepancy times	See Setting and Monitoring Tool.

Note Further information is available in the manuals of the electro-mechanical safety switches or in the manuals for devices used.

4.1.3 Enabling switch (e.g. SICK E100)

Table 24:
Connection of enabling
switches

Electrical connection: Example from Setting and Monitoring Tool with WS0-XTIO		
2 positions, connected to 24 V		Channel 1: Contact E31 between 24 V and I1 Channel 2: Contact E41 between 24 V and I2
2 positions, connected to test output		Channel 1: Contact E31 between X1 and I3 Channel 2: Contact E41 between X2 and I4
3 positions, connected to 24 V		Channel 1: Contact E13 between 24 V and I5 Channel 2: Contact E23 between 24 V and I6 Channel 3: Contact E31 between 24 V and I7 Channel 4: Contact E41 between 24 V and I8
3 positions, connected to test output		Channel 1: Contact E13 between 24 V and I1 Channel 2: Contact E23 between 24 V and I2 Channel 3: Contact E31 between X1 and I3 Channel 4: Contact E41 between X2 and I4

Table 25:
Functions of enabling
switches

Function	Notes
Testing	Possible
Series connection	Not possible
Discrepancy times	See Setting and Monitoring Tool.

Note Further information is available in the manual of the enabling switch, SICK E100 or in the manuals of devices used.

4.1.4 Two-hand control

Note The contact symbols in this chapter show the switching status while both two-hand buttons are not pressed.

Table 26:
Connection of two-hand control

Electrical connection: Example from Setting and Monitoring Tool with WS0-XTIO				
Type IIIA connected to 24 V		Channel 1: Contact between 24 V and I1 Channel 2: Contact between 24 V and I2		
Type IIIC connected to 24 V		Channel 1: Left side NO contact between 24 V and I1 Channel 2: Left side NC contact between 24 V and I2 Channel 3: Right side NO contact between 24 V and I3 Channel 4: Right side NC contact between 24 V and I4		

Type IIIA

At Type IIIA two equivalent inputs (NO contacts of the two two-hand buttons) are monitored.

A valid input signal is only generated if the ON state (High level) exists at both inputs within a period of 0.5 s (synchronous change, both two-hand buttons pressed) and if both were in the OFF state (Low level) beforehand.

Table 27:
Functions with two-hand control unit type IIIA

Function	Notes
Tested	Possible
Series connection/ cascading	Not possible
Discrepancy time	Fixed Value: 500 ms See Two-hand control type IIIA function block in the logic in the CPU module with which these inputs are to be evaluated.

Type IIIC

At Type IIIC two pairs of antivalent inputs (NO/NC contact pairs of the two two-hand buttons) are monitored.

A valid input signal is only generated if the ON state (High/Low level) exists at both inputs within a period of 0.5 s (synchronous change, both two-hand buttons pressed) and if both were in the OFF state (Low/High level) beforehand.

Table 28:
Functions with two-hand control unit type IIIC

Function	Notes
Tested	Possible
Series connection/ cascading	Not possible
Discrepancy time	Possible: 0-500 ms See Two-hand control type IIIC function block in the logic in the CPU module with which these inputs are to be evaluated.
Synchronization time	Fixed Value: 500 ms See Two-hand control type IIIC function block in the logic in the CPU module with which these inputs are to be evaluated.

Note Further information is available in the manual of the two-hand control.

4.1.5 Safety mats and bumpers

Note The contact symbols in this chapter show the switching status while the safety mat or bumper is not pressed.

Table 29:
Connection of safety mats

Electrical connection: Example from Setting and Monitoring Tool with WS0-XTIO		
Pressure-sensitive short-circuiting switching mats in 4-wire technology, connected to test output		Channel 1: Contact between X1 and I1 Channel 2: Contact between X2 and I2

Table 30:
Function of safety mats

Function	Notes
Parallel connection	Possible



Ensure that the switch off condition is sufficient!

The duration of the switch off condition of safety mats and bumpers must be at least as long as the greatest value for the “test period” of both used test outputs to ensure that the switch off condition is detected and that no sequence error occurs.

Note Further information is available in the manual of the safety mats.

4.1.6 User mode switches

Table 31:
Connection of user mode switches

Electrical connection: Example from Setting and Monitoring Tool with WS0-XTIO		
Mode switch (1 of 2) connected to 24 V		Channel 1: Contact between 24 V and I1 Channel 2: Contact between 24 V and I2
Mode switch (1 of 2) connected to test output		Channel 1: Contact between X1 and I1 Channel 2: Contact between X1 and I3

Table 32:
Function of user mode switches

Function	Notes
Testing	Possible

- Note**
- User mode switches without test pulses allow 2 to 8 operating modes; user mode switches with test pulses allow 2 to 4 operating modes.
 - When wiring the tested user mode switches it should be noted that odd-numbered inputs (I1, I3, I5, I7) have to be used if an odd-numbered test output (X1, X3, X5, X7) is used, and even-numbered inputs (I2, I4, I6, I8) have to be used if an even-numbered test output (X2, X4, X6, X8) is used.
 - Further information is available in the manual of the user mode switch.

4.1.7 Potential-free contacts

The Setting and Monitoring Tool makes a series of potential-free contacts available for “free” configuration of contact elements. This allows different NC-/NO-contact combinations with and without testing to be implemented. In addition elements are available for the start and stop button, reset button and external device monitoring (EDM).

Table 33:
Functions of potential-free contacts

Function	Notes
Testing	Possible
Series connection	Possible
Discrepancy time	See Setting and Monitoring Tool.

4.2 Non-contact safety sensors

4.2.1 Magnetic safety switches (e.g. SICK RE)

Note The contact symbols in this chapter show the switching status while the switch is actuated (e.g. while the door is closed).

Magnetic safety switches with equivalent inputs (e.g. SICK RE13, RE27)

Table 34:
Connection of magnetic safety switches with equivalent inputs

Electrical connection: Example from Setting and Monitoring Tool with WS0-XTIO		
Connected to test output		Channel 1: Contact between X1 and I1 Channel 2: Contact between X2 and I2

Magnetic safety switches with complementary inputs (e.g. SICK RE11, RE21, RE31, RE300)

Table 35:
Connection of magnetic safety switches with complementary inputs

Electrical connection: Example from Setting and Monitoring Tool with WS0-XTIO		
Connected to test output		NC contact between X1 and I3 NO contact between X2 and I4

Table 36:
Functions of magnetic safety switches

Function	Notes
Testing	Possible
Series connection/ cascading	Possible; observe the max. line resistance of 100 Ω and the correct setting of the test impulse time
Discrepancy time	Default: 1.5 s. See Setting and Monitoring Tool.

Note Further information is available in the manuals of the SICK magnetic safety switches or in the manuals of devices used.

4.2.2 Inductive safety switches (e.g. SICK IN4000 and IN4000 Direct)

Table 37:
Connection of inductive safety switches

Electrical connection: Example from Setting and Monitoring Tool with WS0-XTIO		
IN4000		Test input TE (IN4000) at X1 Output A (IN4000) at I1
IN4000 Direct (with OSSD)		OSSD1 (IN4000) at I3 OSSD2 (IN4000) at I4

Table 38:
Functions of inductive safety switches

Function	Notes
Testing	Necessary on IN4000
Series connection/ cascading	IN4000 direct cannot be cascaded IN4000 : up to 6 sensors per input Max. off-on delay of the cascade 10 ms (otherwise the test gap will lead to switching off) Observe the max. line resistance of 100 Ω and the correct setting of the test pulse time

Note Further information is available in the manuals of the SICK inductive safety switches or in the manuals of devices used.

4.2.3 Transponder (e.g. SICK T4000 Compact and T4000 Direct)

Table 39:
Connection of transponders



Electrical connection: Example from Setting and Monitoring Tool with WS0-XTIO		
T4000 Compact (connected to 24 V)		24 V at +LA, I1 at LA 24 V at +LB, I2 at LB
T4000 Compact (connected to test output)		X1 at +LA, I3 at LA X2 at +LB, I4 at LB
T4000 Direct (with OSSD)		24 V at UB (T4000), I5 at OA 24 V at UB (T4000), I6 at OB

Table 40:
Functions of transponders



Function	Notes
Testing	Possible for T4000 Compact Not necessary for T4000 Direct, since self monitored
Series connection/ cascading	T4000 Compact is not cascadable; Take the max. line resistance of 100 Ω into account at the T4000 (see Chapter 12)

Note For further information refer to the manuals of the Transponder SICK T4000 Compact or T4000 Direct or in the manuals of devices used.

4.3 Testable single-beam photoelectric safety switches

4.3.1 Testable Type 2 single-beam photoelectric safety switches

Table 41:
Connection of testable Type
2 single-beam photoelectric
safety switches

Electrical connection: Example from Setting and Monitoring Tool with WS0-XTIO		
SICK Wx12/18/24/27, Vx18		Test input TE (transmitter) at X1 Output Q (receiver) at I1
SICK L21, L27/L28		Test input TE (transmitter) at X2 Output Q (receiver) at I2

Note Use protected or separate cabling for the test output of the module (X1...X8) to the test input of the transmitter and for the output of the receiver to the safe input of the module (I1...I8). Otherwise a cross circuit between these signals can inhibit the error detection by this test.

Table 42:
Functions of testable Type 2
single-beam photoelectric
safety switches

Function	Notes
Testing	Possible
Series connection/ cascading	<p>SICK Wx12/18/24/27, Vx18:</p> <ul style="list-style-type: none"> max. 2 pairs per input can be cascaded with test gap = 4 ms (standard element) max. 5 pairs per input can be cascaded with test gap = 12 ms (customized element required) <p>SICK L21:</p> <ul style="list-style-type: none"> max. 10 pairs per input can be cascaded with test gap = 4 ms (standard element) max. 25 pairs per input can be cascaded with test gap = 8 ms (customized element required) <p>SICK L27/L28:</p> <ul style="list-style-type: none"> max. 7 pairs per input can be cascaded with test gap = 4 ms (standard element) max. 18 pairs per input can be cascaded with test gap = 12 ms (customized element required) <p>Take the max. line resistance of 100 Ω into account.</p>

Note For further information refer to the manual of the testable Type 2 single-beam photoelectric safety switches.

4.3.2 Testable Type 4 single-beam photoelectric safety switches

Table 43:
Connection of testable Type
4 single-beam photoelectric
safety switches

Electrical connection: Example from Setting and Monitoring Tool with WS0-XTIO		
SICK L41		Test input TE (transmitter) at X1 Output Q (receiver) at I1

Note Use protected or separate cabling for the test output of the module (X1...X8) to the test input of the transmitter and for the output of the receiver to the safe input of the module (I1...I8). Otherwise a cross circuit between these signals can inhibit the error detection by this test.

Table 44:
Functions of testable Type 4
single-beam photoelectric
safety switches

Function	Notes
Testing	Necessary
Series connection/ cascading	<p>SICK L41:</p> <ul style="list-style-type: none"> max. 10 pairs per input can be cascaded with test gap = 4 ms (standard element) max. 25 pairs per input can be cascaded with test gap = 8 ms (customized element required) <p>Take the max. line resistance of 100 Ω into account</p>

Note For further information refer to the manual of the testable Type 4 single-beam photoelectric safety switches.

4.3.3 Customized testable single beam photoelectric safety switches

For information on how to create customized elements please see the Safety Controller Setting and Monitoring Tool Operating Manual.

- Note**
- In the Settings dialog for the customized element, select the minimum value for the desired test gap.
 - Regardless of the test gap, the overall off-on-delay of the cascade must be smaller than the Max. off-on delay of the respective test output (as shown in the Setting and Monitoring Tool report) –2 ms. Otherwise the test gap will lead to switching off. For WS0-XTIO or WS0-XTDI module this value is = 12 ms – 2 ms = 10 ms.
 - Use protected or separate cabling for the test output of the module (X1...X8) to the test input of the transmitter and for the output of the receiver to the safe input of the module (I1...I8). Otherwise a cross circuit between these signals can inhibit the error detection by this test.

4.3.4 Information for mounting testable single-beam photoelectric safety switches

- Note** Observe the information for mounting in the manual of the respective sensors and in particular the following points:
- Single-beam photoelectric safety switches may only be used as access protection in accordance with EN/ISO 13855. Usage as finger and hand protection is not permissible.
 - Observe the minimum distance to reflective surfaces.
 - It is imperative that the safety distance between the light beam and hazardous point be observed at access protection.

Figure 16:
Minimum distance “a” to reflective surfaces, correct mounting and alignment

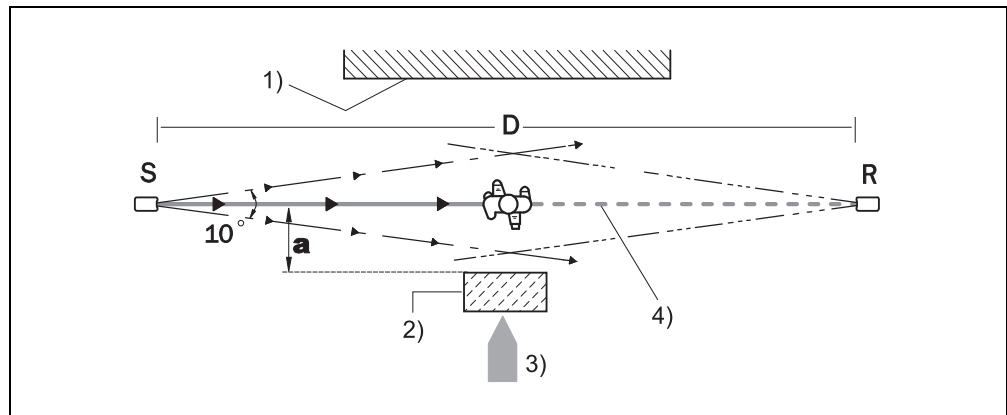

- | | |
|---|--|
| S = Sender | 1) = Limit to hazardous area |
| R = Receiver | 2) = Reflective surface |
| D = Distance between sender and receiver | 3) = Direction of access to hazardous area |
| a = Minimum distance from reflective surfaces | 4) = Optical axis |

Figure 17:
Minimum distance "a" as a factor of the distance "D" for testable single-beam photoelectric safety switches with a field of view of 10° (e.g. SICK Wx12/18/24/27, Vx18)

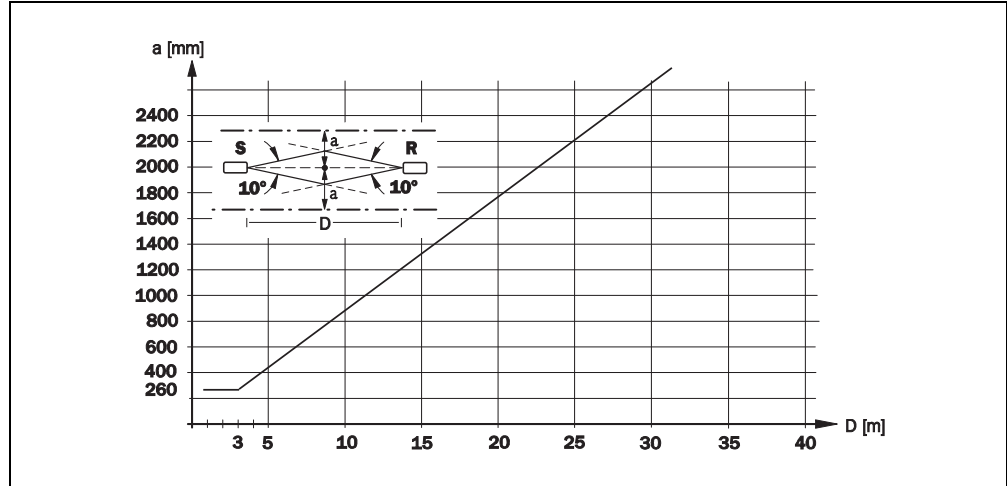

Note Diagrams for SICK L21 and L41 are available in the respective manual.

Avoiding mutual influence at single-beam photoelectric safety switches and between cascades

- If several single-beam photoelectric safety switch pairs are used, the field of view of the sensors has to be observed in order to prevent mutual influence.
- If the senders are only mounted on one side, the light beams may not overlap on the receiver side so that the light beam of one sender does not reach two receivers.
- If the senders and receivers are mounted alternatively, ensure that the light beam of Sender S1 cannot be received by Receiver R3 and that the light beam of Sender S3 cannot be received by Receiver R1.

Figure 18:
Mounting to avoid mutual optical influence

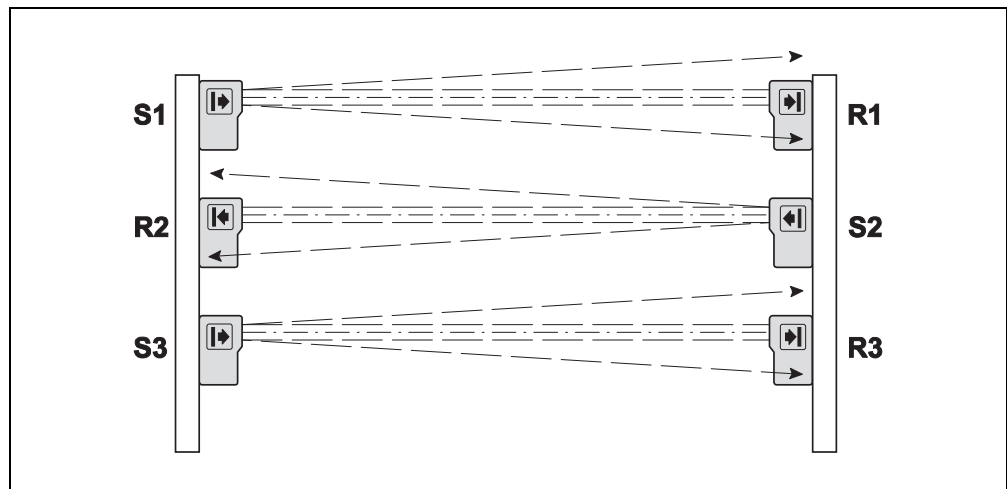

4.4 Electro-sensitive protective equipment (ESPE)

Table 45:
Connection of ESPE

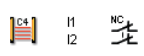
Electrical connection: Example from Setting and Monitoring Tool with WS0-XTIO		
SICK C2000, C4000, M2000, M4000, S300, S3000, V300, MiniTwin	24V 24V	 I1 I2 NC
		OSSD1 (receiver) at I1 OSSD2 (receiver) at I2

Note Further information is available in the manual of the corresponding SICK ESPE or in the manuals of devices used.

4.5 Safety outputs Q1 to Q4



Safety-oriented devices must be suitable for safety related signals!

A function interruption of safe outputs results in a loss of the safety functions so that the risk of serious injury exists.

- Do not connect any loads that exceed the rated values of the outputs Q1 to Q4.
- Connect the GND wires of the power supply to earth so that the devices do not switch on when the output line is applied to frame potential.

4.6 EFI devices

If your MELSEC-WS safety controller contains a WS0-CPU1 or a WS0-CPU3, you can connect intelligent SICK EFI-compatible devices and sensors to your CPU module.

4.6.1 Connection of EFI devices

If shielding is required, for example for EMC reasons, when connecting the EFI devices, use an earth terminal that is placed in the control cabinet near the CPU module for this purpose. Connect this earth terminal with the shielding.

- Note**
- No external termination resistor is required for EFI connections on the CPU module.
 - The CPU module and all connected SICK EFI-compatible devices must have the same 0 V DC of the power supply.
 - The maximum permitted voltage at EFI inputs is ± 30 V (to terminal A2 = 0 V DC)
 - You will find information on connecting SICK EFI-compatible devices incl. pin assignments in the manuals for the corresponding devices.

Cables

SICK offers cables for the connection of SICK EFI-compatible devices. For cables, please contact your local SICK representative (see Section 14.6).

www.sens-control.com

EMC measures

To increase the EMC resistance of the EFI communication, it is recommended to connect the EFI cable shield on one or both sides to functional earth.

Connect this shield to the same DIN mounting rail to which the functional earth (FE) of the MELSEC-WS safety controller is connected in order to minimize interferences on the EFI cable. The connection of the shield to FE should be close to the cable inlet of the control cabinet.

- Note**
- The FE terminal of the MELSEC-WS safety controller is located at the bottom of the housing and connects automatically to the DIN mounting rail when the module is mounted.
 - To avoid further interferences, the functional earth of the SICK sensors (e.g. M4000, S3000) must be connected to the EFI shield as well.
 - If other cables are present within the same cable duct where the EFI cable is routed and these cables emit a high degree of EMC interference (drives or motor related), this can lead to availability problems in the application. In this case, it is recommended to install the EFI cable in a separate duct.

4.7 Flexi Link

4.7.1 Flexi Link overview

Flexi Link allows you to combine up to four Flexi Link stations via EFI for safe data communication. Only modules from WS0-CPU1 or WS0-CPU3 can be used in a Flexi Link system. The connection of WS0-CPU0 modules is not possible.

The process data of each station (inputs and outputs, logic results etc.) can be made available to all other stations in the Flexi Link system. The Teach function allows to temporarily deactivate single stations without impairing the function of the overall system.

Features

- safe connection of up to four Flexi Link stations via EFI.
- connection via EF11 or EF11 and EF12.
- transfer/receive up to 52 bit of information per station (26 bit per EFI channel).
- Each bit can be assigned a global tag name.
- Teaching simulates the presence of temporarily suspended (switched off) stations.
- Any station can be used as access point to address and configure the entire system with the Setting and Monitoring Tool.
- The configuration of the entire Flexi Link system is stored in a single project file.

The Flexi Link system can be connected using only EF11 or using both EF11 and EF12. The overall number of process data bits per station that can be made available to the other stations in the Flexi Link system depends on the connection method:

Connection method	Available process data bits per station
EF11	26
EF11/EF12	52

Table 46:
Available process data bits depending on the connection method

- Note** You can not use Flexi Link and EFI communication at the same time, i.e. it is not possible to connect other SICK EFI-compatible devices on the EF12 connection while EF11 is used for Flexi Link.

4.7.2 System requirements and restrictions for Flexi Link

For Flexi Link the following system requirements must be met as a minimum:

Table 47:
System requirements for
Flexi Link

System component	Version
Hardware	WS0-CPU1 with firmware version V2.01.0 or higher, or WS0-CPU3
Software	WS0-CPU1: Setting and Monitoring Tool version 1.3.0 or higher WS0-CPU3: Setting and Monitoring Tool version 1.7.0 or higher

The Flexi Link system can be connected using only EFI1 or using both EFI1 and EFI2. The overall number of status bits per station that can be made available to the other stations in the Flexi Link system depends on the connection method.

Table 48:
Available status bits
depending on the
connection method

Connection method	Available status bits per station
EFI1	26
EFI1/2	52

- Notes**
- You can not use Flexi Link and EFI communication at the same time, i.e. it is not possible to connect other EFI compatible devices on the EFI2 connection while EFI1 is used for Flexi Link.
 - The process data sent by any station are received almost simultaneously by all other stations. The processing (logic) in the individual stations is, however, not necessarily simultaneous, as the stations are not synchronized.
 - The data on EFI1 and on EFI2 are consistent. The data on EFI1 and EFI2 can, however, be inconsistent for a short time, as they are transferred separately.

4.7.3 Connection of a Flexi Link system



Do not use buffering elements in a Flexi Link system!

It is not allowed to use buffering elements such as e.g. CAN bridges, CAN repeaters or CAN optical light barriers in a Flexi Link system. As a general rule, no components other than Flexi Link stations are allowed. Otherwise the operator of the machine will be in danger.

There are two possibilities for wiring a Flexi Link system:

- connection via EFI1 (26 bits)
- connection via EFI1 and EFI2 (52 bits)

Either way, always the identically named terminals have to be connected (e.g. EFI1 A on station A with EFI1 A on station B etc.).

Figure 19:
Connection of Flexi Link
stations via EF1 and EF2

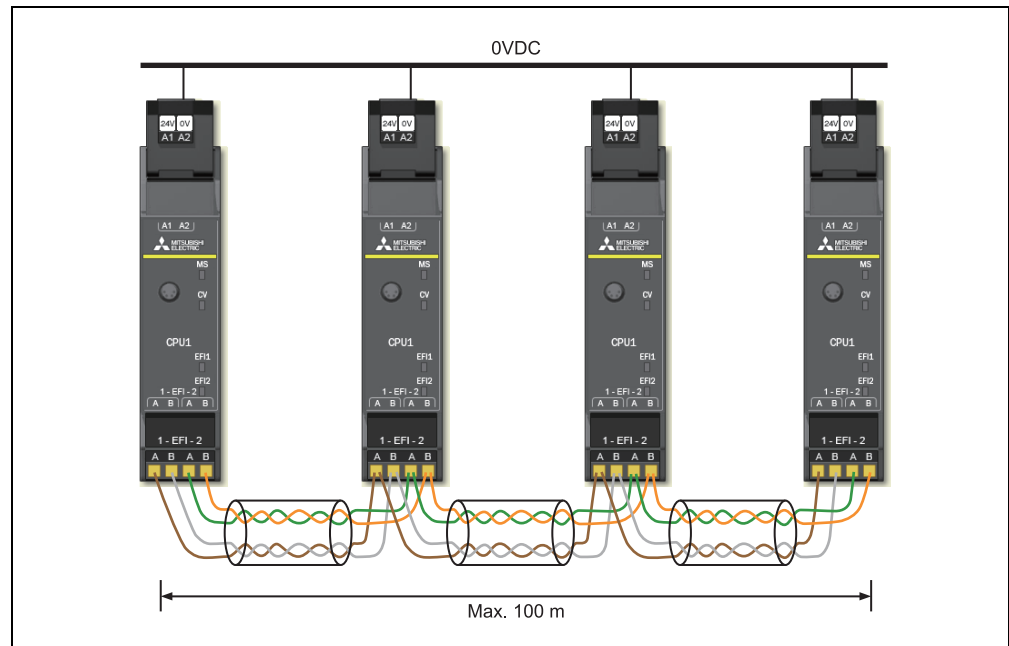

Note No external termination resistor is required for EFI connections on the CPU.

- Stub lines or star-shaped wiring are not permitted.
- The max. permitted overall cable length (all stations) for EF1 and EF2 is 100 m each.
- Unused conductors must be connected to FE on both ends.
- All connected Flexi Link stations must have the same 0 V DC of the power supply (terminal A2 of memory plug).
- The max permitted voltage at EFI inputs is ± 30 V (to terminal A2 = 0 V DC)

Flexi Link cable

The Flexi Link stations can be connected using CAN cables (shielded, twisted pair).

Table 49:
Possible cable lengths and
types for Flexi Link
connections

Cable length	Type
Up to 40 m	2 × 2 × 0.25 mm ² (23 AWG)
Up to 100 m	2 × 2 × 0.34 mm ² (22 AWG)

SICK offers a suitable cable for connection lengths up to 100 m. Please also see Section 13.2. For cables, please contact your local SICK representative (see Section 14.6).

www.sens-control.com

EMC measures

Please observe the notes in section 4.9

Potential equalization

- Always connect the cable screen on both sides to earth potential. Be aware that the earth potential may differ on the earth connections. If this is the case, you must install an additional potential equalization. Follow the relevant standards and regulations.

4.8 Flexi Line

4.8.1 Flexi Line overview

Flexi Line enables you to reliably network up to 32 MELSEC-WS stations. Only WS0-CPU3 modules can be used in a Flexi Line system. The connection of all the other CPU modules (WS0-CPU0, WS0-CPU1) is not possible.

A uniform process image is defined for the entire Flexi Line system. Each byte of this process image is either global, i.e. in the entire system, or local, i.e. only for the related station and its neighboring stations. Each Flexi Line station communicates with its neighboring stations via this process image. The topology permits communication without addressing.

Features

- Reliable connection of up to 32 MELSEC-WS stations via the Flexi Line interface
- Topology without addressing: In case of a change in the order of the stations, it is sufficient to confirm the new arrangement using a Teach pushbutton.
- The EFI interface remains available without limitation:
 - It is possible to connect EFI-compatible sensors.
 - It is possible to connect a Flexi Link system.
- A global process image is defined for all stations.
- Within the process image, global or local bytes can be defined.
- The process image can contain up to 12 bytes or 96 bits.
- The maximum cable length between 2 stations is 1000 meters. The possible total length of a system with 32 stations is therefore 31 kilometers.
- The overall system has a fixed update rate. This rate is dependent on the maximum length of cable between two stations and the size of the process image.

Table 50:
Update rate for a Flexi Line system as a function of the maximum length of cable and the size of the process image

Max. cable length	32 bits	64 bits	96 bits
125 m	2 ms	2 ms	4 ms
250 m	2 ms	4 ms	8 ms
500 m	4 ms	8 ms	12 ms
1000 m	8 ms	12 ms	20 ms

4.8.2 Connection of a Flexi Line system



Do not use buffering elements in a Flexi Line system!

It is not allowed to use buffering elements such as e.g. CAN bridges, CAN repeaters or CAN optical light barriers in a Flexi Line system. As a general rule, no components other than Flexi Line stations are allowed. Otherwise the operator of the machine will be in danger.

The stations in a Flexi Line system are connected together as follows:

- Connect the **Next** connection of each station with the **Prev** connection of the next station
- Connect together the identically labeled terminals, that is **A** to **A** and **B** to **B**.

Figure 20:
Connection of a Flexi Line system

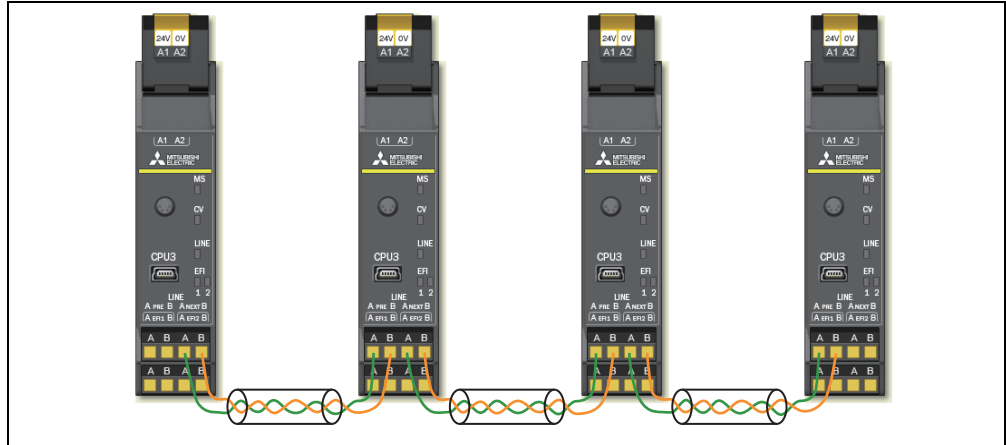

- Notes**
- An external terminator is not required for the Flexi Line connections on the CPU module.
 - Stub lines or star-shaped wiring are not permitted.
 - Unused conductors must be connected to FE on both ends.
 - The max permitted voltage at Flexi Line inputs is $\pm 30V$ (to terminal A2=0VDC).

Flexi Line cable

The Flexi Line stations can be connected using CAN cables (shielded, twisted pair).

Table 51:
Possible cable lengths and types for Flexi Line connections

Cable length	Type
Up to 125 m	2 × 0.34 mm ² (22 AWG)
Up to 1000 m	2 × 0.75 mm ² (18 AWG)

For recommended cables, see Section 13.2.

EMC measures

Please observe the notes in section 4.9.

Equipotential bonding

- Always connect the cable screen on both sides to earth potential. If this is not possible, then earth the side that is connected to the PRE terminals.
- Be aware that the earth potential may differ on the earth connections. If this is the case, you must install an additional equipotential bonding. Follow the relevant standards and regulations.

4.9 EMC measures for Flexi Link and Flexi Line

Flexi Link or Flexi Line cables are used to transmit communication signals. Electromagnetic influences may disturb the signal transfer and interrupt the communication. In order to minimize electromagnetic interference, the following measures are required:

- Connect all inactive metallic parts (control cabinet doors and housing, DIN mounting rails etc.) to the same reference potential.
- Connect the reference potential to the protective earth conductor.
- Connect the protective earth conductor to the external earth potential.
- Connect both ends of the shield of the shielded cables to the reference potential directly at the entrance to the system (control cabinet, frame, DIN mounting rail).
- Connect the cable shield **again** to the reference potential as close as possible to the CPU module (e.g. on the mounting rail) using suitable cable clamps. The cable clamps must completely enclose the cable shield.

Figure 21:
Connection of the cable

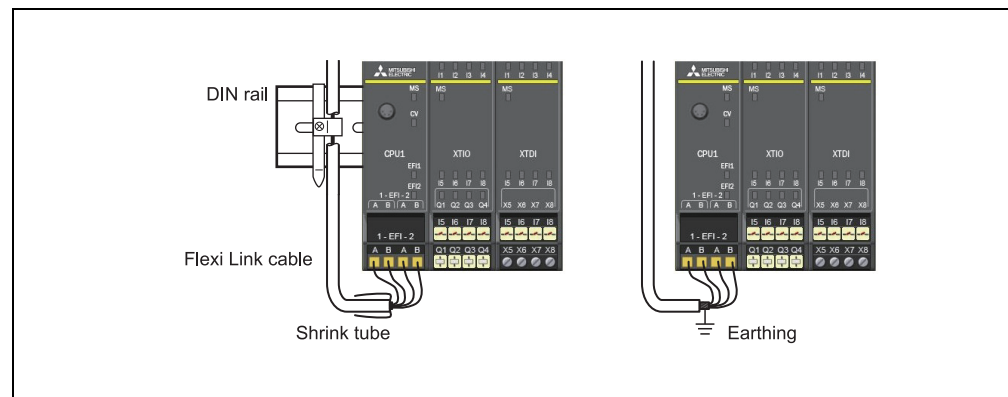

- Keep the stripped cable ends as short as possible.
- Isolate the screening braiding end e.g. with a suitable shrink tube.

- Note**
- All connections must be made electrically well conducting with low impedance.
 - Stub lines or star-shaped EFI wiring are not permitted.
 - Load cables (e.g. for frequency changers, electronic speed controllers, contactors, brakes etc.) and small-signal cables (e.g. measuring lines, analog sensors, field bus lines etc.) must be laid separately and with low inductive coupling.

5 Special functions

5.1 Enhanced Function Interface - EFI

The WS0-CPU1 and WS0-CPU3 CPU modules have 2 EFI interfaces each. This section describes the properties, the functions and the benefits of these interfaces.

The general EFI function description and the possibilities for combining SICK products with regard to EFI are available in the corresponding manuals of SICK products.

5.1.1 Definition

An EFI interface is a safe communication interface between SICK devices. With it information from the sensor equipment can be read out, as well as commands transferred to the sensor equipment.

5.1.2 Properties

- Up to 4 SICK devices are possible per EFI line, in as far as the SICK EFI-compatible devices support this number.
- Connection of the devices using a 2-wire cable
- Various device combination possibilities
 - Sensor with sensor within the same product family
 - Sensor with safety controllers and network modules
 - Connection of up to four WS0-CPU1 or WS0-CPU3 modules in a Flexi Link system (see Section 4.7).
- Transferring of status information (process data) between SICK devices using an EFI interface
- Transferring the configuration from the Setting and Monitoring Tool to the SICK EFI-compatible devices
- Uploading the configuration from the SICK EFI-compatible devices to the Setting and Monitoring Tool
- Activation/utilization of sensor functions

5.1.3 Functions

In addition to the product-specific functions of the respective SICK EFI-compatible devices the following functions are available:

General functions

- **Status information (process data)** of the SICK EFI-compatible devices are available in the MELSEC-WS safety controller and at the sensor
- **Diagnostics information** of all the SICK EFI-compatible devices is available in the controller
- Transfer of configuration information

Special functions

- Simultaneous protective field evaluation
- Protective field switching
- Function changeover
- Operating mode selection
- Signal routing
- Decentralized diagnostics information via Ethernet
- Information on the location of the protective field interruption at host-guest applications
- Evaluation of signals and forwarding of the results

5.1.4 Benefits

- **Reduction of the installation work** (only 2 wires) when signals from several sensors are used
- **Reduction of the required material** through possibility of saving function blocks and I/Os
- **High availability** through provision of the diagnostics information with high information contents for rapid and correct handling options

5.2 Muting

Muting is the automatic temporary bypassing of safety-oriented functions of the control system or of the safety device. Muting is used when certain objects, such as pallets with material, may be moved into the hazardous area. During this transportation through electro-sensitive protective equipment (ESPE), such as a safety light curtain, the muting function inhibits monitoring by the ESPE.

Observe the information in the Safety Controller Setting and Monitoring Tool Operating Manual for the further procedure.

6 Mounting/Dismantling

This chapter describes the mounting of the modules of the MELSEC-WS safety controller.

6.1 Steps for mounting the modules



The MELSEC-WS safety controller must be mounted in a control cabinet with at least IP 54 enclosure rating!

- In a MELSEC-WS safety controller, the WS0-CPU0, WS0-CPU1 or WS0-CPU3 is positioned at the far left.
- The two optional network modules follow directly to the right of the CPU module.
- Connect further MELSEC-WS safety I/O modules (e.g. WS0-XTIO or WS0-XTDI) on the right side of the network modules or on the right side of the CPU module, if no network module is used. The I/O modules can be mounted in any order.
- Connect an additional safety relay output module (WS0-4RO) on the far right of the entire MELSEC-WS safety controller.
- The modules are located in a 22.5 mm wide modular system for 35 mm DIN mounting rails to IEC/EN 60715.
- The modules are connected to each other via the FLEXBUS+ plug connection integrated in the housing. Take into account that, when replacing a module, the MELSEC-WS modules have to be pushed approx. 10 mm apart before the corresponding module can be removed from the DIN mounting rail.
- Mount the modules in accordance with EN 50274.
- Ensure that suitable ESD protective measures are taken during mounting. Otherwise the FLEXBUS+ backplane bus may be damaged.
- Take suitable measures to ensure that foreign matter does not enter the connector openings, in particular that of the memory plug.

Figure 22:
Mounting the module onto
the DIN mounting rail

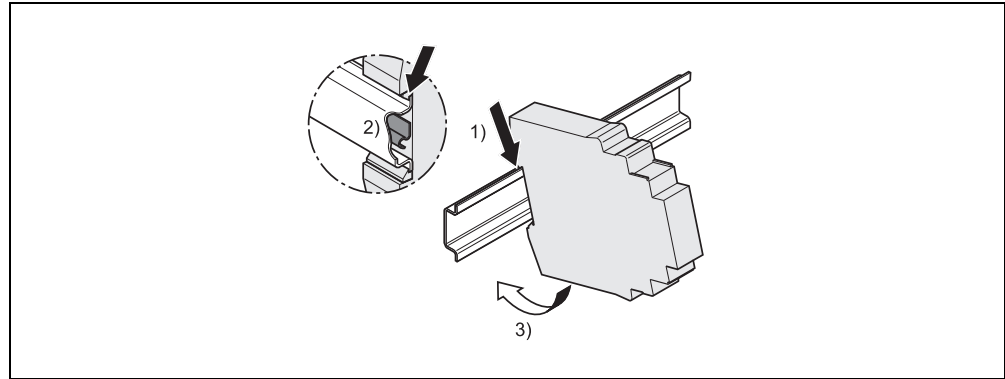

- Make sure that the voltage supply of the MELSEC-WS safety controller is switched off.
- Hang the device onto the DIN mounting rail (1)).
- Ensure that the earthing spring contact is positioned correctly (2)). The earthing spring contact of the module must contact the DIN mounting rail securely to allow electrical conductivity.
- Snap the module onto the DIN mounting rail by pressing it lightly in the direction of the arrow (3)).

Figure 23:
Installing end clips

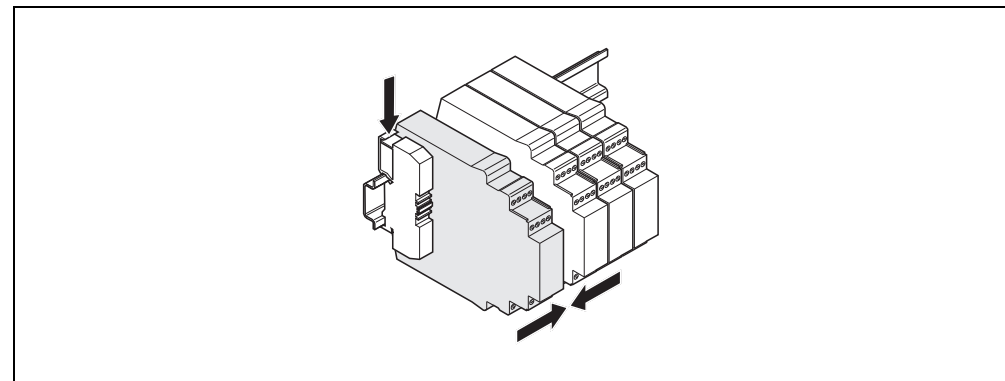

- If there are several modules, slide the modules together individually in the direction of the arrow until the side plug connection latches in.
- Install end clips on the left and right.

The following steps are necessary after mounting:

- completing the electrical connections
- configuration (See the Safety Controller Setting and Monitoring Tool Operating Manual.)
- checking the installation

6.2 Steps for dismantling the modules

Figure 24:
Removing the plug-in terminals

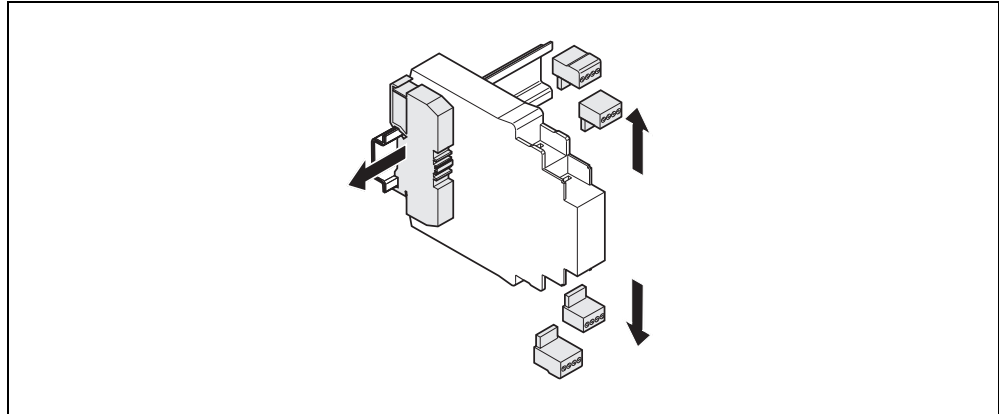

- Remove plug-in terminals with the wiring and the end clips.

Figure 25:
Disconnecting the plug connections

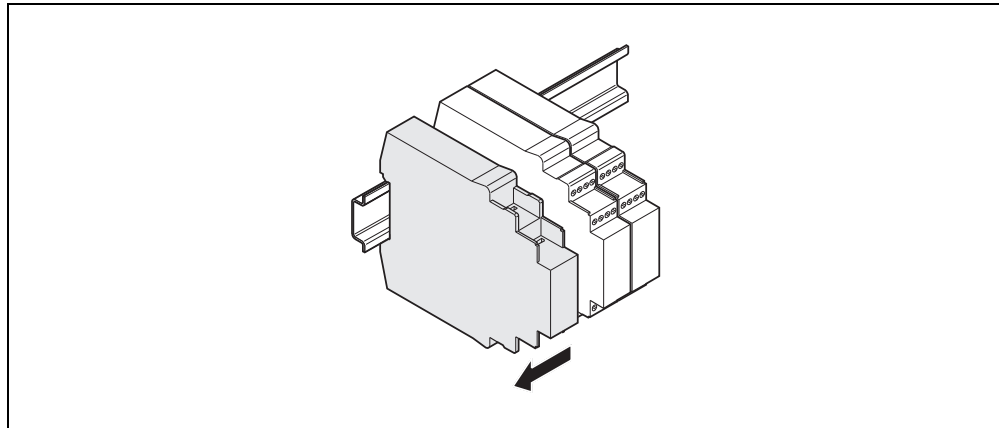

- If there are several modules, slide the modules away from each other individually in the direction of the arrow until the side plug connection is separated.

Figure 26:
Removing modules from the DIN mounting rail

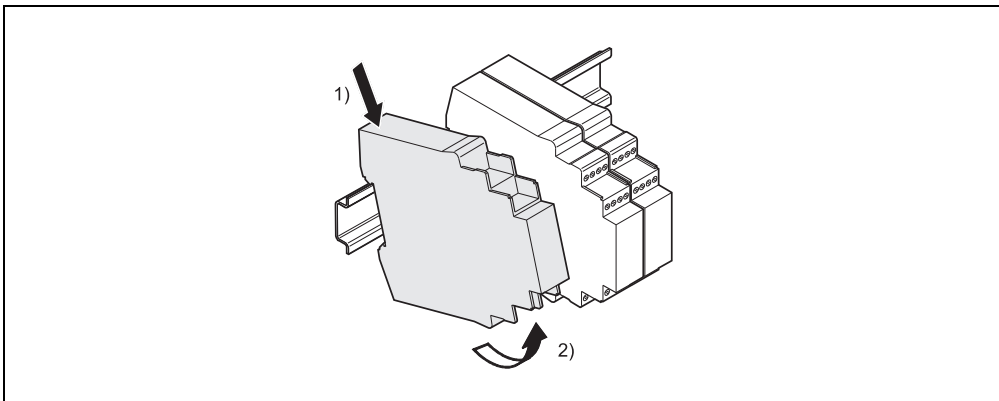

- Press the module downwards at the rear (1)) and remove it from the DIN mounting rail in the direction of the arrow while keeping it pressed down (2)).

7 Electrical installation

7.1 Electrical installation requirements

Note This chapter deals with the electrical installation of the MELSEC-WS safety controller in the control cabinet. You will find additional information on the electrical connection of other devices to the MELSEC-WS safety controller in the section on the respective device in Chapter 4.



Switch off the entire machine/system!

The system could start up unexpectedly while you are connecting the devices.

Observe the relevant safety standards!

All safety related parts of the installation (cabling, connected sensors and actuators, configuration settings, EDM) must be according to the relevant safety standards (e.g. IEC 62061 or ISO/EN 13849-1). This may mean that safety related signals need to be redundant or that single channel signals need protected wiring or short circuit detection by using test outputs and/or periodical function tests.

- Take into account that short circuits between test outputs and the corresponding input cannot be detected.
- Consider if protected or separate cabling is required for these signals.

- Note**
- The MELSEC-WS safety controller fulfills the EMC requirements in accordance with the basic specification IEC 61000-6-2 for industrial use.
 - Mitsubishi industrial safety devices are designed for local DC supply applications only. If the device is used in power supply networks, e.g. according to IEC 61326-3-1, additional protective measures have to be taken.
 - Machines where safety devices are used must be installed and designed according to the Lightning Protection Zone (LPZ) according to IEC 62305-1. Required immunity levels can be achieved through the use of external protective devices. The installed surge protective devices (SPD) should meet the requirements according to IEC 61643-11.
 - The installation must prevent common mode disturbances according to IEC 61000-4-16 in the frequency range from 0 Hz to 150 kHz.
 - To ensure full electromagnetic compatibility (EMC), the mounting rail has to be connected to functional earth (FE).
 - The MELSEC-WS safety controller must be mounted in a control cabinet with at least IP 54 enclosure rating.
 - Electrical installation in accordance with IEC 60204-1
 - The voltage supply of the devices must be capable of buffering brief mains voltage failures of 20 ms as specified in IEC 60204-1.
 - The voltage supply as well as all signals connected have to fulfill the regulations for extra-low voltages with safe separation (SELV, PELV) in accordance with IEC 60664 and EN 50178 (equipment of electrical power installation with electronic devices).
 - You must connect all modules of the MELSEC-WS safety controller, the connected protective devices (e.g. the EFI devices) as well as the voltage supply/ies with the same 0 V DC (GND). The GND of the RS-232 interface is connected internally to the GND of the supply of the CPU module (A2).
 - If the RS-232 interface at the CPU module is used as an alternative to a network module, the maximum permissible cable length is 3 m.

- Avoid ground loops between the GND of the RS-232 interface and the connection A2 of the CPU module, e.g. by using optocouplers.
- Depending on the external loads, especially for inductive loads, additional external protective elements, e.g. varistors or RC elements may be necessary in order to protect the outputs. For operating limits see Chapter 12. Take into account that the response times may increase, depending on the type of protective element.
- If a module is replaced the correct terminal assignment has to be guaranteed, for example by labelling or suitable cable routing.
- If standing behind the protective devices (e.g. safety light curtain) is possible, mount the reset button so that it cannot be actuated by a person located in the hazardous area. When operating the control device of the reset button, the operator must have full visual command of the hazardous area.
- Between the supply circuit and output circuit, and between the input circuit and output circuit in the WS0-4RO module are isolated. On the other hand, those in the safety I/O module are not isolated.
- For wire strip length, follow the specifications of the wire ferrule used. Use a crimping tool to crimp a wire ferrule onto a stranded wire.
- When wiring terminals, use the wire ferrules and the crimping tool listed in the table below. If not, depending on the crimp shape or the material of the wire ferrule used, it can be stuck in the tool and cannot be removed.

Product		Model	Applicable wire size	Wire strip length	Applicable module		Contact
					WS0-CPU0 WS0-CPU1 WS0-CPU3 WS0-XTIO WS0-XTDI	WS0-4RO	
Wire ferrule	Insulated	AI0.34-10TQ	0.34mm ²	12mm	○	–	PHOENIX CONTACT GmbH & Co. KG www.phoenixcontact.com
		AI0.5-10WH	0.5mm ²	13mm			
		AI0.75-10GY	0.75mm ²	13mm			
		AI1-10RD	1.0mm ²	13mm			
		AI1.5-10BK	1.5mm ²	13mm			
		AI0.34-8TQ	0.34mm ²	10mm	○	○	
		AI0.5-8WH	0.5mm ²	11mm			
		AI0.75-8GY	0.75mm ²	11mm			
		AI1-8RD	1.0mm ²	11mm			
		AI1.5-8BK	1.5mm ²	11mm			
	Non-insulated	A0.5-10	0.5mm ²	10mm	○	–	
		A0.75-10	0.75mm ²	10mm			
		A1-10	1.0mm ²	10mm			
		A1.5-10	1.5mm ²	10mm			
		A0.5-8	0.5mm ²	8mm	○	○	
		A0.75-8	0.75mm ²	8mm			
	A1-8	1.0mm ²	8mm				
Crimping tool		CRIMPFOX 6	–		○	○	

- Cable termination method

Strip off the sheath of a cable end and insert the stripped part into a wire ferrule. (For the wire strip length, follow the specifications of the wire ferrule used.) A wire that is stripped too long can cause an electric shock or a short circuit between adjacent terminals because the current-carrying part is exposed at the front side of a terminal block. A wire that is stripped too short can cause a poor contact to the spring clamp terminal part of a terminal block.

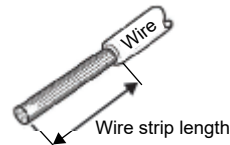

- Use a wire ferrule that is appropriate to the size of the wire used.
- Use an appropriate crimping tool.
- Insert the stripped wire so that it extends out (approximately 0 to 0.5 mm) from the metal sleeve part of a wire ferrule.

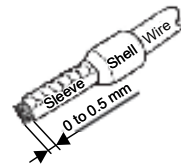

- Visually check the crimped wire ferrule. Do not use a wire ferrule that is not crimped properly or damaged.

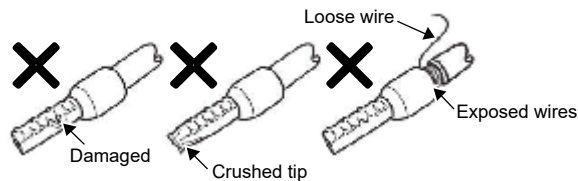

Outer dimensions of crimped wire ferrule

[WS0-4RO]

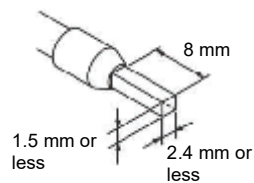

[Other than WS0-4RO]

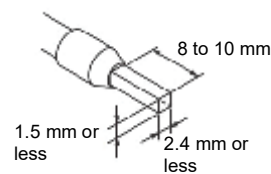

- Connecting cables

Insert the wire onto which a wire ferrule is crimped into a wire insertion opening and push it in. Lightly pull the wire to test it is securely held. If the size of the wire ferrule is inappropriate or the wire is inserted in incorrect orientation, the inserted wire can be stuck or the terminal block is damaged. Ensure that the wire is inserted in the following orientation.

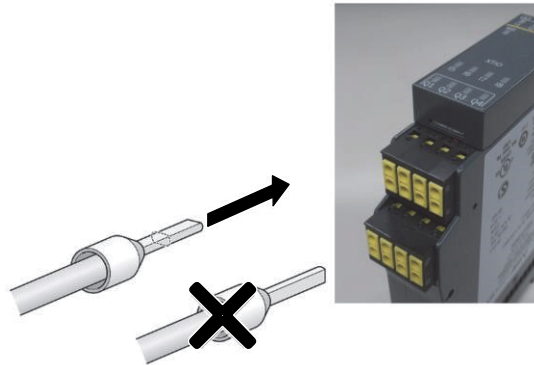

- Removing cables

Push a flathead screwdriver (removal tool) all the way into the opening 1) at the front side of the module, or fit a flathead screwdriver in a slot 2) between wire insertion openings and push it all the way, and pull the cable out. Reference product of removal tool: SZF 0-0.4x2.5 manufactured by PHOENIX CONTACT GmbH & Co. KG

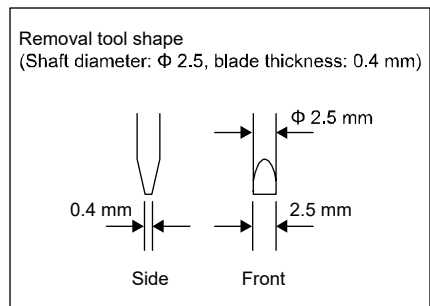
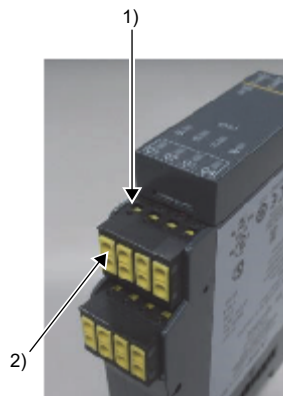

**Limited short-circuit recognition!**

An WS0-XTDI has two test signal generators. One test signal generator is responsible for the odd-numbered test outputs X1, X3, X5 and X7, the other for the even-numbered test outputs X2, X4, X6 and X8.

Short-circuits between test signal generators on MELSEC-WS I/O modules are detected, also between test signal generators on different modules, provided the test gaps are ≤ 4 ms and the test periods are ≥ 200 ms for the relevant test outputs. Short circuits to 24 V DC (stuck at high) at inputs connected to test outputs are detected independently of the test gap time.

Please be aware that at the WS0-XTDI the odd-numbered test outputs X1, X3, X5 and X7 are connected to one common test signal generator and that the even-numbered test outputs X2, X4, X6 and X8 are connected to another common test signal generator. Therefore short circuits between test outputs X1, X3, X5 and X7 cannot be detected. The same applies respectively for test outputs X2, X4, X6 and X8.

Take this into consideration during the wiring (e.g. separate routing, sheathed cables)!

Reverse current at WS0-XTIO / WS0-XTDI inputs in case of ground interruption

In case of an internal or external ground interruption there can be a reverse current from the power supply of the CPU module (memory plug terminal A2) to the safe inputs I1...I8 of WS0-XTIO / WS0-XTDI modules. This must be considered if other inputs are connected in parallel to these inputs, so that this reverse current does not lead to an unintended High level at the parallel connected inputs.

7.2 Internal circuit power supply

Figure 27:
Safety controller power
supply internal circuit

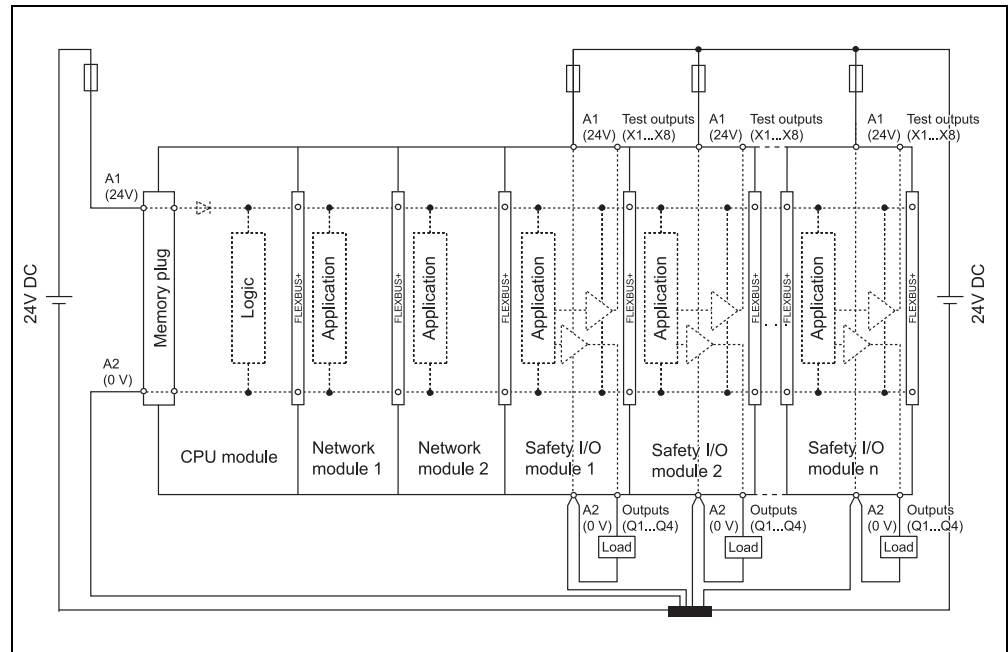

8 Configuration



Check the safety function before commissioning and after every change!

If you change the configuration, you must check the effectiveness of the safety function. Please observe the test notes in the manuals of the connected protective devices.

Note The Setting and Monitoring Tool and the WS0-MPL0 or WS0-MPL1 memory plug are required to configure the MELSEC-WS safety controller.

Configuration and verification of devices that are connected to the safety controller is generally not carried out via the Setting and Monitoring Tool. These devices have their own mechanisms for configuration and verification. One exception are SICK EFI-compatible devices connected to the WS0-CPU1 or WS0-CPU3 (the SICK EFI-compatible devices can be found under “EFI elements” in the elements window). These devices can be configured directly in the Setting and Monitoring Tool by double-clicking the icon, or alternatively configured and verified locally at the device via its RS-232 interface. The SICK configuration and diagnostics software CDS is required for the configuration of the SICK EFI-compatible devices.

- The SICK configuration and diagnostics software CDS included in Setting and Monitoring Tool is the product of SICK. For the CDS, please contact your local SICK representative (see Section 14.6).
www.sens-control.com
- The system configuration of the complete MELSEC-WS safety controller (with exception of the SICK EFI-compatible devices) is stored in the memory plug. This offers the advantage when safety I/O modules or network modules are replaced that the system does not have to be reconfigured.
- The data stored in the memory plug is retained when the voltage supply is interrupted.
- The transfer of configuration information via the EFI interface is possible.

9 Commissioning



Do not commission without a check by qualified safety personnel!

Before initial commissioning of a system using a MELSEC-WS safety controller, it must be checked and released by qualified safety personnel.

Check the hazardous area!

Ensure that no one is located in the hazardous area before commissioning.

- Check the hazardous area and secure it against being entered by people (e.g. set up warning signs, attach blocking ropes or similar). Observe the relevant laws and local regulations.

9.1 Full approval of the application

System commission may only be carried out if full approval was successful. Full approval may only be performed by professionals trained accordingly.

The full approval includes the following items to be checked:

- Check whether all safety related parts of the installation (cabling, connected sensors and actuators, configuration settings) are according to the relevant safety standards (e.g. EN/ISO 13849-1 or IEC 62061).
- Check the devices connected to the safety controller in accordance with the test notes in the accompanying manual.
- Label all connections (connection cables and plugs) at the safety controller clearly and without ambiguity to avoid confusion. Since the MELSEC-WS safety controller has several connections of the same design, ensure that disconnected cables or plugs cannot be connected back unintentionally to the wrong connection.
- Check the signal paths and the correct inclusion in higher-level controllers.
- Check the correct data transfer from and to the MELSEC-WS safety controller.
- Check the logic program of the safety controller.
- Perform a complete validation of the safety functions of the system in each operating mode and an error simulation. Observe the response times of the individual applications in particular.
- Completely document the configuration of the system, the individual devices and the result of the safety check.
- In order to prevent unintentional overwriting of the configuration, activate the write protection of the configuration parameters of the MELSEC-WS safety controller. Modifications are only possible if the write protection has been deactivated.

9.2 Tests before the initial commissioning

A report that provides the configuration can be created with the Setting and Monitoring Tool.

The purpose of the initial commissioning tests is to confirm the safety requirements specified in the national/international rules and regulations, especially in the Machine and Work Equipment Directive (EC Conformity).

- Check the effectiveness of the protective device at the machine, using all the selectable operating modes and functions.
- Ensure that the operating personnel of the machine fitted with the safety controller become instructed by the qualified personnel of the machine owner before beginning work. Arranging the instruction is the responsibility of the machine owner.

10 Diagnostics

10.1 In the event of faults or errors



Cease operation if the cause of the malfunction has not been clearly identified!

Stop the machine if you cannot clearly identify or allocate the error and if you cannot safely remedy the malfunction.

Complete functional test after remedying malfunction!

Carry out a full functional test after a malfunction has been remedied.

10.1.1 ERROR operating states

With certain malfunctions or a faulty configuration, the MELSEC-WS safety controller enters the safe status. The LEDs of the individual modules of the safety controller indicate the corresponding error level.

Depending on the error there are different error levels:

Configuration error

- The system will be in state Configuration required (MS LED ✱ Red (1Hz)).
- Applications in all modules are in operating state “Stop”.
- All safe outputs in the system are switched off.
- All safety process data is set to zero. Typically also not safety related process data is set to zero.

Recoverable error

- Applications in all modules remain in operating state Run (MS LED of the effected modules = ✱ Red/green alternating (1 Hz), MS LED of not effected modules = ● Green).
- If safe outputs on the system are effected, then as a minimum these outputs are switched off.
- If safe inputs are effected, then at least the process data for these safe inputs are set to zero.

Critical fault

- The system will be in state Critical fault (MS LED of the module which detected the critical fault = ✱ Red (2 Hz). MS LED of the modules which are unclear about the error origin = ● Red).
- Applications in all modules are in operating state ‘Stop’.
- All safe outputs in the system are switched off.
- All safety process data is set to zero. Typically also not safety related process data is set to zero.

How to place the device back in operation:



- Rectify the cause of the malfunction in accordance with the display of the MS and CV LEDs.
- In the case of critical faults, switch the voltage supply of the MELSEC-WS safety controller off for at least 3 seconds and back on again.















The MELSEC-WS safety controller may restart when it detects a recoverable error caused by noise. The MELSEC-WS safety controller is ready for operation again if the error cause has been eliminated after the restart. Create an interlock program using a reset button to prevent the MELSEC-WS safety controller from restarting automatically after the safety function is activated and the safety controller turns off the outputs.

10.2 Error displays of the status LEDs, error messages and rectification measures

This section lists and describes the most important error codes, possible causes and potential rectification measures. These error messages can be displayed in the **Diagnostics** view of the Setting and Monitoring Tool if you are connected to the MELSEC-WS safety controller.

- Note**
- For information on how to perform diagnostics see the Safety Controller Setting and Monitoring Tool Operating Manual.
 - Error displays for the individual modules and error elimination are described in the sections on the individual modules, see Sections 3.5 to 3.10.

LED indication on module		Possible error codes	Possible reasons	Possible measures
CPU module (WS0-CPU0, WS0-CPU1 or WS0-CPU3)	Safety I/O module (WS0-XTIO or WS0-XTDI)			
MS =  Red (1 Hz)	All safety I/O modules: MS =  Red (1 Hz) (firmware ≥ V2.00.0) or MS =  Red/green (1 Hz) (firmware V1.xx.0)	CPU module: 0x000E4006, 0x00160005, 0x000F0013	Configuration in memory plug is incompatible because it is for a different CPU module type: <ul style="list-style-type: none"> • Memory plug has been used before in a system with different CPU module type (e.g. WS0-CPU0 instead of WS0-CPU1 or vice versa). • Wrong CPU module type is used in the hardware installation. 	<ul style="list-style-type: none"> • Download a configuration with the same CPU module type as in the hardware installation. • Replace the CPU module in the hardware installation by a module with the same module type as selected in the project file.
		CPU module: 0x00170005, 0x000F0013	Configuration in memory plug is incompatible because it is for a newer firmware version of the CPU module: <ul style="list-style-type: none"> • Memory plug has been configured for an incompatible higher CPU module firmware version (e.g. V1.xx instead of V2.xx). • An older CPU module firmware version is used in the hardware installation. 	<ul style="list-style-type: none"> • Download a configuration with the same or a smaller CPU firmware version (e.g. V1.xx instead of V2.xx). • Replace the CPU module in the hardware installation by a module with an equal or higher firmware version selected in the project file.
		CPU module: 0x000E4013, 0x00274006	Configuration in memory plug is incompatible for at least one safety I/O module: <ul style="list-style-type: none"> • Safety I/O module is missing in the hardware installation. 	<ul style="list-style-type: none"> • Download a configuration with a matching list of safety I/O modules. • Add missing safety I/O module in the hardware installation.
		CPU module: 0x000E0006, 0x0005000D. WS0-XTIO/ WS0-XTDI: 0x4901, 0x4904	Configuration in memory plug is invalid: <ul style="list-style-type: none"> • The last configuration procedure has not been completed successfully, e.g. because the power supply has been turned off before writing to the memory plug has been completed. • Memory plug hardware failure. • The memory plug is empty (out-of-the-box value). 	<ul style="list-style-type: none"> • Download the configuration again and ensure that the power supply at the CPU module is on until the download procedure has been completed. • Replace the memory plug and download configuration again.

LED indication on module		Possible error codes	Possible reasons	Possible measures
CPU module (WS0-CPU0, WS0-CPU1 or WS0-CPU3)	Safety I/O module (WS0-XTIO or WS0-XTDI)			
MS =  Red (1 Hz) EFI =  Red (1 Hz)	One or more safety I/O modules: MS =  Red (1 Hz) (firmware ≥ V2.00.0) or MS =  Red/green (1 Hz) (firmware V1.xx.0)	CPU module: 0x0014000A	If WS0-CPU1: EFI device address conflict: <ul style="list-style-type: none"> There are at least 2 CPU modules with the same EFI address connected. 	<ul style="list-style-type: none"> Change the EFI device address with Setting and Monitoring Tool, either of the CPU module or of the connected device.
		CPU module: 0x0015000A	If WS0-CPU1 and Flexi Link: Wrong Flexi Link ID: <ul style="list-style-type: none"> EFI1 and EFI2 is swapped in the wiring. There is at least 1 CPU module with a different Flexi Link ID connected. 	<ul style="list-style-type: none"> Check wiring between the Flexi Link stations: EFI1 connected with EFI1, and if applies EFI2 with EFI2. Connect Flexi Link stations with matching Flexi Link IDs. Download configuration to all Flexi Link stations with same Flexi Link IDs.
		CPU module: 0x001F0006, 0x00230006, 0x00234006, 0x001F4006	Configuration in memory plug is incompatible for at least one safety I/O module: <ul style="list-style-type: none"> Wrong type or version of module (whose MS LED is flashing red or red/green). Too many safety I/O modules are connected (whose MS LED is flashing red or red/green). Safety I/O modules are missing (MS LED of all other modules is flashing red or red/green). 	<ul style="list-style-type: none"> Download a configuration with the same module type and the same or a smaller firmware version for all safety I/O modules. Replace the affected safety I/O module in the hardware installation by a module with the same module type and the same or smaller firmware version as selected in the project file.
MS =  Green (1 Hz) CV =  Yellow (1 Hz)	MS =  Green (1 Hz)	--	System is in Stop state (ready to run).	Start application in Setting and Monitoring Tool. For automatic start after power up a verification of the project is necessary with Setting and Monitoring Tool.
MS =  Green (1 Hz) CV =  Yellow	MS =  Green (1 Hz)	--	System is in Stop state (ready to run).	Start application in Setting and Monitoring Tool.
MS =  Green	MS =  Green	--	System is in operation. No error detected.	--
	One or more safety I/O modules : MS =  Red/green (1 Hz) (firmware ≥ V2.00.0) or MS =  Red (1 Hz) (firmware V1.xx.0) and Q1+Q2+Q3+Q4 =  Green (1 Hz)	WS0-XTIO: 0x4804, 0x4806, 0x4807	Module power supply of WS0-XTIO is too low or missing.	Check supply voltage at terminals A1 (24 V) and A2 (0 V) at the WS0-XTIO module, also under worst case load conditions. Error is reset automatically after approx. 8 seconds, if the error reason no longer exists.

LED indication on module		Possible error codes	Possible reasons	Possible measures
CPU module (WS0-CPU0, WS0-CPU1 or WS0-CPU3)	Safety I/O module (WS0-XTIO or WS0-XTDI)			
MS = ● Green	One or more safety I/O modules : MS = ☼ Red/green (1 Hz) (firmware ≥ V2.00.0) or MS = ☼ Red (1 Hz) (firmware V1.xx.0) and Q1 or Q2 or Q3 or Q4 = ☼ Green (1 Hz)	WS0-XTIO: 0x4701, 0x4702, 0x4704, 0x4705.	Short circuit to 24 V or cross circuit in wiring of safe output Q1...Q4 (whose LED is flashing). <ul style="list-style-type: none"> Capacitive load exceeded the allowed maximum value (e.g. by capacitor for spark quenching). Inductive load exceeded the maximum value allowed Internal Hardware failure of WS0-XTIO module Short circuit to 0 V in wiring of safety output Q1...Q4 (whose LED is flashing). Power supply on the XTIO module interrupted briefly 	<ul style="list-style-type: none"> Check wiring of all output. Check capacitive load. Check inductive load. Replace XTIO module. To reset the error all outputs of the effected module have to be turned off from logic of by turning off related input signals, e.g. E-stop. Error reset can take up to 8 seconds. Alternatively power cycle the CPU module.
	One or more safety I/O modules : MS = ☼ Red/green (1 Hz) (firmware ≥ V2.00.0) or MS = ☼ Red (1 Hz) (firmware V1.xx.0) and I1 or I2 or I3 or I4 or I5 or I6 or I7 or I8 = ☼ Green (1 Hz)	WS0-XTIO/ WS0-XTDI: 0x4601	For inputs which are connected to test output: <ul style="list-style-type: none"> Short circuit to 24 V or cross circuit in wiring for tested sensors: <ol style="list-style-type: none"> Short circuit to 24 V or cross circuit in wiring from X1, X2,...or X8 to tactile switch or test input of testable input. Short circuit to 24 V or cross circuit in wiring from tactile switch or output of testable sensor to I1, I2,...or I8. Defect testable sensor. Cable interruption in wiring for safety mat: <ol style="list-style-type: none"> Cable interruption in wiring from X1, X2,...or X8 to safety mat. Cable interruption in wiring from safety mat to I1, I2,...or I8. Defect safety mat. 	<ul style="list-style-type: none"> Check wiring of effected input. Replace testable sensor. To reset the error turn off the effected input (input state Low/Low for equivalent dual channel inputs, Low/High for complementary dual channel inputs) or power cycle the CPU module.

LED indication on module		Possible error codes	Possible reasons	Possible measures
CPU module (WS0-CPU0, WS0-CPU1 or WS0-CPU3)	Safety I/O module (WS0-XTIO or WS0-XTDI)			
MS = ● Green	One or more safety I/O modules : MS = ✨ Red/green (1 Hz) (firmware ≥ V2.00.0) or MS = ✨ Red (1 Hz) (firmware V1.xx.0) and I1+I2 or I3+I4 or I5+I6 or I7+I8 = ‡ Green (1 Hz)	WS0-XTIO/ WS0-XTDI: 0x4429 or 0x442A	Discrepancy error or sequence error at dual channel inputs (whose LEDs are flashing green):*1 <ul style="list-style-type: none"> Cable interruption or short circuit to 0 V at one of both input signals of the input pair. Hardware failure of sensor, e.g. one of both contacts/outputs is permanently closed (High) or opened (Low). Defect sensor (one of both signals does not change to the corresponding state to the other input within the configured discrepancy time. Opening or closing of safety door was too slow so that the 2 contacts switches (e.g. reed contacts) did not switch within the configured discrepancy time. Only one of both inputs has caused the switch off condition and has changed back to the on condition, without the other input having changed at all (sequence error). 	<ul style="list-style-type: none"> Check wiring of effected input and check switching capability of both contacts/outputs of the connected sensor. Check mechanical dependency of both switches. Replace switch/sensor in hardware installation <p>To reset the error the effected input pair has to be Low/Low for equivalent dual channel inputs and Low/High for complementary dual channel inputs.</p>
MS = ● Red	MS = ● Red	CPU module: 0XXXXCXXXX. Safety I/O modules: 0XCXXX (X= any value)	<ul style="list-style-type: none"> Power supply 0 V at WS0-XTIO module missing (firmware V1.xx.0 only). Internal error in safety I/O module. Internal error in CPU module. 	<ul style="list-style-type: none"> Check connection of terminal A2 of WS0-XTIO modules to 0 V of power supply. Check installation for EMC influence (earthing of DIN mounting rail,...). To reset the error power cycle the CPU module. If the error persists, then replace modules.
MS = ● Red	MS = ✨ Red (2 Hz) (with firmware ≥ V2.00.0)	CPU module: 0XXXXCXXXX. Safety I/O modules: 0XCXXX (X= any value)	Internal error in safety I/O module (whose MS LED is flashing).	<ul style="list-style-type: none"> Check installation for EMC influence (earthing of DIN mounting rail,...). To reset the error power cycle the CPU module If the error persists, then replace the module whose MS LED is flashing.
MS = ✨ Red (2 Hz) (with firmware ≥ V2.01.0)	MS = ● Red	CPU module: 0XXXXCXXXX. Safety I/O modules: 0XCXXX (X= any value)	Internal error in CPU module or in the system.	<ul style="list-style-type: none"> Check installation for EMC influence (earthing of DIN mounting rail,...). To reset the error power cycle the CPU module If the error persists, then replace subsequently CPU module and safety I/O modules

LED indication on module		Possible error codes	Possible reasons	Possible measures
CPU module (WS0-CPU0, WS0-CPU1 or WS0-CPU3)	Safety I/O module (WS0-XTIO or WS0-XTDI)			
MS = ● Red or ☼ Red (2 Hz) (with firmware ≥ V2.01.0) or MS = ● Red (firmware V1.xx.0)	MS = ● Red or ☼ Red (2 Hz) (with firmware ≥ V2.00.0) or MS = ● Red (firmware V1.xx.0)	CPU module: 0x0006C002, 0x0007C002, 0x0001C005, 0x0003C006, 0x0005C006, 0x0029C006, 0x0003C013	<ul style="list-style-type: none"> Follow on error for other critical errors. Disturbance of CPU module internal signals due to heavy EMC disturbance. Hardware failure in CPU module or any safety I/O module. 	<ul style="list-style-type: none"> Check the other diagnosis messages for critical faults with almost the same time stamp. To reset the error power cycle the CPU module. If error persists, then replace subsequently CPU module and safety I/O modules.
		CPU module: 0x0001C013, 0x0004C013, 0x0005C013, 0x000CC013	<ul style="list-style-type: none"> FLEXBUS+ communication (backplane communication to I/O modules and to network modules) disturbed due to EMC disturbance. FLEXBUS+ communication (backplane communication to I/O modules and to network modules) disturbed due to critical fault in I/O modules. In this case this is a follow on error and there will be also other critical faults with almost the same time stamp (± 1 s) in the diagnosis history. 	<ul style="list-style-type: none"> To reset the error power cycle the CPU module. Check installation for EMC aspects (FE connection of DIN mounting rail and control cabinet, star wiring of 24 V power supply, local separation of power parts and control parts,...) Check the other diagnosis messages with almost same time stamp.
		CPU module: 0x002AC006	Unequal input data from safety I/O module: ² <ul style="list-style-type: none"> A dual channel input at WS0-XTIO module or WS0-XTDI module has 2 signal dips (High to Low) with a time distance of 2 ms (e.g. test gaps of an OSSD output or bouncing relay contacts). A signal channel input at WS0-XTIO module or WS0-XTDI module changes state in intervals of 4 ms for a duration of 40 ms or more (e.g. proximity switch to a tooth wheel). 	<ul style="list-style-type: none"> To reset the error power cycle the CPU module. Change the configuration by activating the ON-OFF filter and activating the OFF-ON filter for inputs of the effected WS0-XTIO/WS0-XTDI module. Please be aware that this increases the response time for this signal by at least 8 ms.
		WS0-XTIO/ WS0-XTDI: 0xC306 CPU module: 0x0029C006	<ul style="list-style-type: none"> Internal hardware failure of WS0-XTIO or WS0-XTDI module. Follow on error of CPU module: 0x0029C006 	<ul style="list-style-type: none"> To reset the error power cycle the CPU module. Replace WS0-XTDI/WS0-XTIO module in hardware installation.
		WS0-XTIO/ WS0-XTDI: 0xC307 CPU module: 0x0029C006	<ul style="list-style-type: none"> Power supply at terminal A2 (GND) of WS0-XTIO module interrupted. Internal hardware failure of WS0-XTIO or WS0-XTDI module. Follow on error of CPU module: 0x0029C006 	<ul style="list-style-type: none"> Check supply voltage at terminals A1 (24 V) and A2 (0 V) at the WS0-XTIO module, also under worst case load conditions. To reset the error power cycle the CPU module. If the error persists, replace WS0-XTDI/WS0-XTIO module in hardware installation.
		WS0-XTIO: 0xC30A CPU module: 0x0029C006	<ul style="list-style-type: none"> Short circuit to 24V or cross-circuit in wiring of safe output Q1...Q4 (whose LED is flashing). Capacitive load exceeded the allowed maximum value (e.g. by capacitor for spark quenching). Inductive load exceeded the maximum value allowed Internal hardware failure of WS0-XTIO module. Follow on error of CPU module: 0x0029C006 	<ul style="list-style-type: none"> Check wiring of effected output. Check capacitive load. Check inductive load. To reset the error power cycle the CPU module. If the error persists, replace WS0-XTIO module in hardware installation.

LED indication on module		Possible error codes	Possible reasons	Possible measures
CPU module (WS0-CPU0, WS0-CPU1 or WS0-CPU3)	Safety I/O module (WS0-XTIO or WS0-XTDI)			
MS = ● Green	All safety I/O modules: MS = ● Green	CPU module: 0x000A0011	<p>Function block error with dual channel input evaluation (e.g. Emergency stop, Magnetic switch): Discrepancy error at pair 1 of function block:</p> <ul style="list-style-type: none"> Cable interruption or short circuit to 0 V at one of both input signals of the input pair. Hardware failure of sensor, e.g. one of both contacts/outputs is permanently closed (High) or opened (Low). Defect sensor (one of both signals does not change to the corresponding state to the other input within the configured discrepancy time. Opening or closing of safety door was too slow, so that the 2 contacts switches (e.g. reed contacts) did not switch within the configured discrepancy time. 	<ul style="list-style-type: none"> Check the wiring of the effected input and check switching capability of both contacts/outputs of the connected sensor. Check mechanical dependency of both switches. Replace switch/sensor in hardware installation <p>To reset the error the effected input pair has to change within the configured discrepancy time from Low/Low to High/High for equivalent dual channel inputs, from Low/High to High/Low for complementary dual channel inputs.</p>
		CPU module: 0x00100011	<ul style="list-style-type: none"> Function block error (EDM or Valve monitor): Feedback signal did not follow the control signal within the max. feedback delay time. Hardware failure of connected relay/valve or failure in the wiring. Used relay/valve has greater switching delay for monitor contact. 	<ul style="list-style-type: none"> Increase Max. feedback delay time of the function block, if acceptable for the application. Replace relay/valve in the hardware installation.
All LEDs temporarily off and then LED test sequence.	All LEDs temporarily off and then LED test sequence.	CPU module: 0x002D4006	<ul style="list-style-type: none"> Power supply of CPU module had short voltage dip (to almost 0 V). Power supply of CPU module had a voltage drop (approx. down to 6 V...16 V) and increased back to operating range. 	<ul style="list-style-type: none"> Ensure that power supply is capable to buffer power interruption up to 20 ms. Ensure that power supply is capable to drive the load, so that switching of loads does not cause a drop of the supply voltage. Check power supply wiring of CPU module. Use separate wires to other heavy loads to avoid voltage drops on the supply cable by other load currents.
		CPU module: 0x003E4006	<p>The system has performed a restart because interferences have been detected in the FLEXBUS+ communication:</p> <ul style="list-style-type: none"> FLEXBUS+ communication (backplane communication to I/O modules and to network modules) disturbed due to EMC disturbance. FLEXBUS+ communication (backplane communication to I/O modules and to network modules) disturbed due to critical fault in any safety I/O module (I/O modules or network module). In this case this is a follow on error and there will be also other critical faults with almost the same time stamp (± 1 s) in the diagnosis history. 	<ul style="list-style-type: none"> Check installation for EMC aspects (FE connection of DIN mounting rail and control cabinet, star wiring of power supply (24 V and 0 V), local separation of power parts and control parts,...) Check the other diagnosis messages with almost the same time stamp.

Table 52:

Error codes and error messages of the MELSEC-WS safety controller and possible rectification measures

- *1 After one of the dual channel inputs is set to ON and another is OFF, when the discrepancy time passes, "Discrepancy error at dual channel input li" should occur. This discrepancy can be cleared when both inputs turn OFF (the left side figure below). However both inputs turn ON during the discrepancy, it is not cleared and this error should occur (the right side figure below).

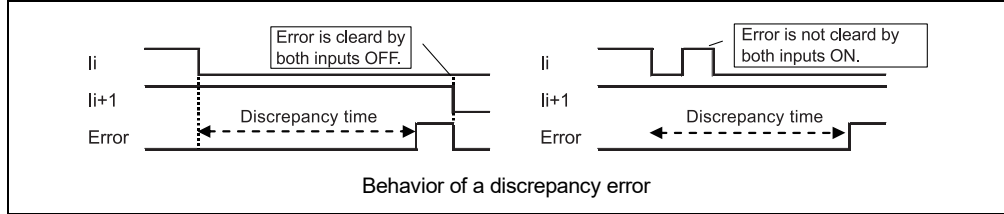

- *2 "Unequal input data from safety I/O module" may occur by following signal inputs.

1) "A dual channel input has 2 single dips (high to low) with a time distance of 2ms."

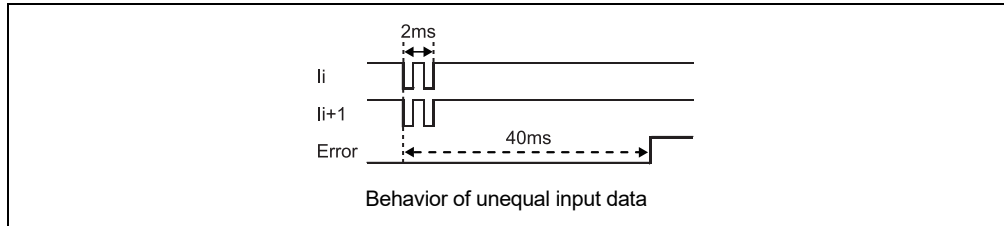

2) "A signal channel input changes state in intervals of 4ms for a duration of 40ms or more."

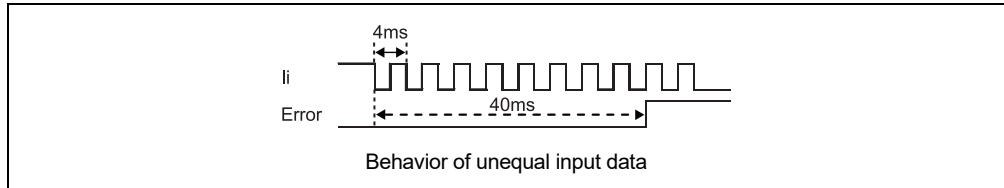

10.3 Additional error displays of SICK EFI-compatible devices

SICK EFI-compatible devices (see Section 5.1) have extended functions in connection with the WS0-CPU1 or WS0-CPU3 module.

Error displays and error elimination are described in the manuals of the corresponding devices.

10.4 Mitsubishi support

If you cannot remedy a malfunction using the information in this chapter, please contact your local Mitsubishi representative.

Note When you send in a WS0-MPL0 or WS0-MPL1 memory plug for repair or analysis, it is returned in the state of delivery, i.e. with an empty configuration. Therefore save your configuration(s) to project files with the Setting and Monitoring Tool.

10.5 Extended diagnostics

The Setting and Monitoring Tool contains extended diagnostic possibilities. If you cannot identify what kind of error is occurring or if you have serviceability problems, it allows you to locate the error more accurately.

For detailed information refer to the Safety Controller Setting and Monitoring Tool Operating Manual.

11 Maintenance

The following sections inform about regular tests and the exchange of MELSEC-WS modules.

Do not try to dismantle, repair or modify the MELSEC-WS modules. This can lead to a loss of the safety function(s). In addition Mitsubishi accepts no claims for liability.

11.1 Regular inspection of the protective device by qualified safety personnel

- Check the system at the inspection intervals specified in the national rules and regulations. This procedure ensures that any changes on the machine or manipulations of the protective device are detected before use/re-use.
- Each safety application must be checked at an interval specified by you. The effectiveness of the protective device must be checked by authorized commissioned persons.
- If any modifications have been made to the machine or the protective device, or if the MELSEC-WS safety controller has been changed or repaired, the system must be checked again as specified in the checklist in Chapter 14.
- Carry out regular or daily inspections in order to keep the MELSEC-WS modules in an optimal operating mode.
- Check whether the implementation of the MELSEC-WS modules fulfills all the technical data of the device.
- Check the mounting conditions and whether the wiring of the MELSEC-WS modules is still correct.
- Regularly verify that the safety functions fulfill the requirements of the application as well as all relevant regulations and standards (e.g. regular checking) in order to ensure the reliability of the safety functions.

11.2 Device replacement

A critical fault in a MELSEC-WS module impairs the complete network. Devices that have critical faults must therefore be repaired or replaced rapidly. We recommend keeping spare devices of the MELSEC-WS modules at hand so that network operation can be re-established as fast as possible.

Safety measures for replacing devices

Observe the following safety measures when replacing MELSEC-WS modules:

- Do not try to dismantle or repair the MELSEC-WS modules. Not only does Mitsubishi accept no claims for liability, but it is also dangerous as it makes verifying the original safety functions impossible.
- Reset the device into a state in which safety is ensured.
- Carry out replacement only when the voltage supply is switched off in order to avoid an electric shock or unexpected device behavior.
- In order to continue using the system configuration check:
 - Is the new module of the same type (same material number) and is there no error at the new module after the replacement?
 - Is the new module plugged in at the same position as the replaced module?
 - Have all connectors been re-connected to the correct terminals?
- Otherwise you have to completely reconfigure and commission the new system, including all the necessary tests (see Chapter 9).

- Note**
- After the replacement ensure that no errors arise with the new MELSEC-WS modules.
 - Always carry out a function test before commissioning a replacement module.
 - SICK EFI-compatible devices do not have to be reconfigured after the replacement of a MELSEC-WS module.
 - If you send in MELSEC-WS modules for repair, generate a report on your project and carry out diagnostics with the Setting and Monitoring Tool, enclose a detailed description of the problem with the device and send the MELSEC-WS modules with all available information to your local Mitsubishi representative.

12 Technical data

12.1 Response times of the MELSEC-WS safety controller

In order to calculate the response times of a MELSEC-WS safety controller, all paths have to be taken into consideration.

Figure 28:
Response times within a
MELSEC-WS safety
controller

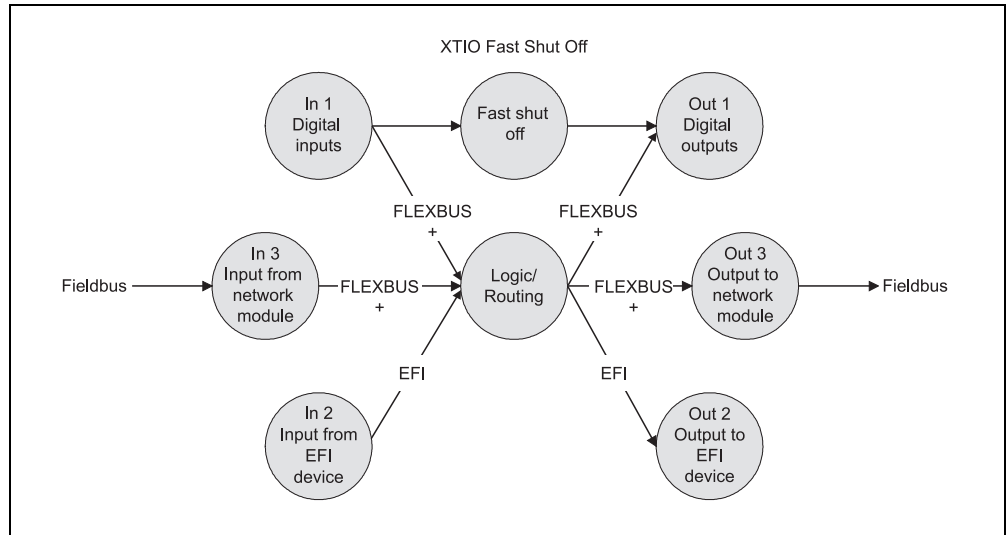

Fast Shut Off

The Fast Shut Off function can be realized on a single WS0-XTIO module. A response time of 8 ms can be reached this way.

Note The Fast Shut Off function has only an effect on the inputs and outputs of the same WS0-XTIO module.

Flexi Link

The response time in a Flexi Link system is increased for a remote input compared to a local input by $4.5 \text{ ms} + 2 \times \text{logic execution time of the remote Flexi Link station}$.

Flexi Line

The response time in a Flexi Line system is increased for a remote input by the input time of the remote station (E1 to E4 from Table 53),

the logic response time of the station that evaluates this input (item 2.a from Table 53)

and

$N \times (10 \text{ ms} + 2 \times \text{Flexi Line update rate})$

Where **N** = the number of connection segments between the stations.

If the Flexi Line function is used in a station, the response time is increased by the logic execution time of this station.

12.1.1 Calculation of the response times

The following table can be used to calculate the response times of corresponding paths within the MELSEC-WS safety controller.

Evaluation			
1. Inputs	Response time of the considered input in the signal path	In1 or In2 or In3 or In4 (from table below)	
2. Logic	a) Response time of CPU module logic	2 × logic execution time ^{*1} Delay through logic application ^{*2} (e.g. On- or Off-delay timer function block)	
	b) Response time of the routing (applies only for output to network module)	No delay	0 ms
	c) Response time of Fast shut off logic (applies only for WS0-XTIO modules)	No delay	0 ms
3. Outputs	Response time of the considered output in the signal path	Out1 or Out2 or Out3 or Out4 (from table below)	
Total response time			

Occurrence	In1: Digital inputs		Out1: Digital outputs	
General	Response time of the sensor ^{*3}		Response time of the actuator ^{*3}	
General	Input processing time	6.5 ms	Output processing time a) From logic (via FLEXBUS+): + 4.5 ms b) From Fast Shut Off: + 1.5 ms	
If On/Off filter enabled	+ min. filter time ^{*4}			
If I1 ... I8 is connected at the test output X1... X8	+ Max. off-on delay ^{*1} of used test output + Long gap of used test output ^{*1}			
a) Safety mats and bumpers	+ Test period ^{*1} of the test output. Use the greater value of both test outputs.			
b) Testable type 4 sensors (e.g. L41)	+ Test period ^{*1} of the test output.			
c) All other sensors	+ Test gap ^{*1} of the test output (if test gap ^{*1} is >1 ms)			
	Total In1		Total Out1	

Occurrence	In2: Input from EFI device		Out2: Output to EFI device	
If EFI functions are used via SICK EFI-compatible devices	Response time of the EFI data source (as a rule a sensor) for external OSSDs via EFI ^{*3} or Flexi Link remote station		Response time of the message receiver (e.g. scanner with protective field switching via EFI) ^{*3}	
Constant:			EFI cycle time of the EFI receiver ^{*3}	
a) Scanner (e.g. S3000)	+ 3.5 ms		+ 24 ms	
b) Light grid (e.g. C4000, M4000)	+ 1.5 ms		+ 4 ms	
c) Flexi Link	+ 0.5 ms		+ 4 ms	
	Total In2		Total Out2	

Occurrence	In3: Network module — data from the network		Out3: Network module — data to the network	
General	Response time field bus for data input to network module (e.g. from programmable controller) ^{*3}		Response time field bus for data from network module (e.g. to programmable controller) ^{*3}	
General	2 × internal update interval for data from the network module to the CPU module ^{*5}		2 × internal update interval for data from the CPU module to the network module ^{*5}	
If 1 network module	+ 5 ms		+ 8 ms	
If 2 network modules	– 4 ms		– 4 ms	
	Total In3		Total Out3	

Table 53:

Calculation of the response times of the MELSEC-WS safety controller in ms

*1 Take the values from the Setting and Monitoring Tool report.

*2 Time values have a tolerance of 10 ms, i.e. for each selected value 10 ms must be considered additionally for the response time. E.g. for a 10 ms off delay, 20 ms must be used for the calculation.

*3 Take values from the corresponding manual.

*4 Switch off is delayed until the signal has been Low for at least the filter time selected. For WS0-XTIO and WS0-XTDI firmware version ≤ V2.00 the filter time is fixed at 8 ms.

- *5 The update interval between the CPU and a network module depends on the amount of data to be transferred and the number of network modules used in the system. Take the values from the Setting and Monitoring Tool report. The update interval amounts to a multiple of 4 ms for each 10 bytes to be transferred to or from the network module if the system contains one network module. If 2 network modules are used the update rate amounts to a multiple of 8 ms.

Example 1:

Calculation of the response time for a MELSEC-WS safety controller consisting of a WS0-CPU1 and a WS0-XTIO:

Figure 29:
Example of a MELSEC-WS
safety controller

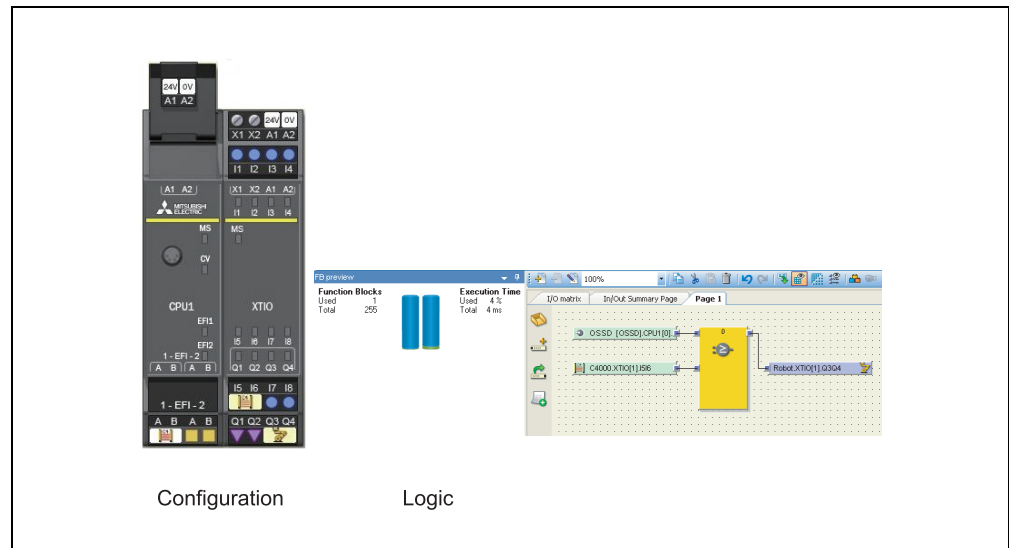

Digital inputs: WS0-XTIO[1].I5I6.C4000: One C4000 safety light curtain

Digital outputs: WS0-XTIO[1].Q3Q4.Robot: Robot, dual-channel

Input from EFI device: WS0-CPU1[0].EFI1.1.OSSD [OSSD]: one C4000 receiver (stand-alone) (safety light curtain with high resolution for hazardous point, hazardous area and access protection at machines)

2 paths have to be considered and calculated separately:

Figure 30:
Response times within a
MELSEC-WS safety
controller

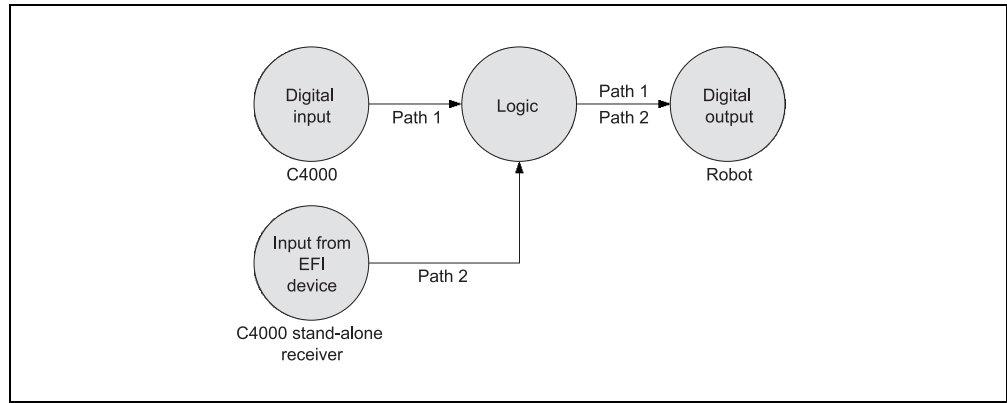

Occurrence	In1: Digital inputs		Out1: Digital outputs	
General	C4000 response time	14.0 ms	Robot response time	40.0 ms
General	Input processing time	6.5 ms	Output processing time	4.5 ms
When On/Off filter	8.0 ms	–		
When X1 ... X8 is connected at the test output		–		
a) Safety mats and bumpers	–			
b) Testable sensors Type 4 (e.g. L41)	–			
c) All other sensors	–			
	Total In1	20.5 ms	Total Out1	44.5 ms

Evaluation			
1. Inputs	Response time of the considered input in the signal path (path 1)	In1	20.5 ms
2. Logic	Response time of the logic	2 × logic execution time	8.0 ms
		Delay through logic application	–
3. Outputs	Response time of the considered output in the signal path (path 1)	Out1	44.5 ms
Total response time			73.0 ms

Table 54: Example for the calculation of the response time of path 1 of a MELSEC-WS safety controller

Occurrence	In2: Input from EFI device		Occurrence	Out1: Digital outputs	
If EFI functions are used via SICK EFI-compatible devices	Response time of the EFI data source (C4000 receiver (stand-alone))	12.0 ms	General	Robot response time	40.0 ms
	Constant (C4000)	1.5 ms	General	Output processing time	4.5 ms
	Total In2	13.5 ms		Total Out1	44.5 ms

Evaluation			
1. Inputs	Response time of the considered input in the signal path (path 2)	In2	13.5 ms
2. Logic	Response time of the logic	2 × logic execution time	8.0 ms
		Delay through logic application	–
3. Outputs	Response time of the considered output in the signal path (path 2)	Out1	44.5 ms
Total response time			66.0 ms

Table 55:
Example for the calculation of the response time of path 2 of a MELSEC-WS safety controller

Example 2:

Calculation of the response time for a MELSEC-WS safety controller:

Figure 31:
Response times within a
MELSEC-WS safety
controller

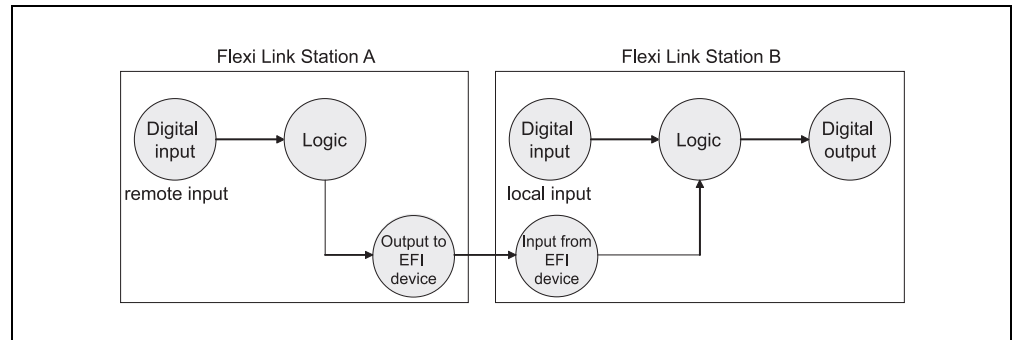

Flexi Link Station A

Logic execution time = 4 ms

Occurrence	In1: Digital inputs	
General	Tactile sensor	0 ms
General	Input processing time	6.5 ms
When On/Off filter	8.0 ms	–
When X1 ... X8 is connected at the test output...		–
	Total In1	6.5 ms

Occurrence	Out2: Output to EFI device	
If EFI functions are used via SICK EFI-compatible devices	Response time of the message receiver (see table below for Flexi Link station B)	
	Constant (Flexi Link)	4 ms
	Total Out2	4 ms

Evaluation			
1. Inputs	Response time of the considered input in the signal path	In1	6.5 ms
2. Logic	Response time of the logic	2 × logic execution time	8.0 ms
		Delay through logic application	–
3. Outputs	Response time of the considered output in the signal path	Out2	4.0 ms
Total response time			18.5 ms

Flexi Link Station B

Logic execution time = 8 ms

Occurrence	In2: Input from EFI device	
If EFI functions are used via SICK EFI-compatible devices	Response time of the EFI data source (see table above for Flexi Link station A)	18.5 ms
	Constant (Flexi Link)	0.5 ms
	Total In2	19.0 ms

Occurrence	Out1: Digital outputs	
General	Response time of the actuator (Robot response time)	40.0 ms
General	Output processing time	4.5 ms
	Total Out1	44.5 ms

Evaluation			
1. Inputs	Response time of the considered input in the signal path	In2	19.0 ms
2. Logic	Response time of the logic	2 × logic execution time	16.0 ms
		Delay through logic application	–
3. Outputs	Response time of the considered output in path 2	Out1	44.5 ms
Total response time (remote input to local output)			79.5 ms

Table 56:
Example for the calculation of the response time of a remote input in a MELSEC-WS safety controller

12.1.2 Min. switch off time

The minimum switch-off time (e.g. of connected sensors) is the minimum time for which a switch-off condition must be present in order to be detected so that error-free switching is possible. The min. switch-off time must be ...

- greater than the logic execution time + 1 ms, and
- greater than the test gap + Long gap, if the input is connected to test output X1...X8 and the test gap is > 1 ms, and
- greater than the test period (i.e. the higher value of the two test outputs used) + the max. Off-on delay, if safety mats or bumpers are used.

*1 Take the values from the Setting and Monitoring Tool report.

12.2 Data sheet

12.2.1 CPU modules: WS0-CPU0, WS0-CPU1 and WS0-CPU3

Safety-related parameters

This information relates to an ambient temperature of +40 °C, which is normally used for the statistical calculation of the values.

Table 57:
Data sheet WS0-CPU0,
WS0-CPU1 and
WS0-CPU3

	WS0-CPU0	WS0-CPU1/3
Safety Integrity Level	SIL3 (IEC 61508)	
SIL claim limit	SILCL3 (IEC 62061)	
Category	Category 4 (EN/ISO 13849-1)	
Performance Level	PLe (EN/ISO 13849-1)	
PFHd (mean probability of a dangerous failure per hour)	1.07×10^{-9}	1.69×10^{-9}
PFHd for Flexi Line station	–	CPU1 : – CPU3 : 0.40×10^{-9}
T _M (mission time)	20 years (EN/ISO 13849-1)	

General data

Protection class	III (IEC 61140)	
Enclosure rating	IP 20 (IEC 60529)	
Ambient temperature in operation	–25 ... +55 °C	
Storage temperature	–25 ... +70 °C	
Humidity	10 ... 95 %, non-condensing	
Climatic conditions	55 °C, 95 % relative humidity (IEC 61131-2), No corrosive gases	
Operating altitude	Max. 2000 m above sea level (80 kPa)	
Vibration resistance	5-150 Hz/1 g (EN 60068-2-6) 10-500 Hz/5 g (IEC 60068-2-6)	
Shock resistance		
Continuous shock	10 g, 16 ms (IEC 60068-2-29)	
Single shock	30 g, 11 ms (IEC 60068-2-27)	
Electromagnetic compatibility	Class A (EN 61000-6-2, EN 61000-6-4)	
Number of EFI interfaces	0	2
Number of Flexi Line interfaces	0	CPU1 : 0 CPU3 : 2
Data interface	Backplane bus (FLEXBUS+)	
Configuration interface	RS-232	CPU1 : RS-232 CPU3 : RS-232, USB2.0(miniB)

	WS0-CPU0	WS0-CPU1/3
Cross-section of connecting wires	Single-core or finely stranded: 1 × 0.14 ... 2.5 mm ² (26 to 13 AWG) or 2 × 0.14 ... 0.75 mm ² (26 to 18 AWG) Finely stranded with ferrules 1 × 0.25 ... 2.5 mm ² (23 to 13 AWG) or 2 × 0.25 ... 0.5 mm ² (23 to 20 AWG)	
EFI connection method, Flexi Line connection method	–	Dual level spring clamp terminals
Cross-section of EFI connecting wires	–	Single-core or finely stranded: 0.2 to 1.5 mm ² (24 to 16 AWG) Finely stranded with ferrules: 0.25 to 1.5 mm ² (23 to 16 AWG)
Dimensions (W × H × D)	22.5 × 96.5 × 120.8 mm	22.5 × 101.7 × 120.8 mm
Weight	111 g (± 5%)	CPU1 : 119 g (± 5%) CPU3 : 133 g (± 5%)

Power supply (A1, A2) via memory plug WS0-MPL0 or WS0-MPL1

Supply voltage	24 V DC (16.8 ... 30 V DC)
Supply voltage UL/CSA applications	24 V DC
Type of supply voltage	PELV or SELV The current of the power supply unit for the CPU module has to be limited to a maximum of 4 A – either by the power supply unit itself or by a fuse
Overvoltage category	II (EN 61131-2)
Power consumption	Max. 2.5 W
Switch-on time	Max. 18 s

12.2.2 WS0-XTIO safety input/output combined module

Safety-related parameters

This information relates to an ambient temperature of +40 °C, which is normally used for the statistical calculation of the values.

Table 58:
Data sheet WS0-XTIO

Safety Integrity Level	SIL3 (IEC 61508)
SIL claim limit	SIL CL3 (IEC 62061)
Category* ¹ For single channel outputs with test pulses enabled for all safe outputs (Q1...Q4) For single channel outputs with test pulses disabled for this or any other safe output (Q1...Q4) For dual channel outputs with or without test pulses disabled for this or any other safe output (Q1...Q4)	Category 4 (EN/ISO 13849-1) Category 3 (EN/ISO 13849-1) Category 4 (EN/ISO 13849-1)
Performance Level	PL e (EN/ISO 13849-1)
PFHd (mean probability of a dangerous failure per hour)* ¹ For single channel outputs For dual channel outputs	4.8 × 10 ⁻⁹ 0.9 × 10 ⁻⁹
T _M (mission time)	20 years (EN/ISO 13849)* ²

*1 Applies for single channel outputs and for dual channel outputs.

*2 If safe outputs are used without test pulses, at least once per year either all safe outputs without test pulses have to be switched off at the same time for at least 1 second or alternatively a power reset has to be performed.

General data

Protection class	III (IEC 61140)
Enclosure rating	Terminals: IP 20 (IEC 60529) Housing: IP 40 (IEC 60529)
Ambient temperature in operation	-25 ... +55 °C
Storage temperature	-25 ... +70 °C
Humidity	10 ... 95 %, non-condensing
Climatic conditions	55 °C, 95 % relative. humidity (IEC 61131-2), No corrosive gases
Vibration resistance	5-150 Hz/1 g (IEC 60068-2-6) 10-500 Hz/3 g RMS (EN 60068-2-64)
Shock resistance	
Continuous shock	10 g, 16 ms (IEC 60068-2-27)
Single shock	30 g, 11 ms (IEC 60068-2-27)
Electromagnetic compatibility	Class A (EN 61000-6-2, EN 61000-6-4)
System connection	Dual level spring clamp terminals
Power input via FLEXBUS+ without currents to X1, X2	Max. 2.2 W
Cross-section of connecting wires	Single-core or finely stranded: 0.2 to 1.5 mm ² (24 to 16 AWG) Finely stranded with ferrules: 0.25 to 1.5 mm ² (23 to 16 AWG)
Data interface	Backplane bus (FLEXBUS+)
Dimensions (W × H × D)	22.5 × 106.5 × 120.8 mm
Weight	164 g (± 5%)

Power supply unit (A1, A2)

Supply voltage	24 V DC (16.8 V DC ... 30 V DC)
Supply voltage UL/CSA applications	24 V DC
Type of supply voltage	PELV or SELV The current of the power supply unit for the module has to be limited to a maximum of 4 A – either by the power supply unit itself or by a fuse.
Power consumption	Max. 120 W (30 V × 4 A), determined by the load at the outputs Q1 to Q4, plus max. 1 W power input for the internal circuit
Switch-on time	Max. 18 s
Short-circuit protection	4 A gG (with tripping characteristic B or C)

Input circuit (I1 ... I8)

Input voltage High	13 ... 30 V DC
Input voltage Low	-5 ... +5 V DC
Input current High	2.4 ... 3.8 mA
Input current Low	-2.5 ... 2.1 mA
Input reverse current in case of ground interruption ^{*3} Hardware version < V1.10.1 Hardware version ≥ V1.10.1	Max. 20 mA 1.5 kΩ effective reverse resistance to power supply Max. 2 mA
Switching current (with mechanical contacts)	14.4 mA at 5 V 3 mA at 24 V
Input pulse filtering (pulses within these limits have no effect) Pulse width Pulse period	Max. 0.9 ms Min. 4 ms
Input capacitance	Max. 10 nF + 10 %
Discrepancy times	4 ms ... 30 s, configurable
Number of inputs	8

*3 Do not switch other safe inputs in parallel, if the reverse current could lead to a High state at the other input.

Test outputs (X1, X2)

Number of outputs	2 (with 2 test pulse generators)
Output type	PNP semiconductor, short-circuit protected, short-circuit monitoring (selectable)
Output voltage High	15 ... 30 V DC (max. 1.8 V drop to terminal A1 of CPU module)
Output resistance Low	≤33 Ω ± 10 %, current limited at approx. 10 mA
Output current	Max. 120 mA at each test output (X1 or X2) This means that a maximum of 8 testable sensor cascades per module with max. 30 mA each are possible. The total current for the MELSEC-WS safety controller for all outputs (X1...X8 and XY1...XY2) is limited to a maximum of 1.28 A. This corresponds to e.g. a maximum of 32 testable sensor cascades with 30 mA each plus 64 tactile sensors on inputs on safety I/O modules with 5 mA each.
Test pulse rate (test period)	1 ... 25 Hz, configurable
Test pulse duration (test gap)	1 ... 100 ms, configurable
Load capacity	1 μF for test gap ≥ 4 ms 0.5 μF for test gap 1 ms
Cable resistance	< 100 Ω

Safe outputs (Q1 ... Q4)

Number of outputs	4
Output type	PNP semiconductor, short-circuit protected, short-circuit monitoring (selectable)
Output voltage High	16 ... 30 V DC (max. 0.8 V drop to terminal A1 of this module)
Leakage current Low Normal operation Fault case ⁴ Hardware version < V1.10.1 Hardware version ≥ V1.10.1	Max. 0.1mA Max. 1.6 mA Max. 2.0 mA
Output current	Max. 2.0 A
Total current I _{sum} T _A ≤ 45 °C T _A ≤ 55 °C For UL/CSA applications	Max. 4.0 A Max. 3.2 A Max. 3.2 A
Test pulse width ⁵	< 650 μs or disabled ^{6,7}
Test pulse rate	Max. 5 Hz
Capacitive load	≤ 0.5 μF
Cable resistance ⁸	Max. 5 Ω (e.g. 100 m × 1.5 mm ² = 1.2 Ω)
Max. permitted coil energy without external protection elements ⁹ Hardware version V1.00.0 Hardware version ≥ V1.01.0	0.22 J 0.37 J
Response time	Depending on the logic configuration, for details see Table 53.
Data interface	Backplane bus(FLEXBUS+)

- *4 In the case of a fault (0 V cable open circuit) with a load resistance of min. 2.5 kΩ, maximally the leakage current flows from the safe output. For smaller load resistors the leakage current may be greater but in this case the output voltage will be < 5 V. The connected device, e.g. relay or fail-safe programmable controller) must detect this status as Low.
- *5 When active, the outputs are tested cyclically (brief switching to Low). When selecting the downstream controllers, make sure that the test pulses do not result in deactivation when using the above parameters or disable the test pulses on the outputs.
- *6 If safe outputs are used without test pulses, at least once per year either all safe outputs without test pulses have to be switched off at the same time for at least 1 second or alternatively a power reset has to be performed.
- *7 If safe outputs are used without test pulses: Use protected or separate cabling for the safe outputs without test pulses, because a short circuit to 24 V can not be detected if the safe output is High. This could inhibit the switch-off capability for the other safe outputs in case of an internal detected hardware failure due to reverse powering.
- *8 Make sure to limit the individual line core resistance to the downstream controller to this value to ensure that a short-circuit between the outputs is safely detected. (Also note IEC 60204 Electrical Machine Equipment, Part 1: General Requirements.)
- *9 Examples for resulting max. coil inductivity:
 HW V1.00.0: 1760 mH @ 0.5A, 440 mH @ 1A, 110 mH @ 2A
 HW V1.01.0: 2960 mH @ 0.5A, 740 mH @ 1A, 185 mH @ 2A

12.2.3 WS0-XTDI safety input module

Safety-related parameters

This information relates to an ambient temperature of +40 °C, which is normally used for the statistical calculation of the values.

Table 59:
Data sheet WS0-XTDI

Safety Integrity Level	SIL3 (IEC 61508)
SIL claim limit	SIL CL3 (IEC 62061)
Category	Category 4 (EN/ISO 13849-1)
Performance Level	PLe (EN/ISO 13849-1)
PFHd (mean probability of a dangerous failure per hour)	0.4×10^{-9}
T _M (mission time)	20 years (EN/ISO 13849)

General Data

Protection class	III (IEC 61140)
Enclosure rating	Terminals: IP 20 (IEC 60529) Housing: IP 40 (IEC 60529)
Ambient temperature in operation	-25 ... +55 °C
Storage temperature	-25 ... +70 °C
Humidity	10 ... 95 %, non-condensing
Climatic conditions	55 °C, 95 % relative. humidity (IEC 61131-2), No corrosive gases
Vibration resistance	5-150 Hz/1 g (EN 60068-2-6) 10-500 Hz/3 g RMS (EN 60068-2-64)
Shock resistance	
Continuous shock	10 g, 16 ms (IEC 60068-2-27)
Single shock	30 g, 11 ms (IEC 60068-2-27)
Electromagnetic compatibility	Class A (EN 61000-6-2, EN 61000-6-4)
System connection	Dual level spring clamp terminals
Power input via FLEXBUS+ without currents to X1 ... X8	Max. 2 W
Cross-section of connecting wires	Single-core or finely stranded: 0.2 to 1.5 mm ² (24 to 16 AWG) Finely stranded with ferrules: 0.25 to 1.5 mm ² (23 to 16 AWG)
Dimensions (W × H × D)	22.5 × 106.5 × 120.8 mm
Weight	139 g (± 5%)

Safe inputs (I1 ... I8)

Input voltage High	13 ... 30 V DC
Input voltage Low	-5 ... +5 V DC
Input current High	2.4 ... 3.8 mA
Input current Low	-2.5 ... 2.1 mA
Input reverse current in case of ground interruption ¹	
Hardware version < V1.10.0	Max. 20 mA 1.5 kΩ effective reverse resistance to power supply
Hardware version ≥ V1.10.0	Max. 2 mA
Switching current (with mechanical contacts)	14.4 mA at 5 V 3 mA at 24 V
Input capacitance	Max. 10 nF + 10 %
Discrepancy times	4 ms ... 30 s, configurable
Number of inputs	8

Test outputs (X1 ... X8)

Number of outputs	8 (with 2 test pulse generators)
Output type	PNP semiconductor, short-circuit protected, cross-circuit monitoring
Output voltage	15 ... 30 V DC (max. 1.8 V drop to terminal A1 of CPU module)
Output resistance Low	$\leq 33 \Omega \pm 10 \%$, current limited at approx. 10 mA
Output current	<p>Max. 120 mA at each of the two test signal generators (X1/X3/X5/X7 or X2/X4/X6/X8)</p> <p>This means that a maximum of 8 testable sensor cascades per module with max. 30 mA each are possible.</p> <p>The total current for the MELSEC-WS safety controller for all outputs (X1...X8 and XY1...XY2) is limited to a maximum of 1.28 A. This corresponds to e.g. a maximum of 32 testable sensor cascades with 30 mA each plus 64 tactile sensors on inputs on safety I/O modules with 5 mA each.</p>
Test pulse rate (test period)	1 ... 25 Hz, configurable
Test pulse duration (test gap)	1 ... 100 ms, configurable
Load capacity	1 μ F for test gap \geq 4 ms 0.5 μ F for test gap 1 ms
Cable resistance	$< 100 \Omega$

*1 Do not switch other safety inputs in parallel, if the reverse current could lead to a High state at the other input.

12.2.4 WS0-4RO safety relay output module

Table 60:
Data sheet WS0-4RO

Supply circuit (via WS0-CPUx)

Power consumption	Max. 3.2 W
-------------------	------------

Input circuit B1, B2

Input voltage ON	18 V DC ... 30 V DC
------------------	---------------------

Output circuit (13-14, 23-24, 33-34, 43-44, Y1-Y2, Y3-Y4)

Number of N/O contacts	4 (13-14, 23-24, 33-34, 43-44)
Number of N/C contacts	2 (Y1-Y2, Y3-Y4)
Switching voltage	230 V AC ^{*1} (5 ... 253 V AC)
	230 V DC ^{*1} (5 ... 253 V DC)
Switching current	10 mA ... 6 A
Mechanical endurance	Min. 10 × 10 ⁶
Electrical endurance	See Figure 33.
Minimum contact load with U _n = 24 V DC	50 mW
Total current	8 A
Response time ^{*2}	30 ms
Type of output	Potential-free N/O contacts, positively guided
Contact material	AgSnO ₂
Output circuit fusing	6 A (gG), per current path
Usage category	AC-15: U _e 250 V, I _e 3 A
	DC-13: U _e 24 V, I _e 3 A

*1 See Figure 32 or Figure 33.

*2 Time from LOW on B1/B2 to relay drop-out.

Figure 32:
DC load breaking capacity
safety relay output module
WS0-4RO

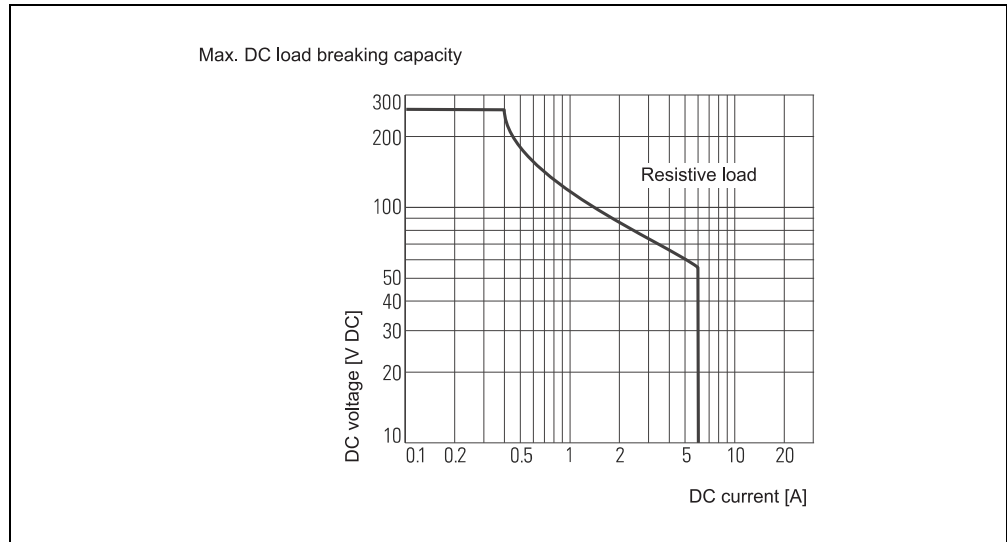
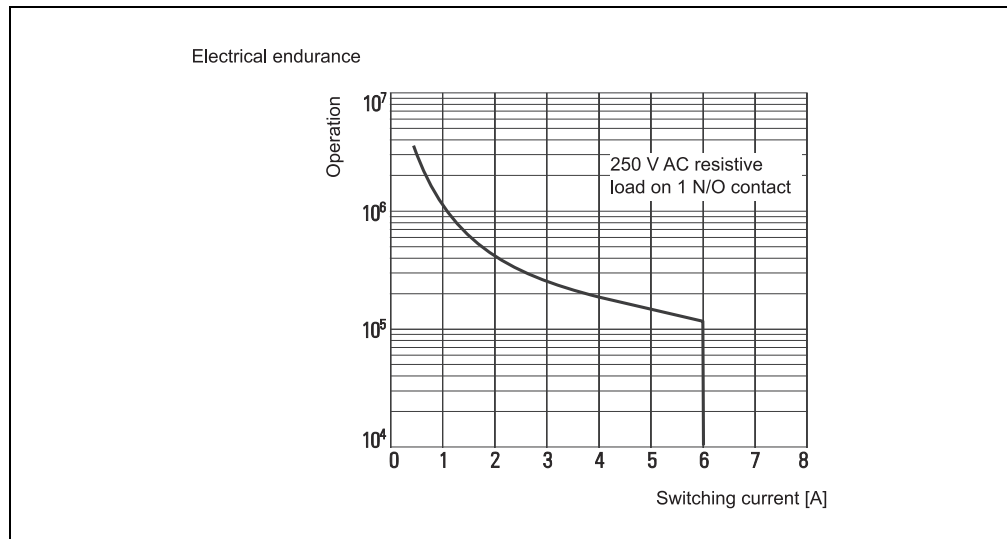

Figure 33:
Electrical endurance safety
relay output module WS0-
4RO



Output circuit (Y14, Y24)

Type of output	N/O contact, connected to internal 24 V DC, positively guided, current-limited
Number of N/O contacts Y14/24	2
Output voltage	24 V DC (16 ... 30 V DC)
Output current ^{*3}	Max. 75 mA
Load capacity	200 nF

General data

Electrical isolation	
Supply circuit-input circuit	No
Supply circuit-output circuit	Yes
Input circuit-output circuit	Yes
Weight (without packaging)	186 g (± 5%)

Operating data

Ambient operating temperature	-25 °C ... 55 °C
Storage temperature	-25 °C ... 70 °C
Air humidity	10 % to 95 %, non-condensing
Climatic conditions	IEC 61131-2, No corrosive gases

Mechanical strength

Vibration resistance	5-150 Hz/1 g (EN 60068-2-6) 10-500 Hz/3 g RMS (EN 60068-2-64)
----------------------	--

Electrical safety IEC 61131-2

Impulse voltage withstand level (U _{imp})	4 kV
Overvoltage category	II
Pollution degree	2 inside, 3 outside
Rated voltage	300 V AC
Enclosure rating housing/terminals	IP 40/IP 20 (IEC 60529)
Electromagnetic compatibility	IEC 61131-2, EN 61000-6-2, EN 61000-6-4, EN 55011 class A

Terminal and connection data

Cross-section of connecting wires	Single-core or finely stranded: 0.2 to 1.5 mm ² (24 to 16 AWG) Finely stranded with ferrules: 0.25 to 1.5 mm ² (23 to 16 AWG)
Insulation stripping length	8 mm
Maximum break-away torque	0.6 N·m

*3 The total output current is limited. Maximum total current for all safety relay output modules on Y14 and Y24 is I < 80 mA.

Safety specific characteristics

All these data are based on an ambient temperature of +40 °C.

Safety integrity level	SIL3 (IEC 61508)
SIL claim limit	SILCL3 (IEC 62061)
Category	Category 4 (EN/ISO 13849-1)
Performance Level	PL e (EN/ISO 13849-1)
PFD	1.6×10^{-7}
PFHd at I = 0.75 A, switching frequency = h ⁻¹ (see also Table 61)	1.2×10^{-9}
B10d value, switching frequency = h ⁻¹	0.75 A (AC 15)/4,150,000 (see also Table 61)
SFF	99.6 %
DC	99 %
T _M (mission time)	Depending on PFHd value, ambient temperature, load and switching operations (see Table 61)
No. of mechanical switching operations	Min. 200,000

Table 61:
PFHd values WS0-4R0

Load type	I[A]	Switching frequency	Switching operations per annum	B10d	PFHd
AC15	0.1	1/h	8760	10,000,000	5.00×10^{-10}
	0.75	1/h	8760	4,150,000	1.20×10^{-9}
	3	1/h	8760	400,000	1.20×10^{-08}
	5	1/h	8760	70,000	7.20×10^{-08}
DC13	1	1/h	8760	2,000,000	2.50×10^{-09}
	3	1/h	8760	450,000	1.10×10^{-08}
AC1	2	1/h	8760	1,000,000	5.00×10^{-09}
	4	1/h	8760	600,000	8.40×10^{-09}



In order to reach SILCL3 in accordance with IEC 62061 (see chapter 12), the following test must be made at least every 365 days:

- The MELSEC-WS safety controller must be powered down.
- The MELSEC-WS safety controller must be powered up.
- All safety functions of the connected safety sensors must be verified.

12.3 Dimensional drawings

12.3.1 WS0-CPUx module with memory plug

Figure 34:
Dimensional drawing
WS0-CPUx (mm)

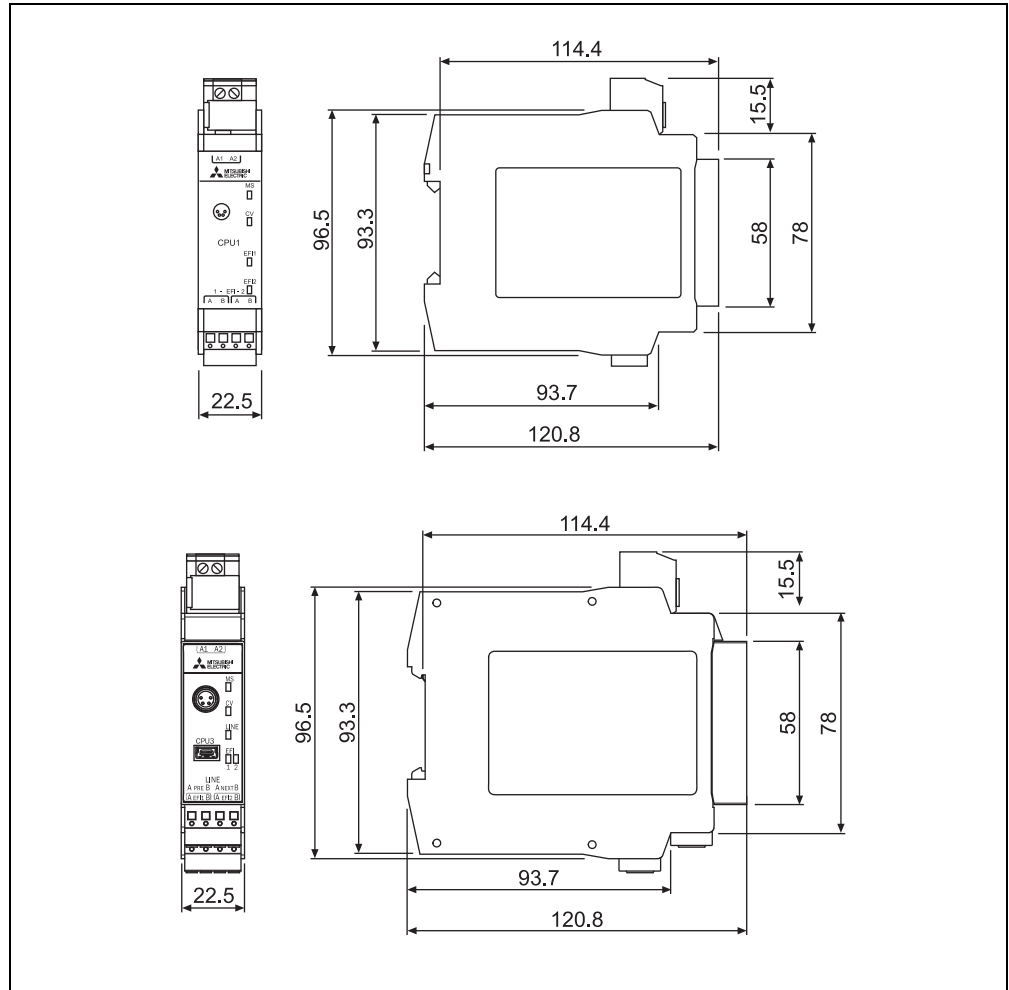

12.3.2 WS0-XTIO module, WS0-XTDI module, and WS0-4RO module

Figure 35:
Dimensional drawing
WS0-XTIO, WS0-XTDI,
WS0-4RO (mm)

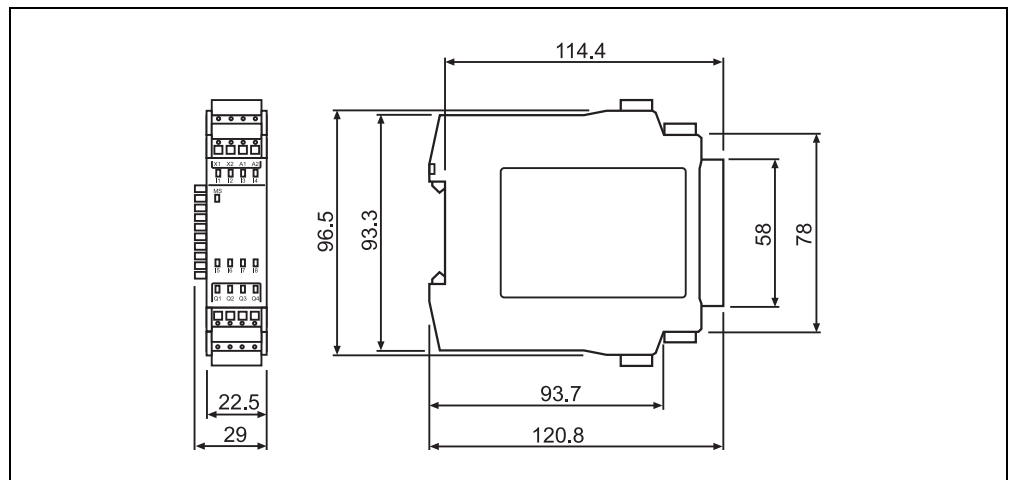

13 Ordering information

13.1 Available modules and accessories

Table 62:
Device types of MELSEC-
WS series

Device type	Part
WS0-MPL000201	Memory plug for WS0-CPU0 or WS0-CPU1
WS0-MPL100201	Memory plug for WS0-CPU3
WS0-CPU000200	CPU module Dual level spring clamp terminals
WS0-CPU130202	CPU module 2 EFI connections, dual level spring clamp terminals
WS0-CPU320202	CPU module 2 EFI connections, 1 Flexi Line connection, dual level spring clamp terminals
WS0-XTIO84202	Safety I/O combined module 8 inputs/4 outputs, dual level spring clamp terminals
WS0-XTDI80202	Safety input module 8 inputs, dual level spring clamp terminals
WS0-4RO4002	Safety relay output module 4 NO contacts and 2 24 V DC signal outputs, plug-in terminals
WS0-C20R2	Configuration cable 2 m, M8, D-SUB
WS0-C20M8U	Configuration cable 2 m, M8, USB-A
WS0-UC-232A	RS-232 USB converter, RS-232 to USB
WS0-GETH00200	Ethernet interface module for Ethernet
WS0-GCC100202	CC-Link interface module for CC-Link
WS0-TBC4	4 dual level spring clamp terminals (for replacement)
WS0-TBS4	4 screw terminals (for replacement)

Table 63:
USB cable

Model	Type
USB cable (MR-J3USBCBL3M)	USB cable (USB A type - USB miniB type)

13.2 Recommended products

The following is the reference product of a Flexi Link cable.

Table 64:
The reference product of a
Flexi Link cable

Model	Type	Manufacturer	Product No.
Flexi Link cable	Shielded, twisted pair, 2 × 2 × 0.34mm ² , per meter	SICK	6034249

The following table lists the reference products of a Flexi Line cable.

Table 65:
The reference product of a
Flexi Line cable

Model	Type	Manufacturer	Product No.
UNITRONIC BUS CAN cable	Shielded, twisted pair, 1 × 2 × 0.75mm ²	LAPP	2170269
Flexi Line cable	PVC, per meter, 40m maximum	SICK	6029448

14 Annex

14.1 EU declaration of conformity

Figure 36:
EU declaration of
conformity for MELSEC-WS
safety controller



EU DECLARATION OF CONFORMITY

We,

Manufacturer : MITSUBISHI ELECTRIC CORPORATION

Address : TOKYO 100-8310, JAPAN
(Place of Declare)

Brand Name :  MITSUBISHI ELECTRIC

declare under our sole responsibility that the product

Description : Safety Controller

Type of Model : WS series

Notice : Refer to next page about each type name

to which this declaration relates is in conformity with the following standard and directive.

Directive		Harmonized Standard	Notified Body
EMC Directive	2014/30/EU	EN61000-6-2:2005 EN61000-6-4:2007 + A1:2011 EN55011:2016 + A1:2017 + A11:2020	—
Machinery Directive	2006/42/EC	EN ISO 13849-1:2015	1
RoHS Directive	2011/65/EU,(EU)2015/863*1	EN IEC 63000:2018	—

*1: Category 9 "Industrial monitoring and control instruments" is applicable.

This declaration is based on the conformity assessment of following Notified Body		
No.	Name and Address	Identification Number
1	TÜV RHEINLAND INDUSTRIE SERVICE GMBH, Am Grauen Stein D-51105 Köln Germany	0035

Authorized representative in Europe (The person authorized to compile the Technical file or relevant Technical documentation)
Hartmut Pütz FA Product Marketing, Director, MITSUBISHI ELECTRIC EUROPE B.V., German Branch Mitsubishi-Electric-Platz 1, 40882 Ratingen, Germany
Issue Date (Date of Declaration): 23 Sep. 2022

Signed for and on behalf of

(Signature) Tokiharu Miyoshi

[Tokiharu Miyoshi]
Senior Manager, FA Hardware Platform Development Section
FA Systems Dept. 1
MITSUBISHI ELECTRIC CORPORATION NAGOYA WORKS

Appendix List of type name to declare

WS0-4RO4002	*1, *2, *3
WS0-CPU000200	*1, *2
WS0-CPU000200(C)	*1, *2
WS0-CPU130202	*1, *2
WS0-CPU130202(C)	*1, *2
WS0-CPU320202	*1, *2
WS0-CPU320202(C)	*1, *2
WS0-CPU000220	*1, *2
WS0-MPL000201	*1, *2
WS0-MPL000201(C)	*1, *2
WS0-MPL100201	*1, *2
WS0-MPL100201(C)	*1, *2
WS0-XTDI80202	*1, *2
WS0-XTDI80202(C)	*1, *2
WS0-XTIO84202	*1, *2
WS0-XTIO84202(C)	*1, *2
WS0-GEIP00200	*1, *2

*1: EN61000-6-2:2005

*2: EN61000-6-4:2007 + A1:2011

*3: EN55011:2016 + A1:2017 + A11:2020

14.2 UK declaration of conformity

Figure 37:
UK declaration of
conformity for MELSEC-WS
safety controller



ORIGINAL

UK DECLARATION OF CONFORMITY

We,

Manufacturer : MITSUBISHI ELECTRIC CORPORATION

Address : TOKYO 100-8310, JAPAN
(Place of Declare)

Brand Name :  MITSUBISHI ELECTRIC

declare under our sole responsibility that the product

Description : Programmable Controller

Type of Model : WS series

Notice : Refer to next page about each type name

to which this declaration relates is in conformity with the following standard and statutory instrument.

Statutory Instrument [SI]	Designated Standard	CAB
Electromagnetic Compatibility Regulations 2016 No.1091 [as amended]	EN61000-6-2:2005 EN61000-6-4:2007 + A1:2011 EN55011:2016 + A1:2017 + A11:2020	—
Supply of Machinery (Safety) Regulations 2008 No.1597 [as amended]	EN ISO 13849-1:2015	1
The Restriction of the Use of Certain Hazardous Substances [RoHS] in Electrical and Electronic Equipment Regulations 2012 No.3032 [as amended]	EN IEC 63000:2018	—

Conformity Assessment Body [CAB]			
No.	Name and Address	Identification Number	Issued certificate No.
1	TÜV RHEINLAND INDUSTRIE SERVICE GMBH, Am Grauen Stein, 51105 Köln, Germany	0035	01/205/5200.03/20
Designated Standard		EN ISO 13849-1:2015	

Issue Date (Date of Declaration): 23 Sep. 2022

Signed for and on behalf of

(Signature) Tokiharu Miyoshi

[Tokiharu Miyoshi]
Senior Manager, FA Hardware Platform Development Section
FA Systems Dept.1
MITSUBISHI ELECTRIC CORPORATION NAGOYA WORKS

Appendix List of type name to declare

WS0-4RO4002	#####	*1,*2,*3
WS0-CPU000200	#####	*1,*2
WS0-CPU000200(C)	#####	*1,*2
WS0-CPU130202	#####	*1,*2
WS0-CPU130202(C)	#####	*1,*2
WS0-CPU320202	#####	*1,*2
WS0-CPU320202(C)	#####	*1,*2
WS0-CPU000220	#####	*1,*2
WS0-MPL000201	#####	*1,*2
WS0-MPL000201(C)	#####	*1,*2
WS0-MPL100201	#####	*1,*2
WS0-MPL100201(C)	#####	*1,*2
WS0-XTDI80202	#####	*1,*2
WS0-XTDI80202(C)	#####	*1,*2
WS0-XTIO84202	#####	*1,*2
WS0-XTIO84202(C)	#####	*1,*2
WS0-GEIP00200	#####	*1,*2

(#:0-9, A-Z)

*1: EN61000-6-2:2005

*2: EN61000-6-4:2007 + A1:2011

*3: EN55011:2016 + A1:2017 + A11:2020

14.3 Manufacturers checklist

Table 66:
Example of the checklist for
installation of the MELSEC-
WS safety controller

Checklist for the manufacturer/installer for installation of the MELSEC-WS safety controller		
<p>The specifications for the following items listed must be available at least for the initial commissioning. They are dependent on the application, whose requirement must be checked by the manufacturer/installer.</p> <p>This checklist should be retained/stored with the machine documentation so that you can use it as a reference for periodical tests.</p>		
1. Have the safety rules and regulations been observed in compliance with the directives/standards applicable to the machine?	Yes <input type="checkbox"/>	No <input type="checkbox"/>
2. Are the applied directives and standards listed in the declaration of conformity?	Yes <input type="checkbox"/>	No <input type="checkbox"/>
3. Does the protective device comply with the required category?	Yes <input type="checkbox"/>	No <input type="checkbox"/>
4. Are the required protective measures against electric shock in effect (protection class)?	Yes <input type="checkbox"/>	No <input type="checkbox"/>
5. Has the protective function been checked in compliance with the test notes in this documentation? Especially:	Yes <input type="checkbox"/>	No <input type="checkbox"/>
<ul style="list-style-type: none"> • Functional check of the command devices, sensors and actuators connected to the safety controller • Test of all switch-off paths 		
6. Are you sure that the safety controller was tested fully for safety functionality after each configuration change?	Yes <input type="checkbox"/>	No <input type="checkbox"/>
<p>This checklist does not replace initial commissioning and regular tests by qualified safety personnel.</p>		

14.4 Wiring examples

(1) Wiring of the emergency stop pushbuttons, start switches, stop switches, and reset switches

a) Dual-channel wiring (with test pulse outputs)

Connect emergency stop pushbuttons to the MELSEC-WS safety controller as shown below.

Figure 38:
Wiring example of
emergency stop
pushbuttons

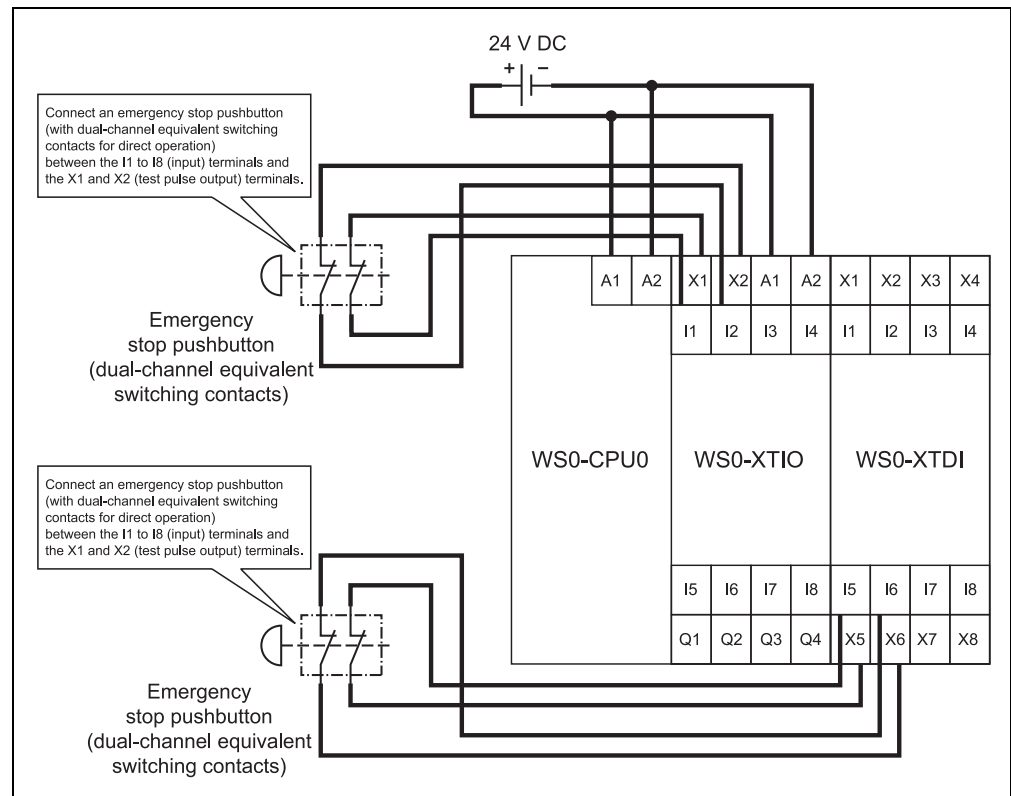

* Use the following terminal combinations for dual-channel input wiring.

WS0-XTIO: ((I1 and X1) (I2 and X2)), ((I3 and X1) (I4 and X2)), ((I5 and X1) (I6 and X2)), ((I7 and X1) (I8 and X2))

WS0-XTDI: ((I1 and X1) (I2 and X2)), ((I3 and X3) (I4 and X4)) to ((I7 and X7) (I8 and X8))

b) Single-channel wiring (without test pulse outputs)
 Connect start switches, stop switches, and reset switches to the MELSEC-WS safety controller as shown below.

Figure 39:
 Wiring example of start switches, stop switches, and reset switches

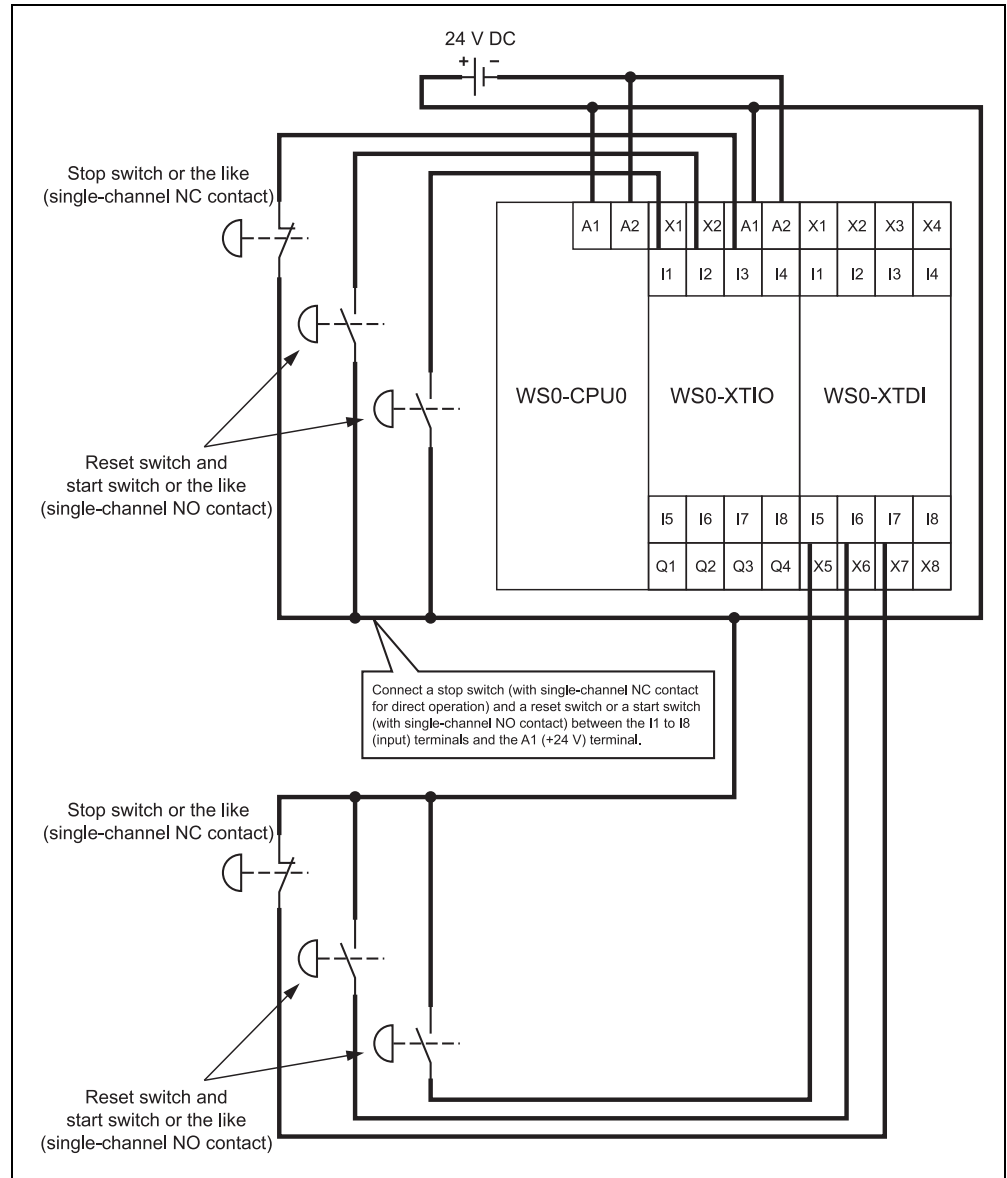

(2) Wiring of safety switches

Connect a safety switch to the MELSEC-WS safety controller as shown below.

Figure 40: Wiring example of safety switches

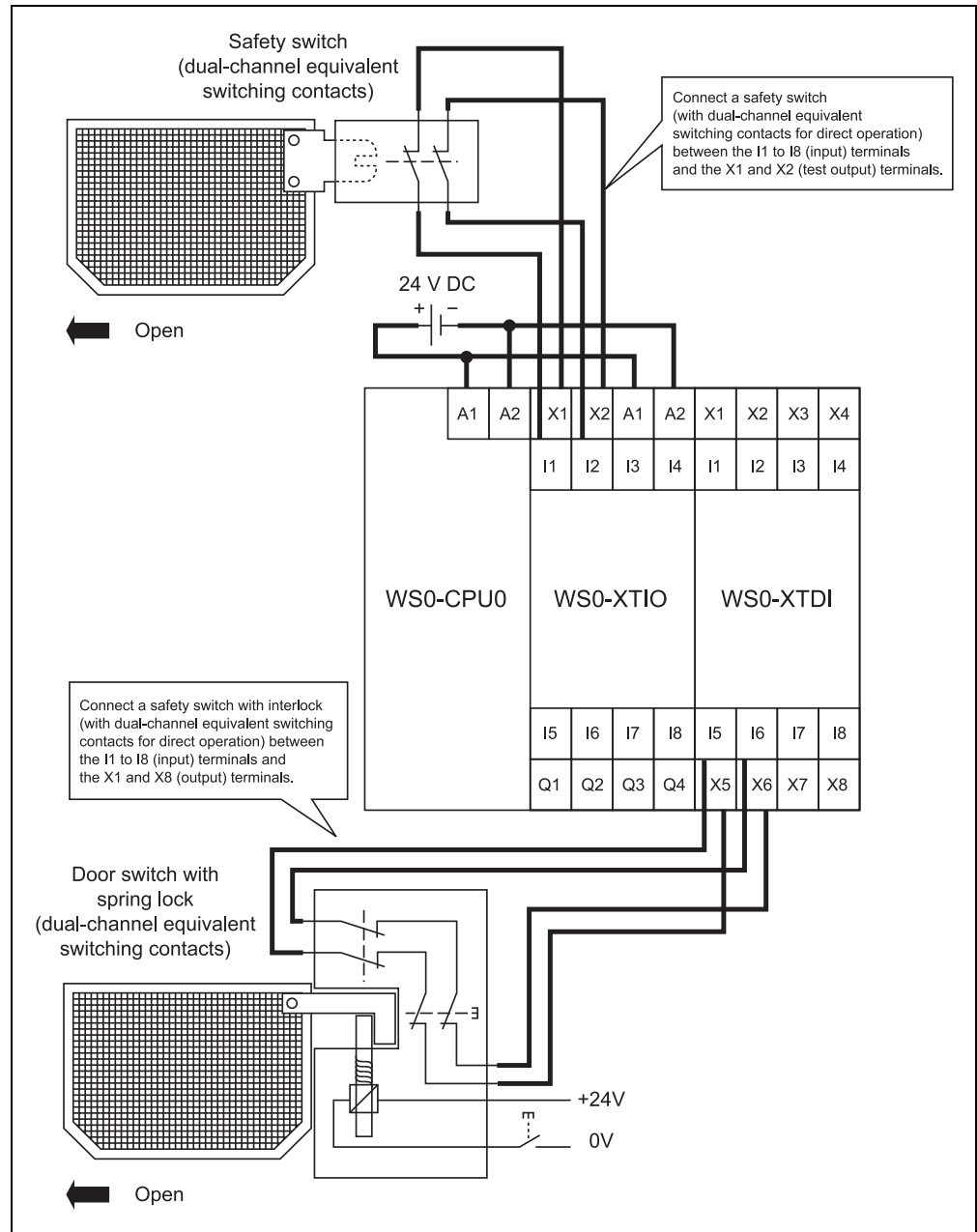

* Use the following terminal combinations for dual-channel input wiring.

WS0-XTIO: ((I1 and X1) (I2 and X2)), ((I3 and X1) (I4 and X2)), ((I5 and X1) (I6 and X2)), ((I7 and X1) (I8 and X2))

WS0-XTDI: ((I1 and X1) (I2 and X2)), ((I3 and X3) (I4 and X4)) to ((I7 and X7) (I8 and X8))

(3) Wiring of light curtains and laser scanners

Connect a light curtain and a laser scanner to the MELSEC-WS safety controller as shown below.

Figure 41:
Wiring example of light
curtain and laser scanner

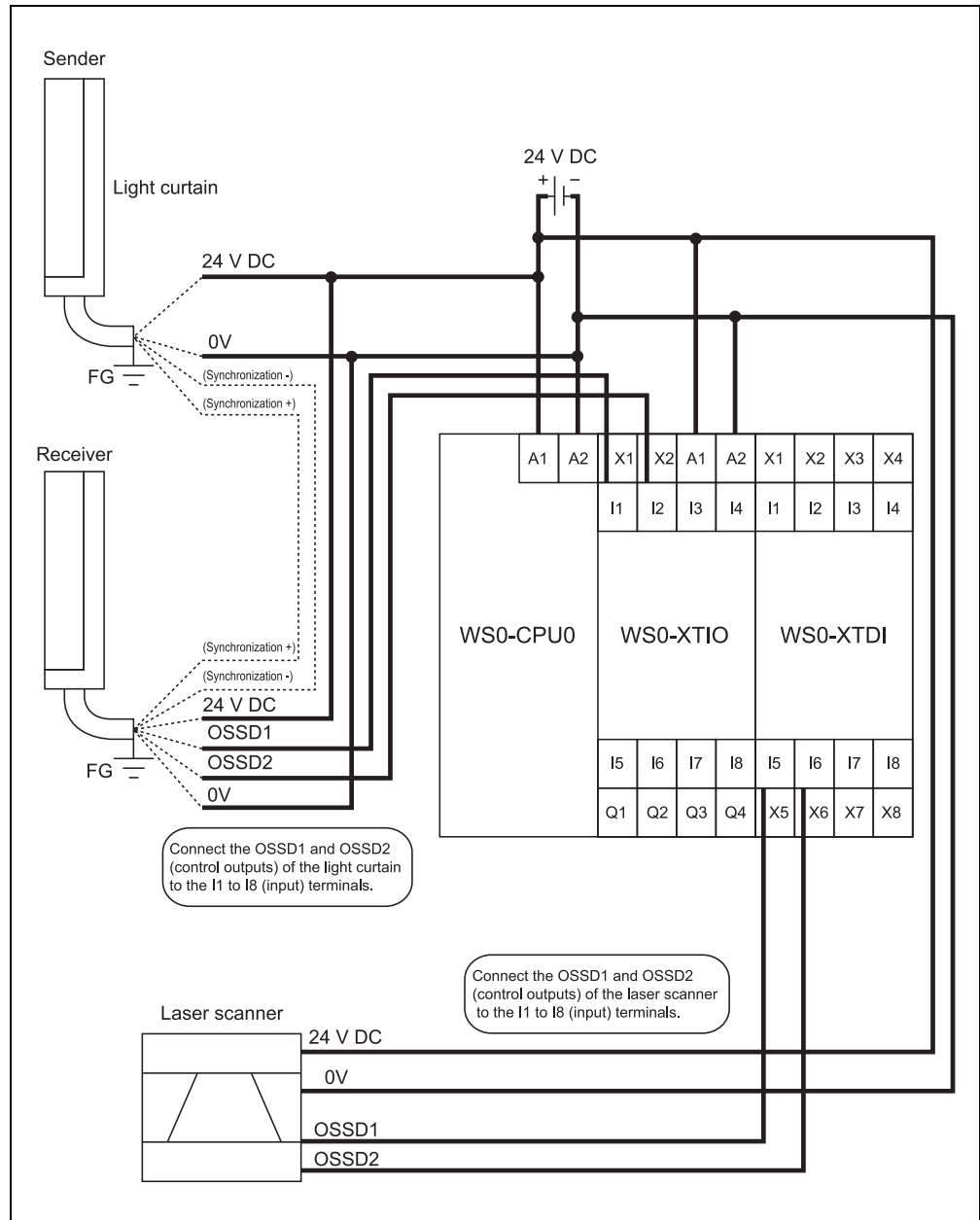

* The light curtain is connected to the WS0-XTIO and the laser scanner is connected to the WS0-XTDI in the above example. Both elements can be connected to either module.

(4) Wiring of contactors

Connect a contactor to the MELSEC-WS safety controller as shown below.

Figure 42:
Wiring example of contactor

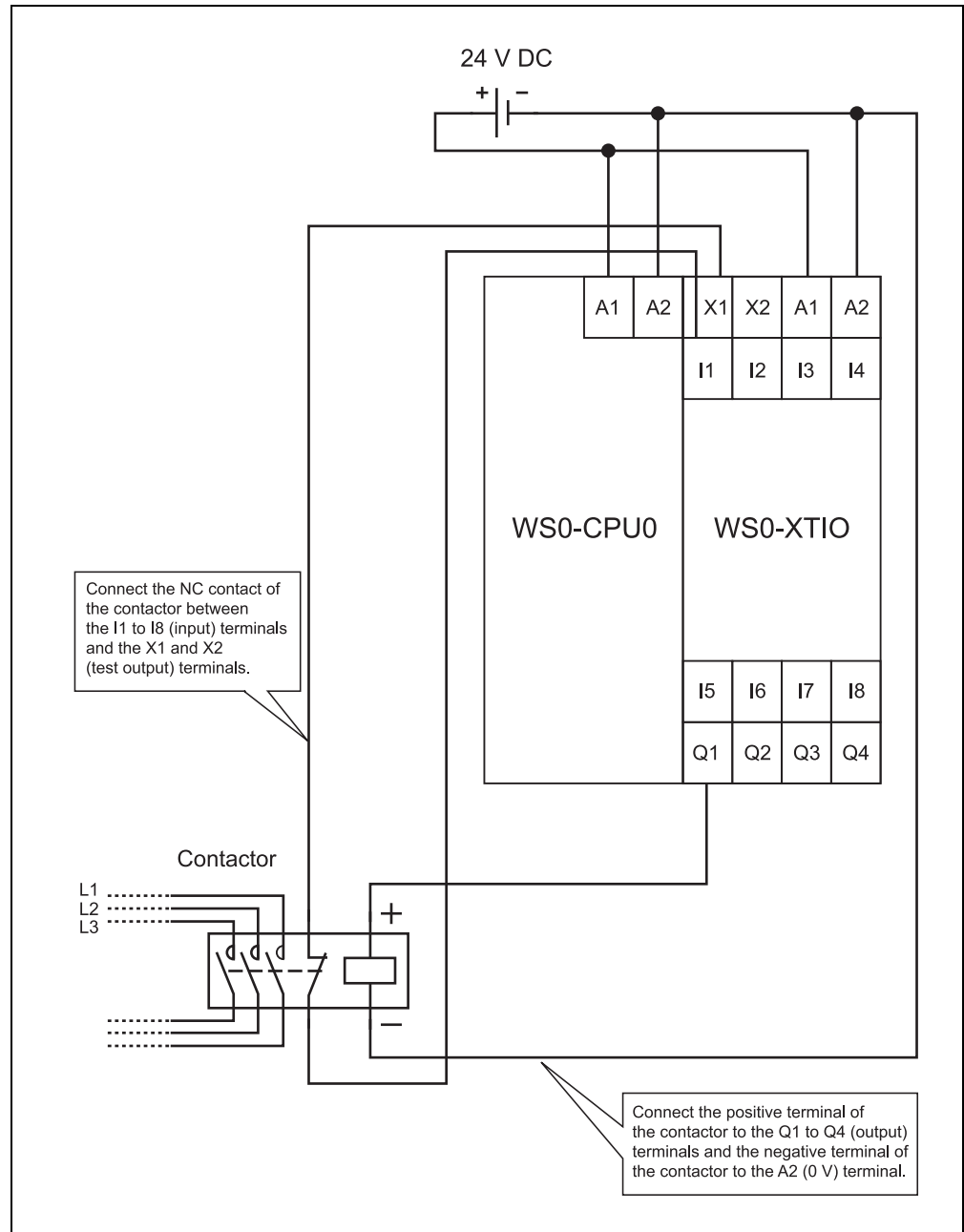

(5) Wiring of contactors (Category 3/4)

The system meets the requirements of Category 3 even when the output of WS0-XTIO (Q1 to Q4) is a single-channel structure. When the output is a dual-channel structure, the system meets the requirements of Category 4. Properly connect the wires so that two wires will not simultaneously short out or break.

Figure 43:
Wiring example of contactor
(Category 3/4)

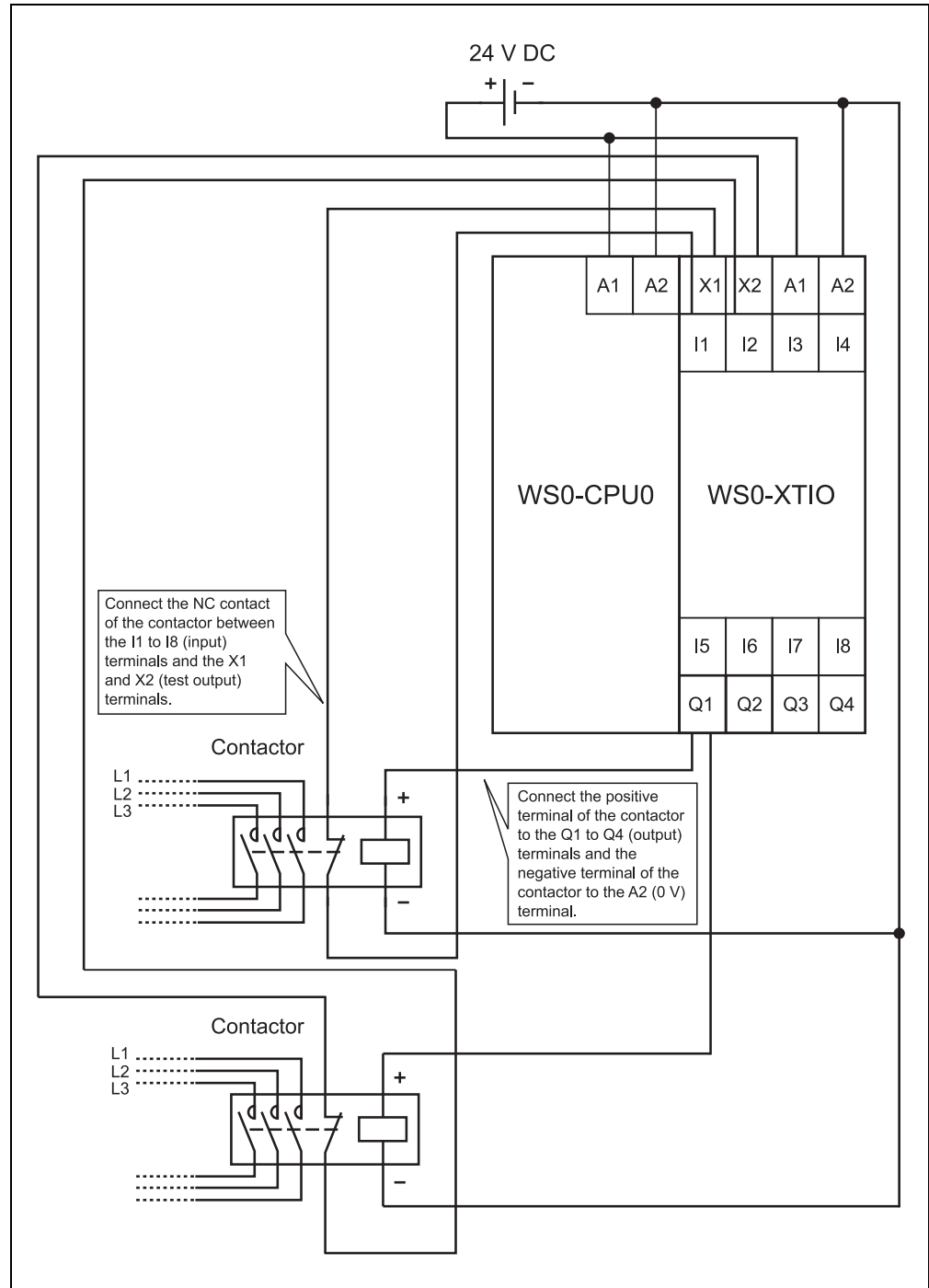

<Application example>

Simultaneous protection from danger (Use of a laser scanner)

Figure 44:
Application example

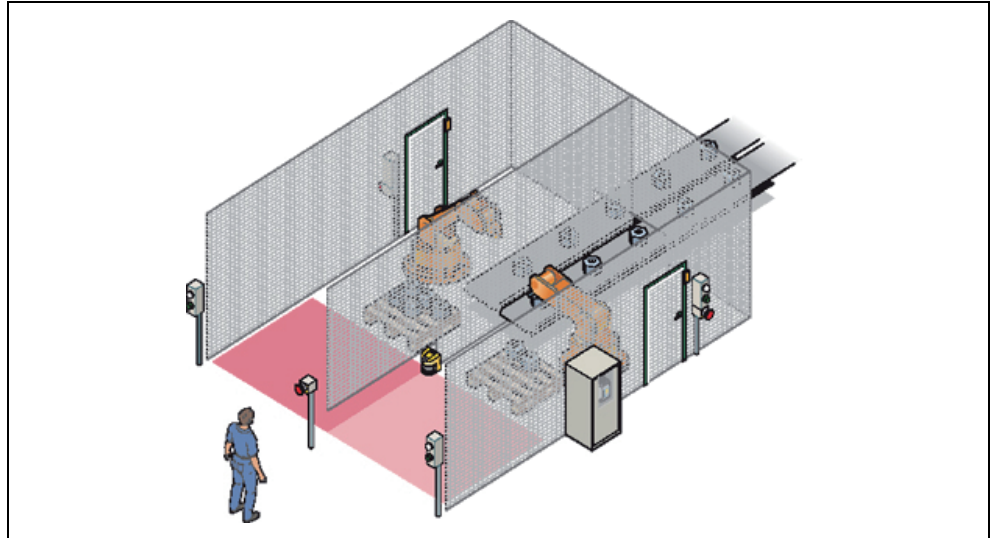

[Function]

Two independent robots are protected with one laser scanner (S3000).

An operator can access the dangerous area through the protective area or the side gates.

When the operator opens the side gate or crossing the laser-protected area, the robots stop their operation. Both robots stop when any one of the emergency stop switches is activated.

Reset the safety device after activation.

[Safety]

This system meets the performance level d in accordance with EN/ISO13849-1.

(1) Wiring

Figure 45:
Wiring of an application
example

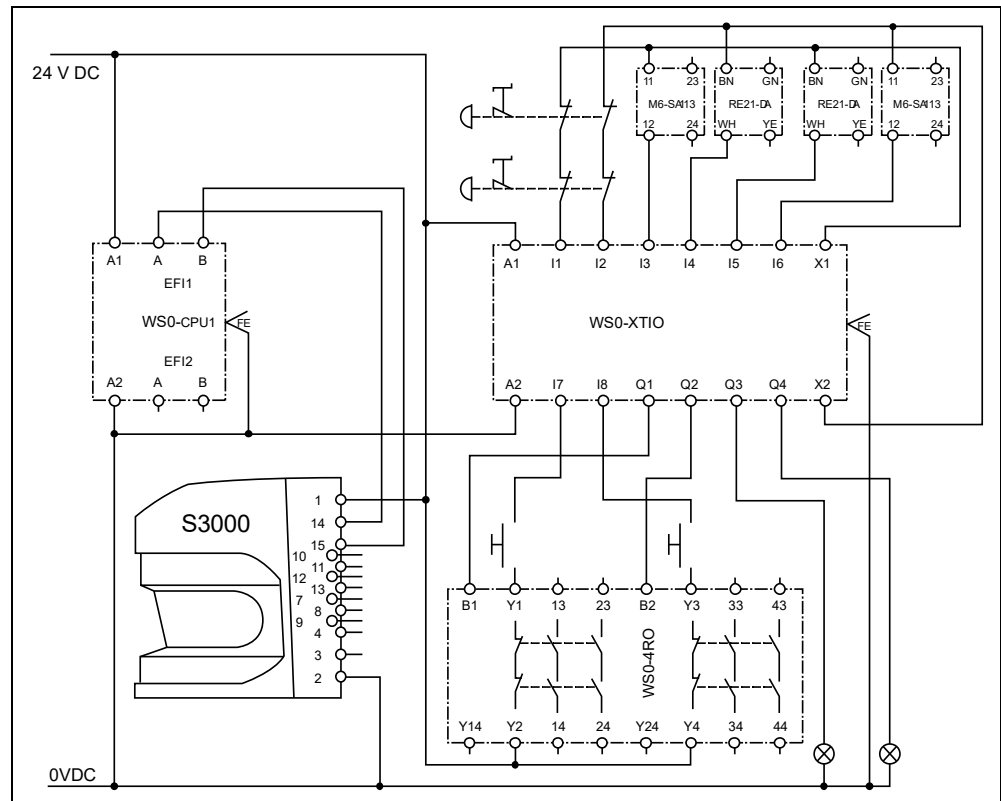

* The WS0-4RO cannot be used alone. The WS0-4RO performs the ON/OFF control via the WS0-XTIO. Connect the output terminals (Q1 to Q4) of the WS0-XTIO to the input terminals (B1 and B2).

(2) Configuration in the Setting and Monitoring Tool

a) Hardware configuration

Figure 46: Hardware configuration of an application example

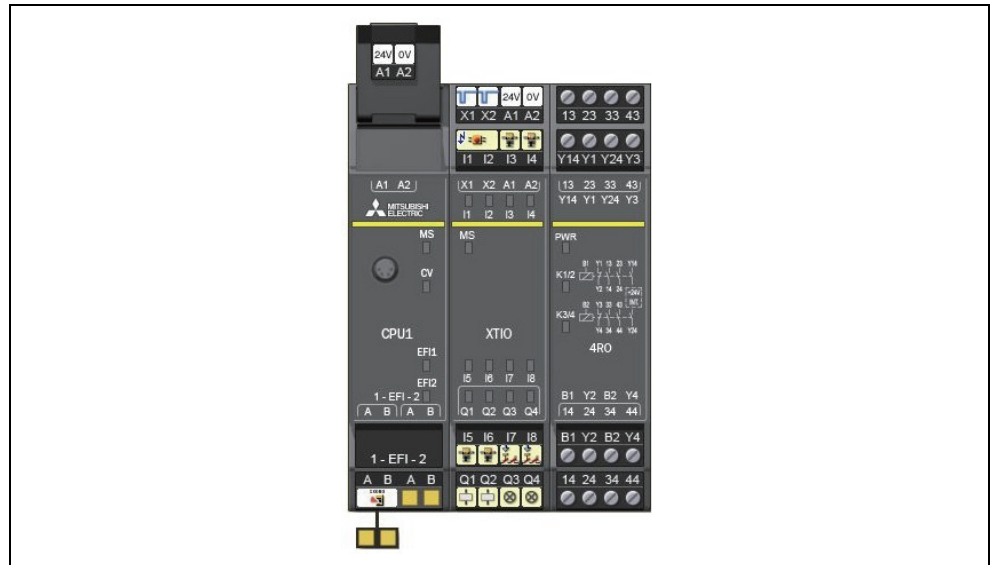

b) Logic

Figure 47: Logic of an application example

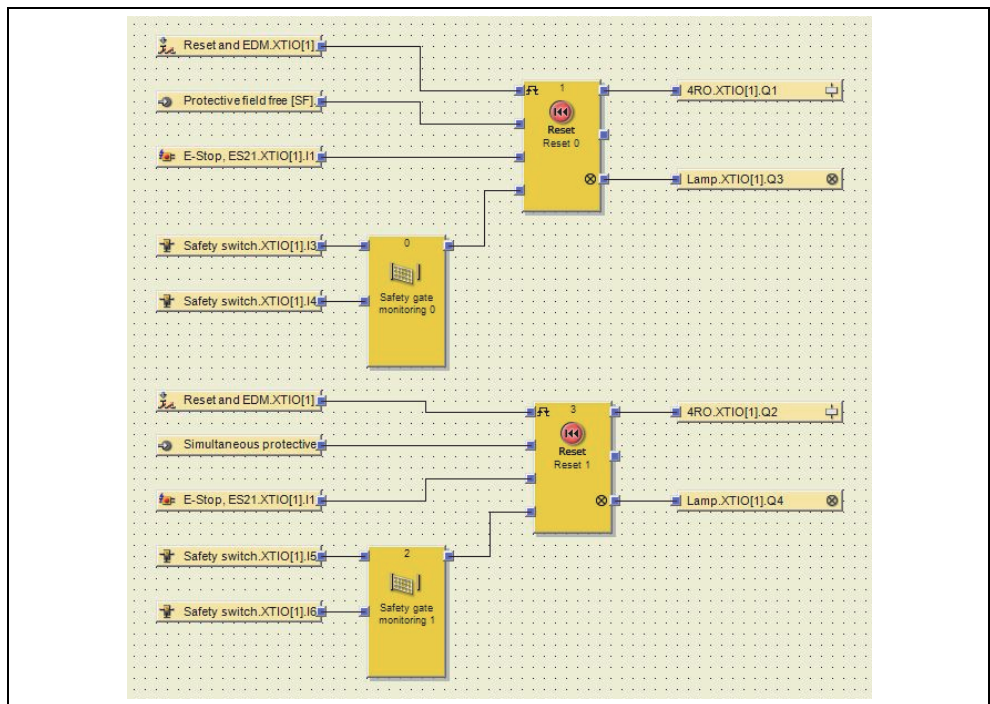

14.5 Troubleshooting

This section describes errors that may occur during system operation, how to locate the errors, and measures against the errors.

Note Check the LEDs of the module during troubleshooting.

14.5.1 Basics of troubleshooting

In order to increase the reliability of the system, resuming the system operation promptly after correcting a problem is one of the important factors as well as using reliable devices.

To promptly start up the system, the trouble cause must be located and eliminated correctly.

The basic three points to be followed in the troubleshooting are as follows.

- (1) Visual inspection
Visually check the following.
 - 1) Behavior of the safety controller and other connected devices
 - 2) Applicability of the power supply
 - 3) States of input and output devices
 - 4) Installation states of the CPU module and safety I/O modules
 - 5) Wiring (Power cable and I/O lines)
 - 6) Display status of all indicators (such as MS LED and CV LED)After checking 1) through 6), connect the Setting and Monitoring Tool and monitor the operating status and logic processing of the MELSEC-WS safety controller.
- (2) Error checking
Check how the error status changes by operating the following to the safety controller.
 - 1) Turn on or off the power supplied to the memory plug.
- (3) Narrowing down the scope for identifying trouble cause
Estimate the troubled part based on the check results of the items (1) and (2) above.
 - 1) MELSEC-WS safety controller or external devices
 - 2) CPU module or others
 - 3) Configuration

14.5.2 Troubleshooting flowchart (for CPU module)

This section describes how to identify errors and measures to eliminate the errors.

(1) Troubleshooting flowchart

The following shows the error description according to the types of events.

Figure 48:
Troubleshooting flowchart
for CPU module

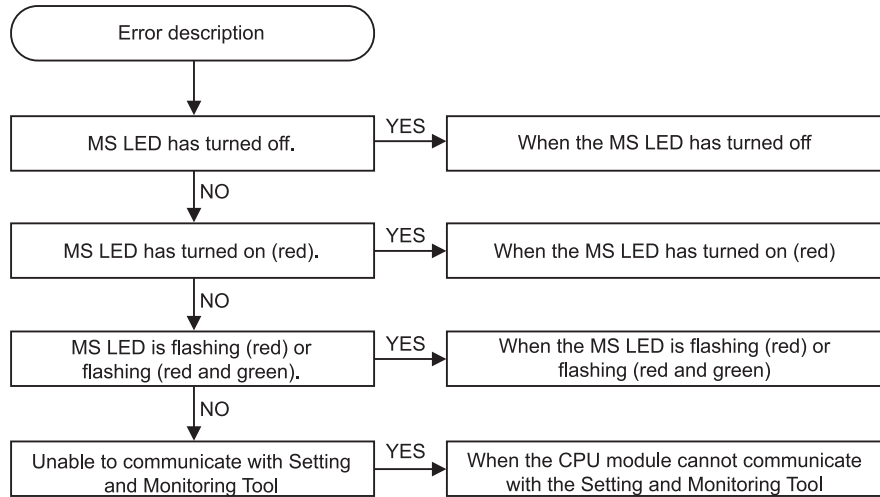

(2) When the MS LED has turned off

Refer to the following flowchart when the MS LED of the CPU module has turned off at power-on or during operation of the MELSEC-WS safety controller.

Figure 49:
Flowchart when the MS
LED has turned off

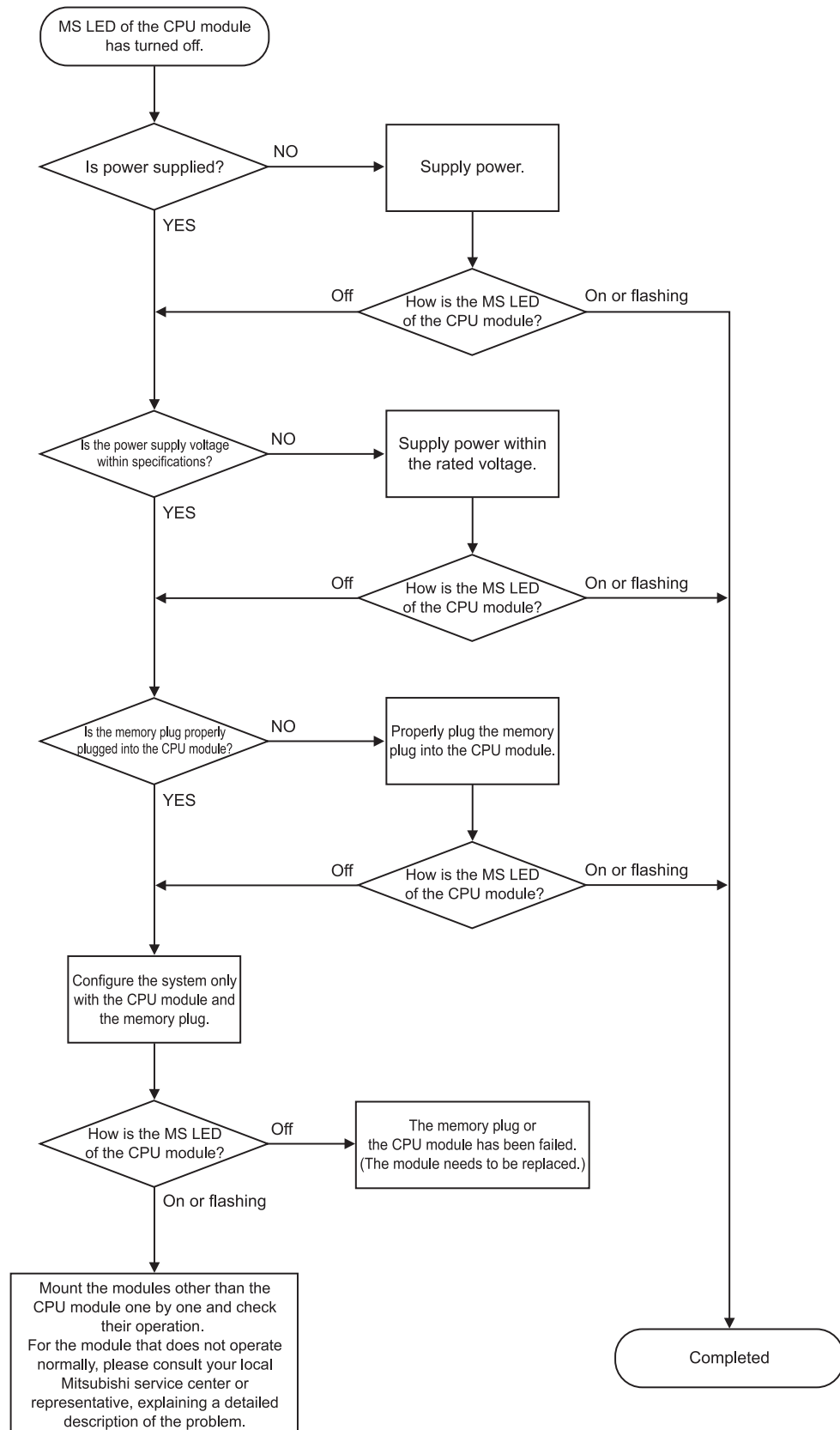

(3) When the MS LED has turned on (red)

Refer to the following flowchart when the MS LED of the CPU module has turned on (red) at power-on or during operation of the MELSEC-WS safety controller.

Figure 50:
Flowchart when the MS LED has turned on (red)

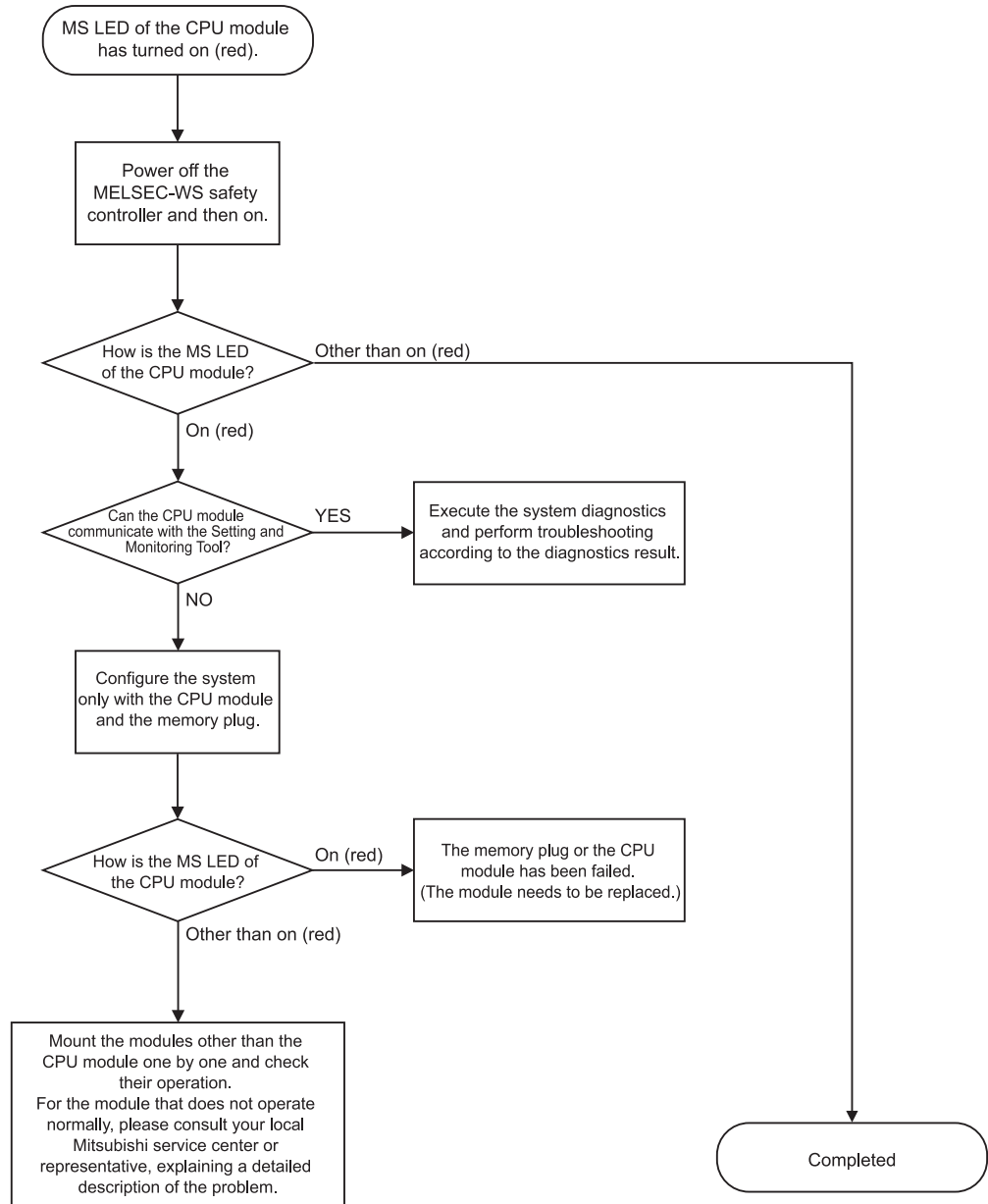

- (4) When the MS LED is flashing (red) or flashing (red and green)
Refer to the following flowchart when the MS LED of the CPU module is flashing (red) or flashing (red and green) at power-on or during operation of the MELSEC-WS safety controller.

Figure 51:
Flowchart when the MS LED is flashing (red) or flashing (red and green)

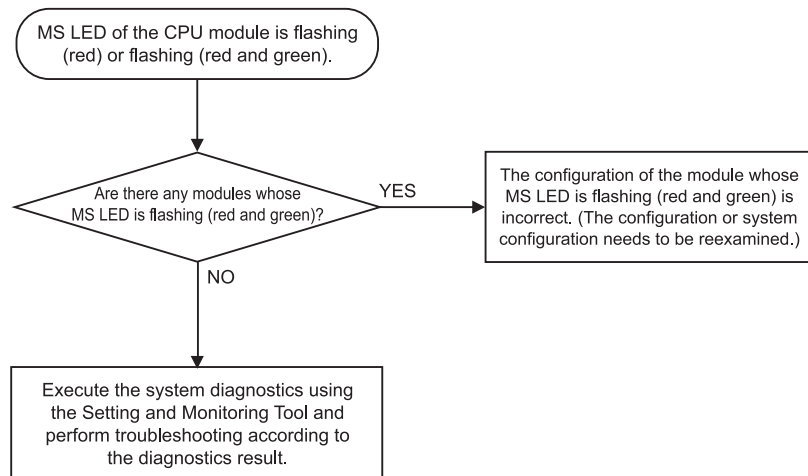

(5) When the CPU module cannot communicate with Setting and Monitoring Tool

Refer to the following flowchart when communication with a peripheral device is disabled when connecting the CPU module with Setting and Monitoring Tool.

Figure 52:
Flowchart when the CPU module cannot communicate with Setting and Monitoring Tool

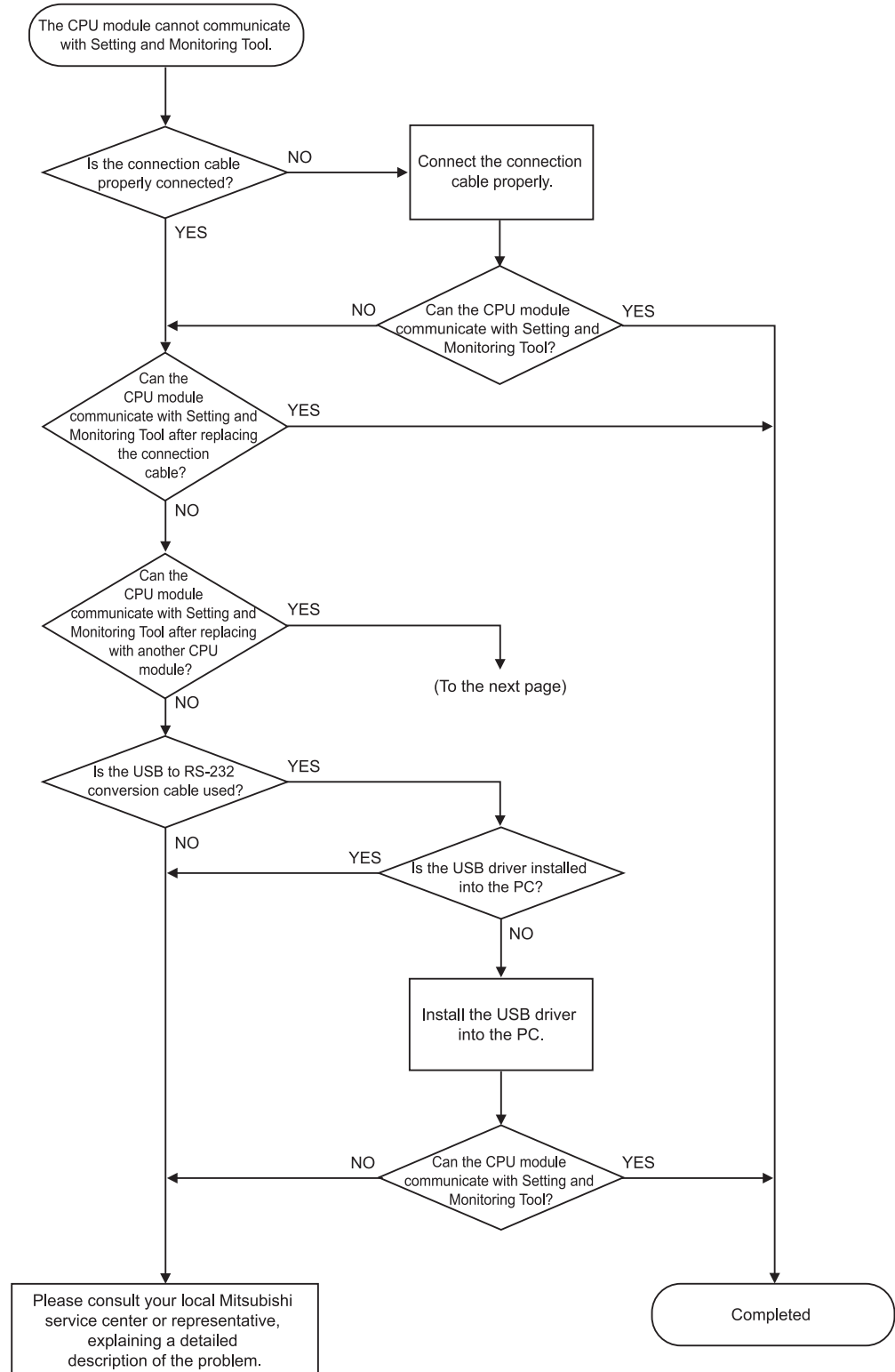

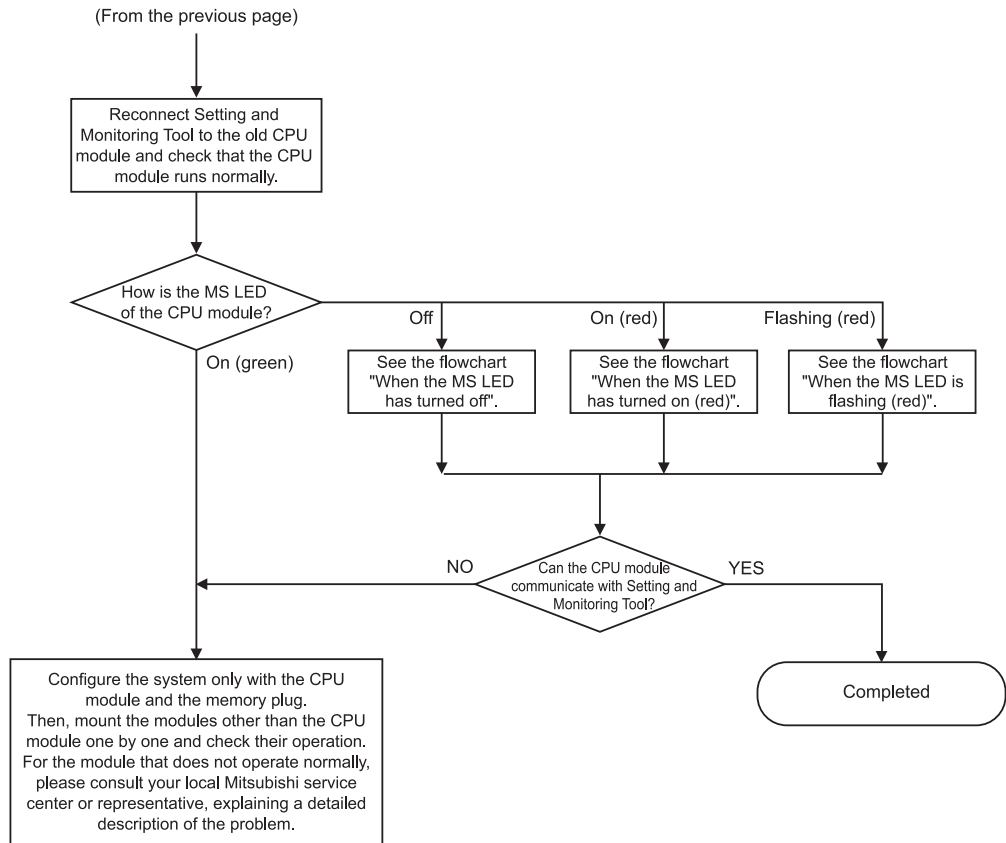

14.5.3 Troubleshooting flowchart (for safety I/O module)

This section describes how to identify errors and measures to eliminate the errors.

(1) Troubleshooting flowchart

The following shows the error description according to the types of events.

Figure 53:
Troubleshooting flowchart
for safety I/O module

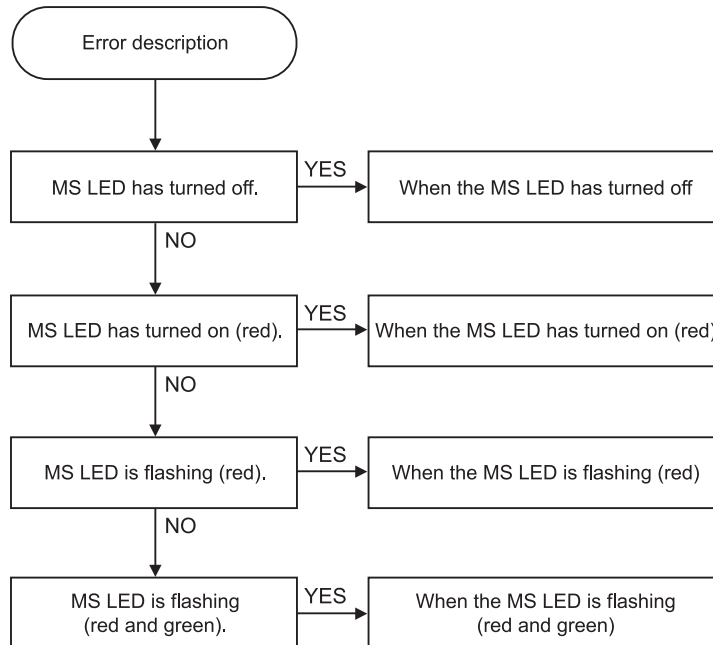

(2) When the MS LED has turned off

Refer to the following flowchart when the MS LED of the safety I/O module has turned off at power-on or during operation of the MELSEC-WS safety controller.

Figure 54:
Flowchart when the MS
LED has turned off

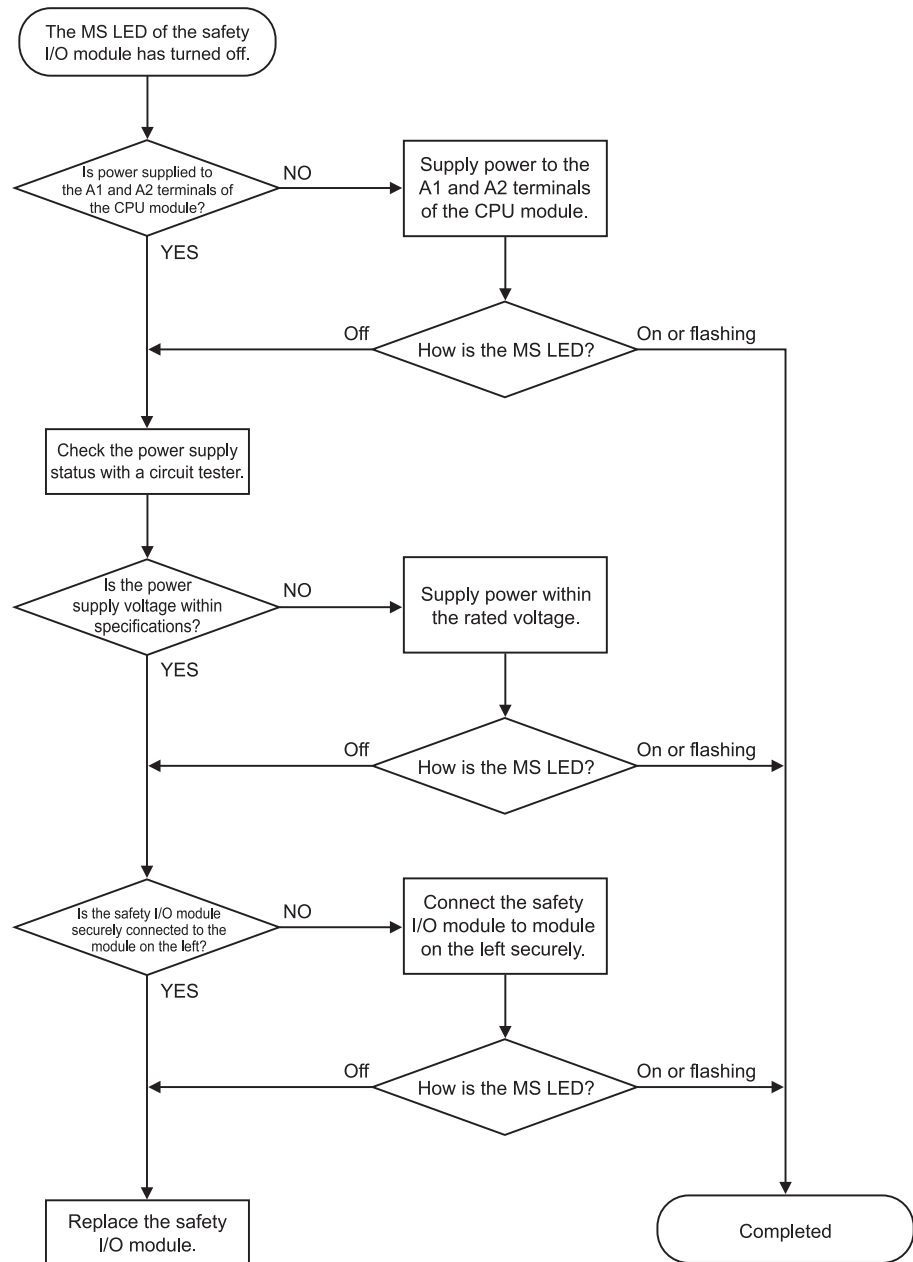

(3) When the MS LED has turned on (red)
 Refer to the following flowchart when the MS LED of the safety I/O module has turned on (red) at power-on or during operation of the MELSEC-WS safety controller.

Figure 55:
 Flowchart when the MS LED has turned on (red)

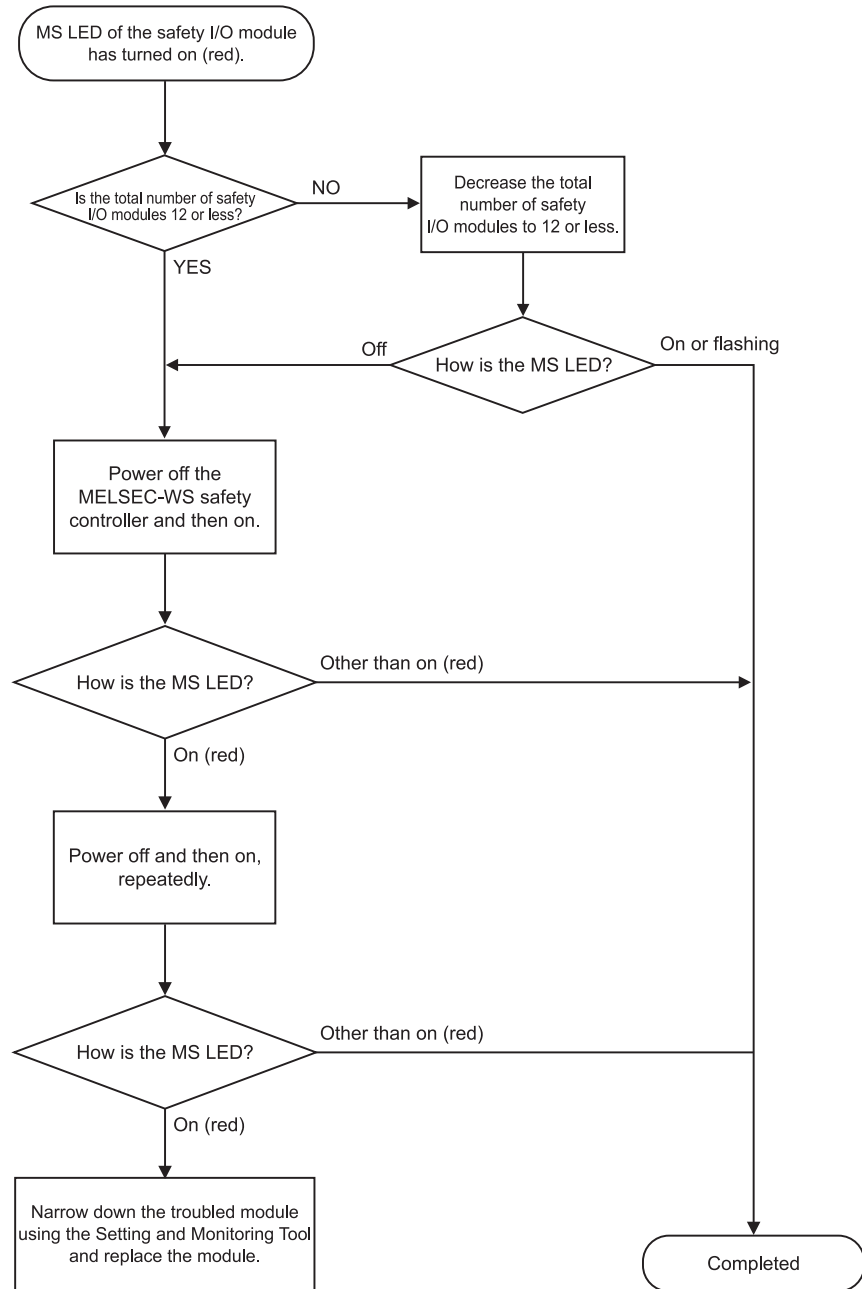

(4) When the MS LED is flashing (red)

Refer to the following flowchart when the MS LED of the safety I/O module is flashing (red) at power-on or during operation of the MELSEC-WS safety controller.

(a) For safety I/O modules (firmware V1.xx.0)

Figure 56:
Flowchart when the MS
LED is flashing (red)
(firmware V1.xx.0)

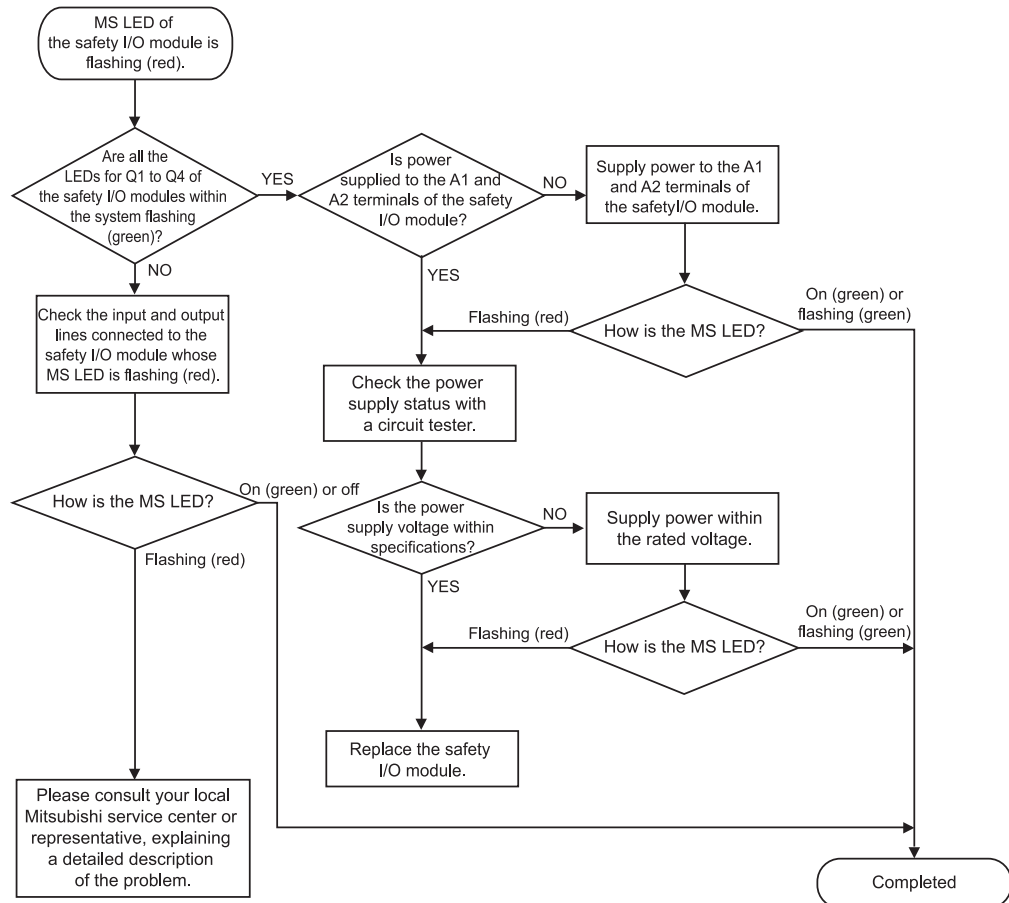

(b) For safety I/O modules (firmware V2.00.0 or later)

Figure 57:
Flowchart when the MS
LED is flashing (red)
(firmware V2.00.0 or later)

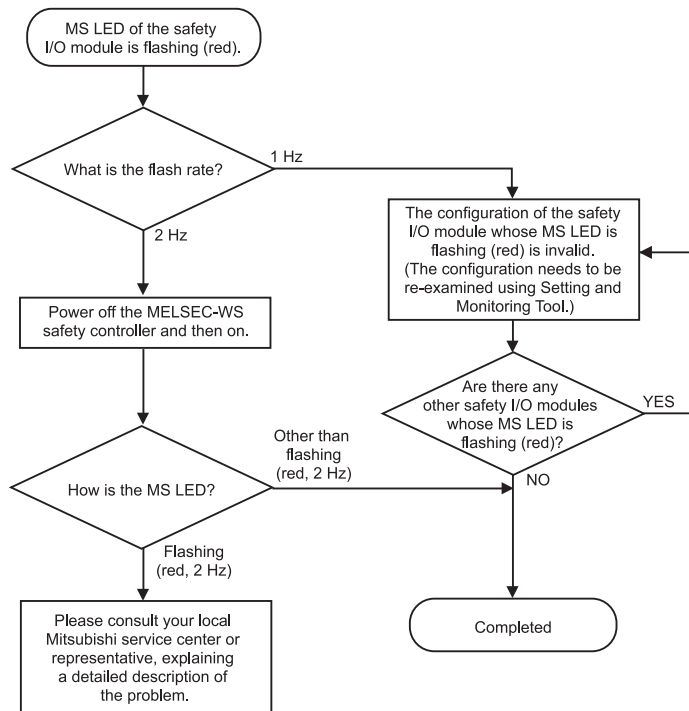

(5) When the MS LED is flashing (red and green)

Refer to the following flowchart when the MS LED of the safety I/O module is flashing (red and green) at power-on or during operation of the MELSEC-WS safety controller.

(a) For safety I/O modules (firmware V1.xx.0)

Figure 58:
Flowchart when the MS
LED is flashing (red and
green) (firmware V1.xx.0)

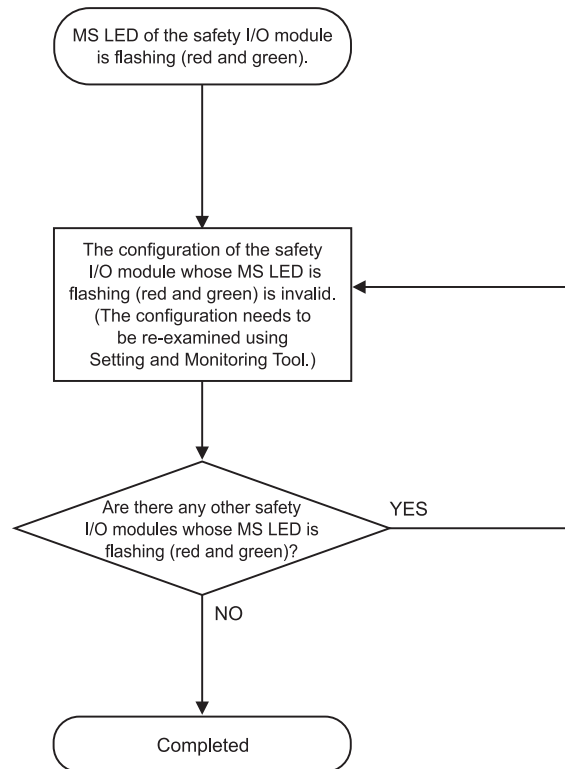

(b) For safety I/O modules (firmware V2.00.0 or later)

Figure 59:
Flowchart when the MS
LED is flashing (red and
green) (firmware V2.00.0 or
later)

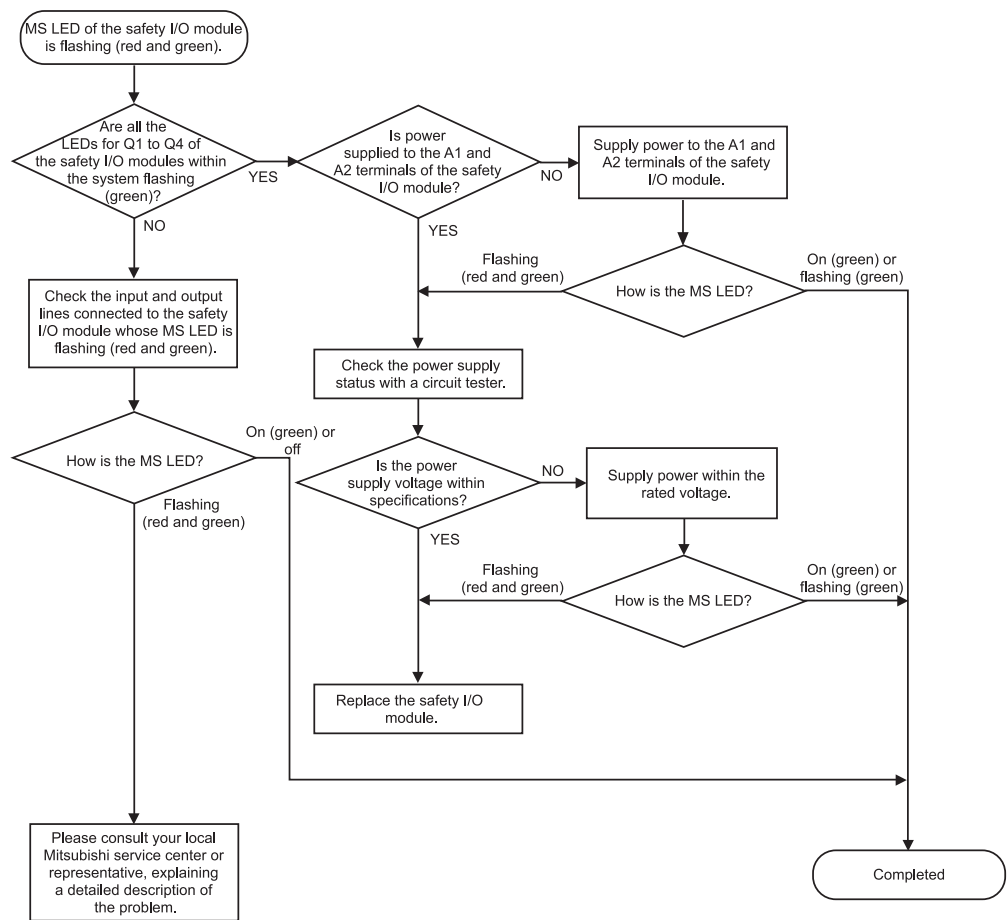

14.5.4 Troubleshooting flowchart (for safety relay output module)

This section describes how to identify errors and measures to eliminate the errors.

(1) Troubleshooting flowchart

The following shows the error description according to the types of events.

Figure 60:
Troubleshooting flowchart
for safety output relay
module

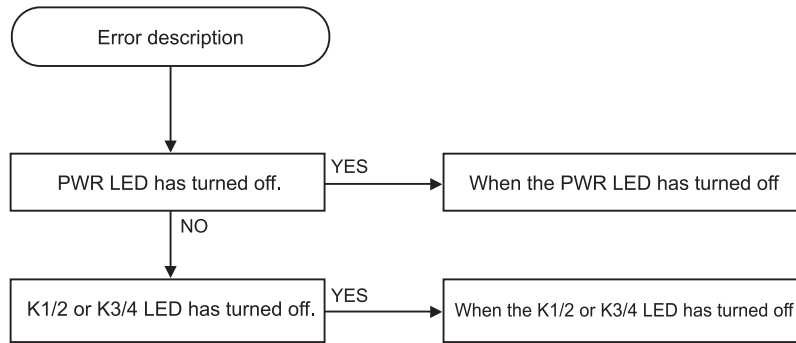

(2) When the PWR LED has turned off
Refer to the following flowchart when the PWR LED of the safety relay output module has turned off at power-on or during operation of the MELSEC-WS safety controller.

Figure 61:
Flowchart when the PWR LED has turned off

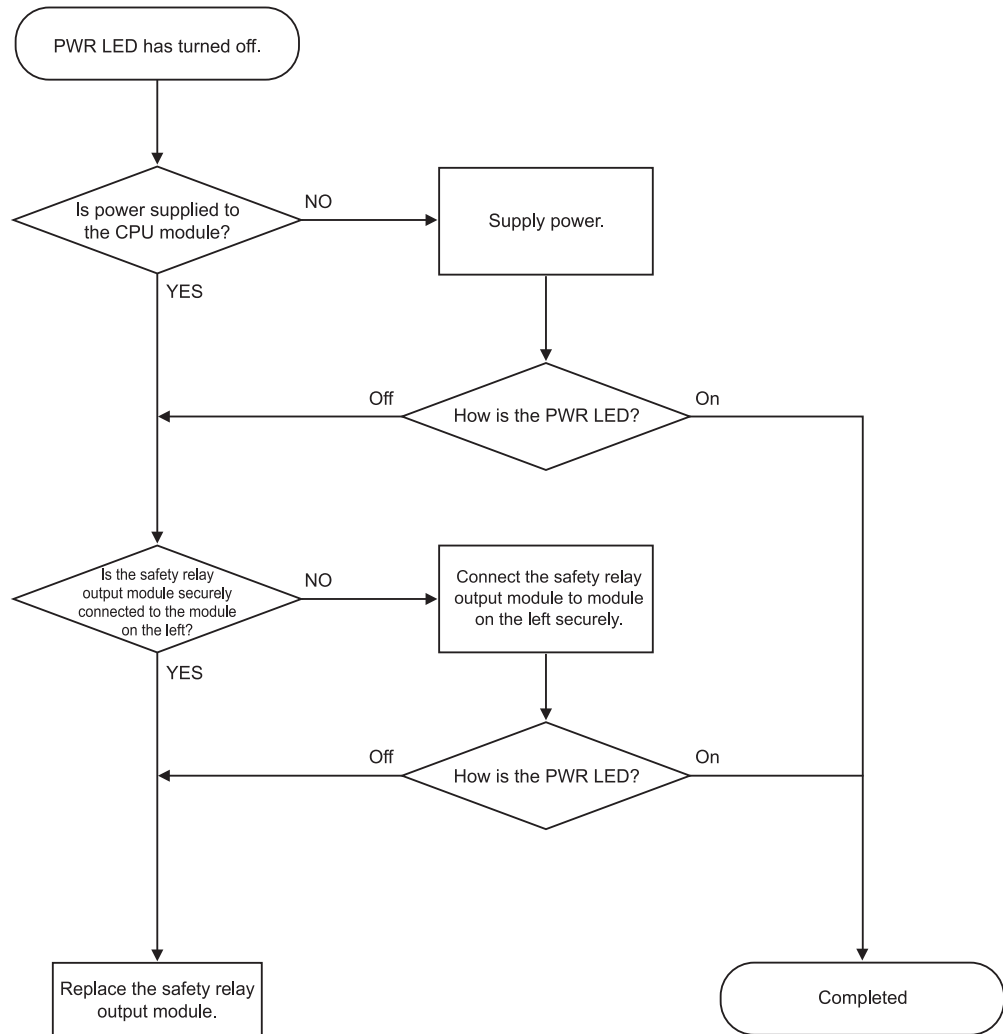

(3) When the K1/2 or K3/4 LED has turned off

Refer to the following flowchart when the K1/2 or K3/4 LED of the safety relay output module has turned off at power-on or during operation of the MELSEC-WS safety controller.

Figure 62:
Flowchart when the K1/2 or
K3/4 LED has turned off

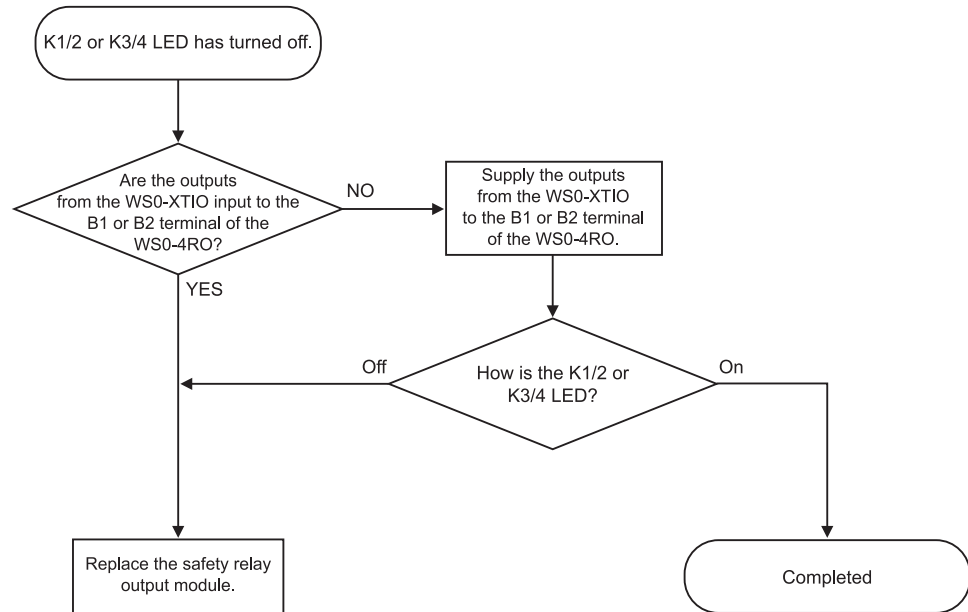

14.5.5 Troubleshooting (for terminal wiring)

This section describes common errors and their causes and actions.

For the information of terminal wiring including wire ferrule specifications, refer to Section 7.1.

Error	Cause	Action
The connected wire ferrule is accidentally disconnected.	A wire ferrule or a crimping tool other than ones specified in this manual was used.	Use the wire ferrules or the crimping tool specified in this manual.
	The wire ferrule was not crimped properly.	Check how to use the crimping tool. PHOENIX CONTACT GmbH & Co. KG www.phoenixcontact.com
The connected wire ferrule cannot be removed or difficult to be removed.	A wire ferrule other than ones specified in this manual was used.	Use the wire ferrules specified in this manual.
	The wire ferrule was not crimped properly.	Check how to use the crimping tool. PHOENIX CONTACT GmbH & Co. KG www.phoenixcontact.com
	The outer dimensions of the crimped wire ferrule is exceeding the maximum dimensions.	Use an appropriate combination of wire ferrule size and wire size.
	The shape of the removal tool is not appropriate.	Use the reference product of removal tool.

Table 67:
Troubleshooting (for wire ferrules)

14.6 Example for the calculation of the response time of Flexi Line

Calculation of the response time for a MELSEC-WS safety controller:

Figure 63:
Response times within a
MELSEC-WS safety
controller

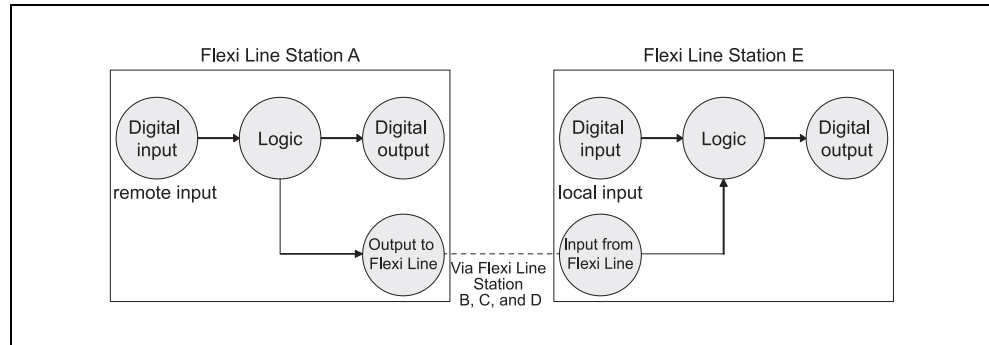

Flexi Line Station A

Logic execution time = 4ms

Flexi Line update rate = 2ms

Occurrence	In1: Digital inputs	
General	Tactile sensor	0ms
General	Input processing time	6.5ms
When On/Off filter	8.0ms	–
When X1 ... X8 is connected at the test output...	–	–
	Total In1	6.5ms

Occurrence	Out2: Output to EFI device	
General	Response time of the actuator (Robot response time)	40.0ms
When Flexi Line data are used	logic execution time	4.0ms
General	Output processing time	4.5ms
	Total Output	56.0ms
Occurrence	Output : Output to Flexi Line	
Output to Flexi Line	–	–
	Total Output	0ms

Evaluation1			
1. Inputs	Response time of the considered input in the signal path	In1	6.5ms
2. Logic	Response time of the logic	2 × logic execution time	8.0ms
		Delay through logic application	–
3. Outputs	Response time of the considered output in local	out2	56.0ms
Total response time (remote input to local output)			70.5ms
Evaluation2			
1. Inputs	Response time of the considered input in the signal path	In1	6.5ms
2. Logic	Response time of the logic	2 × logic execution time	8.0ms
		Delay through logic application	–
3. Outputs	Response time of the Flexi Line output	Out2	0ms
Total response time (Response time of the Flexi Line output)			14.5ms

Flexi Line Station E

Logic execution time = 8ms

Occurrence	Input: Input from Flexi Line		Occurrence	Out1: Digital outputs	
Flexi Line connections through 4 stations	Response time in the station with the remote input	14.5ms	General	Response time of the actuator (Robot response time)	40.0ms
	$4 \times (10\text{ms} + 2 \times 2\text{ms})$	56.0ms	General	Output processing time	4.5ms
	Total Input	70.5ms		Total Out1	44.5ms

Evaluation			
1. Inputs	Response time of the considered input in remote input	Input	70.5ms
2. Logic	Response time of the logic	$2 \times$ logic execution time	16.0ms
		Delay through logic application	–
3. Outputs	Response time of the considered output in path 2	Out1	44.5ms
Total response time (remote input to local output)			131.0ms

Table 68:

Example for the calculation of the response time of a remote input in a MELSEC-WS safety controller

14.7 SICK contact

More representatives and agencies in all major industrial nations at www.sick.com

Australia

Phone +61 3 9497 4100
1800 33 48 02 – tollfree
E-Mail sales@sick.com.au

Belgium/Luxembourg

Phone +32 (0)2 466 55 66
E-Mail info@sick.be

Brasil

Phone +55 11 3215-4900
E-Mail sac@sick.com.br

Ceská Republika

Phone +420 2 57 91 18 50
E-Mail sick@sick.cz

China

Phone +852-2763 6966
E-Mail ghk@sick.com.hk

Danmark

Phone +45 45 82 64 00
E-Mail sick@sick.dk

Deutschland

Phone +49 211 5301-260
E-Mail info@sick.de

España

Phone +34 93 480 31 00
E-Mail info@sick.es

France

Phone +33 1 64 62 35 00
E-Mail info@sick.fr

Great Britain

Phone +44 (0)1727 831121
E-Mail info@sick.co.uk

India

Phone +91-22-4033 8333
E-Mail info@sick-india.com

Israel

Phone +972-4-9990590
E-Mail info@sick-sensors.com

Italia

Phone +39 02 27 43 41
E-Mail info@sick.it

Japan

Phone +81 (0)3 3358 1341
E-Mail support@sick.jp

Nederlands

Phone +31 (0)30 229 25 44
E-Mail info@sick.nl

Norge

Phone +47 67 81 50 00
E-Mail austefjord@sick.no

Österreich

Phone +43 (0)22 36 62 28 8-0
E-Mail office@sick.at

Polska

Phone +48 22 837 40 50
E-Mail info@sick.pl

Republic of Korea

Phone +82-2 786 6321/4
E-Mail kang@sickkorea.net

Republika Slovenija

Phone +386 (0)1-47 69 990
E-Mail office@sick.si

Romania

Phone +40356171120
E-Mail office@sick.ro

Russia

Phone +7-495-775-05-34
E-Mail info@sick-automation.ru

Schweiz

Phone +41 41 619 29 39
E-Mail contact@sick.ch

Singapore

Phone +65 6744 3732
E-Mail admin@sicksgp.com.sg

Suomi

Phone +358-9-25 15 800
E-Mail sick@sick.fi

Sverige

Phone +46 10 110 10 00
E-Mail info@sick.se

Taiwan

Phone +886 2 2375 -6288
E-Mail sales@sick.com.tw

Türkiye

Phone +90 216 587 74 00
E-Mail info@sick.com.tr

United Arab Emirates

Phone + 971 4 8865 878
E-Mail info@sick.ae

USA/Canada/México

Phone +1(952) 941- 6780
1800-325-7425 – tollfree
E-Mail info@sickusa.com

WARRANTY

1. Limited Warranty and Product Support.

- a. Mitsubishi Electric Company ("MELCO") warrants that for a period of eighteen (18) months after date of delivery from the point of manufacture or one year from date of Customer's purchase, whichever is less, Mitsubishi Safety Controller (the "Products") will be free from defects in material and workmanship.
- b. At MELCO's option, for those Products MELCO determines are not as warranted, MELCO shall either repair or replace them or issue a credit or return the purchase price paid for them.
- c. For this warranty to apply:
 - (1) Customer shall give MELCO (i) notice of a warranty claim to MELCO and the authorized dealer or distributor from whom the Products were purchased, (ii) the notice shall describe in reasonable details the warranty problem, (iii) the notice shall be provided promptly and in no event later than thirty (30) days after the Customer knows or has reason to believe that Products are not as warranted, and (iv) in any event, the notice must be given within the warranty period;
 - (2) Customer shall cooperate with MELCO and MELCO's representatives in MELCO's investigation of the warranty claim, including preserving evidence of the claim and its causes, meaningfully responding to MELCO's questions and investigation of the problem, grant MELCO access to witnesses, personnel, documents, physical evidence and records concerning the warranty problem, and allow MELCO to examine and test the Products in question offsite or at the premises where they are installed or used; and
 - (3) If MELCO requests, Customer shall remove Products it claims are defective and ship them to MELCO or MELCO's authorized representative for examination and, if found defective, for repair or replacement. The costs of removal, shipment to and from MELCO's designated examination point, and reinstallation of repaired or replaced Products shall be at Customer's expense.
 - (4) If Customer requests and MELCO agrees to effect repairs onsite at any domestic or overseas location, the Customer will pay for the costs of sending repair personnel and shipping parts. MELCO is not responsible for any re-commissioning, maintenance, or testing on-site that involves repairs or replacing of the Products.
- d. Repairs of Products located outside of Japan are accepted by MELCO's local authorized service facility centers ("FA Centers"). Terms and conditions on which each FA Center offers repair services for Products that are out of warranty or not covered by MELCO's limited warranty may vary.
- e. Subject to availability of spare parts, MELCO will offer Product repair services for (4) years after each Product model or line is discontinued, at MELCO's or its FA Centers' rates and charges and standard terms in effect at the time of repair. MELCO usually produces and retains sufficient spare parts for repairs of its Products for a period of four (4) years after production is discontinued.
- f. MELCO generally announces discontinuation of Products through MELCO's Technical Bulletins. Products discontinued and repair parts for them may not be available after their production is discontinued.

2. Limits of Warranties.

- a. MELCO does not warrant or guarantee the design, specify, manufacture, construction or installation of the materials, construction criteria, functionality, use, properties or other characteristics of the equipment, systems, or production lines into which the Products may be incorporated, including any safety, fail-safe and shut down systems using the Products.
- b. MELCO is not responsible for determining the suitability of the Products for their intended purpose and use, including determining if the Products provide appropriate safety margins and redundancies for the applications, equipment or systems into which they are incorporated.
- c. Customer acknowledges that qualified and experienced personnel are required to determine the suitability, application, design, construction and proper installation and integration of the Products. MELCO does not supply such personnel.
- d. MELCO is not responsible for designing and conducting tests to determine that the Product functions appropriately and meets application standards and requirements as installed or incorporated into the end-user's equipment, production lines or systems.
- e. MELCO does not warrant any Product:
 - (1) repaired or altered by persons other than MELCO or its authorized engineers or FA Centers;
 - (2) subjected to negligence, carelessness, accident, misuse, or damage;
 - (3) improperly stored, handled, installed or maintained;
 - (4) integrated or used in connection with improperly designed, incompatible or defective hardware or software;
 - (5) that fails because consumable parts such as relay, batteries, backlights, or fuses were not tested, serviced or replaced;
 - (6) operated or used with equipment, production lines or systems that do not meet applicable and commensurate legal, safety and industry-accepted standards;
 - (7) operated or used in abnormal applications;
 - (8) installed, operated or used in contravention of instructions, precautions or warnings contained in MELCO's user, instruction and/or safety manuals, technical bulletins and guidelines for the Products;
 - (9) used with obsolete technologies or technologies not fully tested and widely accepted and in use at the time of the Product's manufacture;
 - (10) subjected to excessive heat or moisture, abnormal voltages, shock, excessive vibration, physical damage or other improper environment; or
 - (11) damaged or malfunctioning due to Acts of God, fires, acts of vandals, criminals or terrorists, communication or power failures, or any other cause or failure that results from circumstances beyond MELCO's control.
- f. All Product information and specifications contained on MELCO's website and in catalogs, manuals, or technical information materials provided by MELCO are subject to change without prior notice.
- g. The Product information and statements contained on MELCO's website and in catalogs, manuals, technical bulletins or other materials provided by MELCO are provided as a guide for Customer's use. They do not constitute warranties and are not incorporated in the contract of sale for the Products.

- h. These terms and conditions constitute the entire agreement between Customer and MELCO with respect to warranties, remedies and damages and supersede any other understandings, whether written or oral, between the parties. Customer expressly acknowledges that any representations or statements made by MELCO or others concerning the Products outside these terms are not part of the basis of the bargain between the parties and are not factored into the pricing of the Products.
- i. THE WARRANTIES AND REMEDIES SET FORTH IN THESE TERMS ARE THE EXCLUSIVE AND ONLY WARRANTIES AND REMEDIES THAT APPLY TO THE PRODUCTS.
- j. MELCO DISCLAIMS THE IMPLIED WARRANTIES OF MERCHANTABILITY AND FITNESS FOR A PARTICULAR PURPOSE.

3. Limits on Damages.

- a. MELCO'S MAXIMUM CUMULATIVE LIABILITY BASED ON ANY CLAIMS FOR BREACH OF WARRANTY OR CONTRACT, NEGLIGENCE, STRICT TORT LIABILITY OR OTHER THEORIES OF RECOVERY REGARDING THE SALE, REPAIR, REPLACEMENT, DELIVERY, PERFORMANCE, CONDITION, SUITABILITY, COMPLIANCE, OR OTHER ASPECTS OF THE PRODUCTS OR THEIR SALE, INSTALLATION OR USE SHALL BE LIMITED TO THE PRICE PAID FOR PRODUCTS NOT AS WARRANTED.
- b. Although MELCO has obtained the certification for Product's compliance to the international safety standards IEC61508 and ISO13849-1 from TUV Rheinland, this fact does not guarantee that Product will be free from any malfunction or failure. The user of this Product shall comply with any and all applicable safety standard, regulation or law and take appropriate safety measures for the system in which the Product is installed or used and shall take the second or third safety measures other than the Product. MELCO is not liable for damages that could have been prevented by compliance with any applicable safety standard, regulation or law.
- c. MELCO prohibits the use of Products with or in any application involving power plants, trains, railway systems, airplanes, airline operations, other transportation systems, amusement equipments, hospitals, medical care, dialysis and life support facilities or equipment, incineration and fuel devices, handling of nuclear or hazardous materials or chemicals, mining and drilling, and other applications where the level of risk to human life, health or property are elevated.
- d. MELCO SHALL NOT BE LIABLE FOR SPECIAL, INCIDENTAL, CONSEQUENTIAL, INDIRECT OR PUNITIVE DAMAGES, FOR LOSS OF PROFITS, SALES, OR REVENUE, FOR INCREASED LABOR OR OVERHEAD COSTS, FOR DOWNTIME OR LOSS OF PRODUCTION, FOR COST OVERRUNS, OR FOR ENVIRONMENTAL OR POLLUTION DAMAGES OR CLEAN-UP COSTS, WHETHER THE LOSS IS BASED ON CLAIMS FOR BREACH OF CONTRACT OR WARRANTY, VIOLATION OF STATUTE, NEGLIGENCE OR OTHER TORT, STRICT LIABILITY OR OTHERWISE.
- e. In the event that any damages which are asserted against MELCO arising out of or relating to the Products or defects in them, consist of personal injury, wrongful death and/or physical property

damages as well as damages of a pecuniary nature, the disclaimers and limitations contained in these terms shall apply to all three types of damages to the fullest extent permitted by law. If, however, the personal injury, wrongful death and/or physical property damages cannot be disclaimed or limited by law or public policy to the extent provided by these terms, then in any such event the disclaimer of and limitations on pecuniary or economic consequential and incidental damages shall nevertheless be enforceable to the fullest extent allowed by law.

- f. In no event shall any cause of action arising out of breach of warranty or otherwise concerning the Products be brought by Customer more than one year after the cause of action accrues.
- g. Each of the limitations on remedies and damages set forth in these terms is separate and independently enforceable, notwithstanding the unenforceability or failure of essential purpose of any warranty, undertaking, damage limitation, other provision of these terms or other terms comprising the contract of sale between Customer and MELCO.

4. Delivery/Force Majeure.

- a. Any delivery date for the Products acknowledged by MELCO is an estimated and not a promised date. MELCO will make all reasonable efforts to meet the delivery schedule set forth in Customer's order or the purchase contract but shall not be liable for failure to do so.
- b. Products stored at the request of Customer or because Customer refuses or delays shipment shall be at the risk and expense of Customer.
- c. MELCO shall not be liable for any damage to or loss of the Products or any delay in or failure to deliver, service, repair or replace the Products arising from shortage of raw materials, failure of suppliers to make timely delivery, labor difficulties of any kind, earthquake, fire, windstorm, flood, theft, criminal or terrorist acts, war, embargoes, governmental acts or rulings, loss or damage or delays in carriage, acts of God, vandals or any other circumstances reasonably beyond MELCO's control.

5. Choice of Law/Jurisdiction.

These terms and any agreement or contract between Customer and MELCO shall be governed by the laws of the State of New York without regard to conflicts of laws. To the extent any action or dispute is not arbitrated, the parties consent to the exclusive jurisdiction and venue of the federal and state courts located in the Southern District of the State of New York. Any judgment there obtained may be enforced in any court of competent jurisdiction.

6. Arbitration.

Any controversy or claim arising out of, or relating to or in connection with the Products, their sale or use or these terms, shall be settled by arbitration conducted in accordance with the Center for Public Resources (CPR) Rules for Non-Administered Arbitration of International Disputes, by a sole arbitrator chosen from the CPR's panels of distinguished neutrals. Judgment upon the award rendered by the Arbitrator shall be final and binding and may be entered by any court having jurisdiction thereof. The place of the arbitration shall be New York City, New York. The language of the arbitration shall be English. The neutral organization designated to perform the functions specified in Rule 6 and Rules 7.7(b), 7.8 and 7.9 shall be the CPR.

The company names, system names and product names mentioned in this manual are either registered trademarks or trademarks of their respective companies.

In some cases, trademark symbols such as '™' or '®' are not specified in this manual.

SICK SICK AG

www.sick.com

SH(NA)-080855ENG-M(2305)MEE

MODEL: WS-CPU-U-E

MODEL CODE: 13JZ32

MITSUBISHI ELECTRIC CORPORATION

HEAD OFFICE: TOKYO BLDG., 2-7-3, MARUNOUCHI, CHIYODA-KU, TOKYO 100-8310, JAPAN
NAGOYA WORKS: 1-14, YADA-MINAMI 5-CHOME, HIGASHI-KU, NAGOYA 461-8670, JAPAN

When exported from Japan, this manual does not require application to the
Ministry of Economy, Trade and Industry for service transaction permission.

Specifications subject to change without notice.