

Programmable Automation Controllers

MELSEC MX Controller

Quick Start Guide

MELSEC MX Controller MX-F Model

Motion function(Ladder Program)

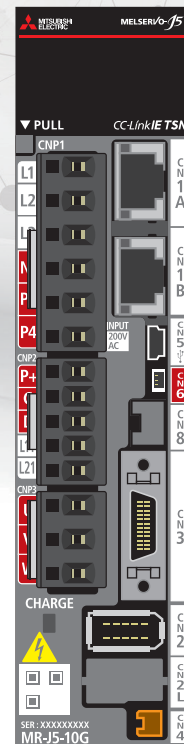
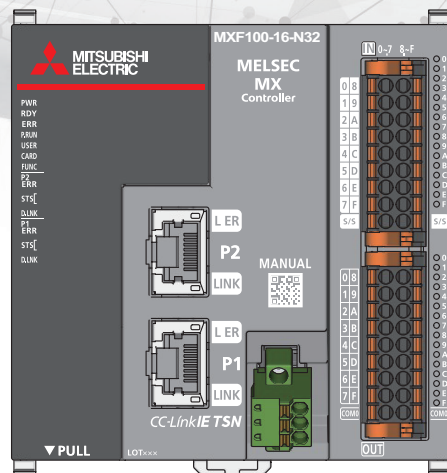



MELSEC MX Controller

SAFETY PRECAUTIONS

(Read these precautions before using this product.)

Before using Mitsubishi Electric programmable automation controllers, please read the manuals for the products used and the relevant manuals carefully and pay full attention to safety to handle the products correctly. If products are used in a different way from that specified by manufacturers, the protection function of the products may not work properly.

In this manual, the safety precautions are classified into two levels: "⚠️ WARNING" and "⚠️ CAUTION".

 WARNING	Indicates that incorrect handling may cause hazardous conditions, resulting in death or severe injury.
 CAUTION	Indicates that incorrect handling may cause hazardous conditions, resulting in minor or moderate injury or property damage.

Under some circumstances, failure to observe the precautions given under "⚠️ CAUTION" may lead to serious consequences.

Observe the precautions of both levels because they are important for personal and system safety.

When using the MELSEC iQ-F series extension devices, refer to the safety precautions described in the user's manual for the extension devices used.

[Design Precautions]

WARNING

- Configure safety circuits external to the controller to ensure that the entire system operates safely even when a fault occurs in the external power supply or the controller. Failure to do so may result in an accident due to an incorrect output or malfunction.
 - Emergency stop circuits, protection circuits, and protective interlock circuits for conflicting operations (such as forward/reverse rotations or upper/lower limit positioning) must be configured external to the controller system.
 - Note that when the controller detects an error, such as a watchdog timer error, during self-diagnosis, all outputs are turned off. Also, when an error that cannot be detected by the controller occurs in an input/output control block, output control may be disabled. External circuits and mechanisms should be designed to ensure safe machinery operation in such a case.
 - Outputs may remain on or off due to a failure of a component such as a relay and transistor in an output circuit. For output signals that may lead to serious accidents, external circuits and mechanisms should be designed to ensure safe machinery operation in such a case.
 - Construct an interlock circuit in the program so that the whole system always operates on the safe side before executing the control (for data change) of the controller system in operation. Read the manual thoroughly and ensure complete safety before executing other controls (program change, parameter change, forced output, and operation status change) to the controller system in operation. Improper operation may damage machines or cause accidents.
 - Configure an external safety circuit such as a fuse in the output circuit. When a load current exceeding the rated value or an overcurrent caused by a load short-circuit flows for a long time, it may cause smoke and fire.
 - For the operating status of each station after a communication failure, refer to manuals relevant to the network. Incorrect output or malfunction may result in an accident.
 - To ensure that the entire system operates safely, configure interlock circuits external to the controller. Failure to do so may result in an accident due to an incorrect output or malfunction.
 - OPR (Homing) is controlled by two kinds of data: an OPR direction and an OPR speed. Deceleration is performed when the proximity dog signal turns on. If an incorrect OPR direction is set, motion control may continue without deceleration.
 - When the controller detects an error, the operation decelerates and stops or suddenly stops, depending on the parameter settings. Set the parameters to meet the specifications of the system used.
 - If safety standards (such as robot safety rules) apply to the system using the controller, drive unit, and servo motor, ensure that the safety standards are satisfied.
 - Configure a safety circuit external to the module or drive unit if the abnormal operation of the controller or drive unit differs from the safety directive operation in the system.
-

[Design Precautions]

CAUTION

- When controlling an inductive load such as a lamp load, heater, or solenoid valve, take proper measures so that the flowing current does not exceed the value corresponding to the maximum load specification of the resistance load. A large current (approximately 10 times greater than normal) may flow when the output is turned on.
 - Design circuits so that the entire system will always operate safely even if the time required for the controller to enter the RUN state varies when the controller is powered off and on or reset. The time taken to enter the RUN state varies depending on the system configuration, parameter settings, and/or program size.
 - Simultaneously turn on and off the power supplies of the controller, extension modules, and expansion adapters.
 - If a long-time power failure or an abnormal voltage drop occurs, the controller stops, and output is turned off. When the power supply is restored, it will automatically restart (when the RUN/STOP/RESET switch is on RUN side).
-

[Security Precautions]

WARNING

- To maintain the security (confidentiality, integrity, and availability) of the controller and the system against unauthorized access, denial-of-service (DoS) attacks, computer viruses, and other cyberattacks from unreliable networks and devices via network, take appropriate measures such as firewalls, virtual private networks (VPNs), and antivirus solutions.
-

[Installation Precautions]

WARNING

- Make sure to cut off all phases of the power supply externally before attempting installation or wiring work. Failure to do so may cause electric shock or damage to the product. Use the product within the generic environment specifications described in the product manual.
 - Never use the product in areas with excessive dust, oily smoke, conductive dust, corrosive gas (salt air, Cl₂, H₂S, SO₂, or NO₂), flammable gas, or vibration or impacts, or expose it to high temperature, condensation, or rain and wind. If the product is used in such conditions, electric shock, fire, malfunctions, deterioration or damage may occur.
-

[Installation Precautions]

CAUTION

- Do not touch the conductive parts of the product directly. Doing so may cause device failures or malfunctions.
 - When drilling screw holes or wiring, make sure that cutting and wiring debris do not enter the ventilation slits of the controller system. Failure to do so may cause fire, equipment failures or malfunctions.
 - Install the product on a flat surface. If the mounting surface is rough, undue force will be applied to the PC board, thereby causing nonconformities.
 - Install the product securely using a DIN rail.
 - Connect the expansion adapter securely to their designated connectors. Loose connections may cause malfunctions.
 - Work carefully when using a screwdriver such as installation of the product. Failure to do so may cause damage to the product or accidents.
 - Connect the extension cables, peripheral cables, input/output cables and battery connecting cable securely to their designated connectors. Loose connections may cause malfunctions.
 - When using an SD memory card, insert it into the SD memory card slot. Check that it is inserted completely. Poor contact may cause malfunction.
 - Turn off the power before attaching or detaching the following devices. Failure to do so may cause equipment failures or malfunctions.
 - Peripheral devices, expansion adapter, and connector conversion adapter
 - Extension modules and connector conversion module
 - Battery
 - Hold the connector part of the Ethernet cable and perform installation or removal in a straight direction. If the cable is pulled out while connected to the module, it may cause damage to the module or the cable, or may cause a malfunction due to poor cable contact.
-

[Wiring Precautions]

WARNING

- Make sure to cut off all phases of the power supply externally before attempting installation or wiring work. Failure to do so may cause electric shock or damage to the product.
 - Connect the power supply wiring to the dedicated terminals described in the product manual. If an AC power supply is connected to a DC input/output terminal or DC power supply terminal, the controller will burn out.
 - The temperature rating of the cable should be 80°C or more. It may differ depending on the extension devices. For details, refer to the user's manual of the extension devices.
 - Make sure to perform wiring in accordance with the following precautions. Failure to do so may cause electric shock, equipment failures, a short-circuit, wire breakage, malfunctions, or damage to the product.
 - The disposal size of the cable end should follow the dimensions described in the product manual.
 - Twist the ends of stranded wires and ensure that there are no loose wires.
 - Do not solder-plate the electric wire ends.
 - Do not connect more than the specified number of wires or electric wires of unspecified size.
 - Affix the electric wires so that neither the terminal block nor the connected parts are directly stressed.
 - For details on wiring for the MELSEC iQ-F series modules such as intelligent function modules and expansion adapters, refer to the manuals for each product.
-

[Wiring Precautions]

CAUTION

- For the controller system, provide a ground resistance of 100Ω or less according to the product manual.
 - Install controller so that excessive force will not be applied to terminal blocks, I/O connectors, communication connectors, or communication cables. Failure to do so may result in wire damage/breakage or controller failure.
 - Make sure to observe the following precautions to prevent any damage to the machinery or accidents due to malfunction of the controller caused by abnormal data written to the controller due to the effects of noise.
 - Do not bundle the power line, control line and communication cables together with or lay them close to the main circuit, high-voltage line, load line or power line. As a guideline, lay the power line, control line and communication cables at least 100mm away from the main circuit, high-voltage line, load line or power line.
 - Ground the shield of the shield wire or shielded cable at one point on the controller system. However, do not use common grounding with heavy electrical systems.
 - Ground the shield of the analog I/O wire in accordance with the manuals of each model. However, do not use common grounding with heavy electrical systems.
-

[Computer Connection Precautions]

WARNING

- Do not ground on the +24V side. The controller is a non-insulated type, and the ground terminal of the power supply terminal and the FG metal fitting on the bottom of the product are conductive to the RJ45 connector shell (P1, P2) and the USB connector shell inside the controller. Therefore, the external power supply may be short-circuited depending on how peripheral devices are connected. Also, the connector shell and SG (24G) may have been short-circuited in the USB cable.
-

[Computer Connection Precautions]

CAUTION

- When connecting a personal computer to a controller having a USB interface, observe the following precautions as well as the instructions described in the manual for the personal computer used. Failure to do so may cause the controller to fail.
 - (1) When the personal computer is AC-powered
 - When the personal computer has a 3-pin AC plug or an AC plug with a ground wire, use a grounding receptacle or ground the ground wire. Ground the personal computer and the controller with a ground resistance of 100 ohms or less.
 - When the personal computer has a 2-pin AC plug without a ground wire, connect the computer to the module by following the procedure below. For power supplied to the personal computer and the controller, using the same power source is recommended.
 1. Unplug the personal computer from the AC receptacle.
 2. Check that the personal computer is unplugged from the AC receptacle. Then, connect the personal computer to the controller with a USB cable.
 3. Plug the personal computer into the AC receptacle.
 - (2) When the personal computer is battery-powered
 - The personal computer can be connected to the module without taking specific measures.For details, refer to the following.

Cautions When Using Mitsubishi Electric Controllers or GOTs Connected to a Personal Computer Via RS-232/USB Interface (FA-A-0298)
-

[Startup and Maintenance Precautions]

WARNING

- Do not touch any terminal while the power is on. Doing so may cause electric shock or malfunctions.
 - Before cleaning or retightening terminals, cut off all phases of the power supply externally. Failure to do so may cause electric shock.
 - Before modifying the program, performing forced output, or running or stopping the controller while the system is running, read through this manual carefully, and ensure complete safety. Improper operation may damage machines or cause accidents.
 - Do not change the program in the controller from two or more peripherals at the same time (such as from an engineering tool and a GOT). Doing so may cause destruction or malfunction of the controller program.
 - Use the battery for holding clock data in conformance to the product manual.
 - Use the battery for the specified purpose only.
 - Connect the battery correctly.
 - Do not charge, disassemble, heat, put in fire, short-circuit, connect reversely, solder, swallow, or burn the battery, or apply excessive forces (such as vibration, impact, drop) to the battery.
 - Do not store or use the battery at high temperatures or expose to direct sunlight.
 - Do not expose to water, bring near fire or touch liquid leakage or other contents directly.
 - When replacing the battery, make sure to use our specified product (FX3U-32BL).
 - When a battery error occurs (SM52 is on), follow the description in the product manual. Incorrect handling of the battery may cause heat excessive generation, bursting, ignition, liquid leakage or deformation, and lead to injury, fire or failures and malfunction of facilities and other equipment.
-

[Startup and Maintenance Precautions]

CAUTION

- Do not disassemble or modify the controller. Doing so may cause fire, equipment failures, or malfunctions. For repair, contact your local Mitsubishi Electric representative.
 - After the first use of the product, do not insert/remove the SD memory card to/from the controller more than 500 times. Exceeding the limit may cause malfunction.
 - Turn off the power before connecting or disconnecting any extension cable. Failure to do so may cause device failures or malfunctions.
 - Turn off the power before attaching or detaching the following devices. Failure to do so may cause device failures or malfunctions.
 - Peripheral devices, expansion adapter, and connector conversion adapter
 - Extension modules and connector conversion module
 - Battery
 - Do not use the chemicals for cleaning.
 - If there is the possibility of touching the controller system inside a control panel in maintenance, make sure to discharge to avoid the influence of static electricity.
 - Since there are risks such as burn injuries, please do not touch the surface of the equipment with bare hands when it is operating in an environment which exceeds ambient temperature of 40°C.
 - Use any radio communication device such as a cellular phone or PHS (Personal Handy-phone System) 25cm or more away in all directions from the controller system. Failure to do so may cause malfunction.
 - After power-off, wait for 1 second or more, then turn on the power. If the interval between power-off and on is insufficient, the module may not start up.
 - Before starting the operation, check if the brake function operates correctly.
 - Before testing the operation, set a low speed value for the speed limit parameter so that the operation can be stopped immediately upon occurrence of a hazardous condition.
 - Confirm and adjust the program and each parameter before operation. Unpredictable movements may occur depending on the machine.
 - When using the absolute position system, on starting up, and when the module or absolute position motor has been replaced, always perform a homing.
 - After maintenance and inspections are completed, check that the positions detected in the absolute position detection are correct.
-

[Operating Precautions]

CAUTION

- Construct an interlock circuit in the program so that the whole system always operates on the safe side before executing the control (for data change) of the controller in operation. Read the manual thoroughly and ensure complete safety before executing other controls (program change, parameter change, forced output, and operation status change) to the controller in operation. Improper operation may damage machines or cause accidents.
 - Do not go near the machine during test operations or during operations such as teaching. Doing so may lead to injuries.
 - When the reference axis speed specification is used in interpolation operation, the speed of the partner axis (2nd, 3rd, or 4th axis) may exceed the set speed and ultimately the speed limit value.
-

[Disposal Precautions]

CAUTION

- When disposing of this product, treat it as industrial waste.
 - When disposing of batteries, separate them from other wastes according to the local regulations. For details on battery regulations in EU member states, refer to the following.
 MELSEC MX Controller MX-F Model User's Manual
-

[Transportation Precautions]

CAUTION

- When transporting the controller with the optional battery, turn on the controller before shipment, confirm that SM52 is off, and check the battery life. If the controller is transported with the on status of SM52 or the battery exhausted, the battery-backed data may be unstable during transportation.
 - The controller system is a precision instrument. During transportation, avoid impacts larger than those specified in the general specifications by using dedicated packaging boxes and shock-absorbing pallets. Failure to do so may cause failures in the controller system. After transportation, verify operation of the controller system and check for damage of the mounting part or other parts.
 - When transporting lithium batteries, follow required transportation regulations. (For details on the regulated products, refer to the product manual.)
 - The halogens (such as fluorine, chlorine, bromine, and iodine), which are contained in a fumigant used for disinfection and pest control of wood packaging materials, may cause failure of the controller system. Prevent the entry of fumigant residues into the controller system or consider other methods (such as heat treatment) instead of fumigation. The disinfection and pest control measures must be applied to unprocessed raw wood.
-

INTRODUCTION

Thank you for purchasing the Mitsubishi Electric programmable automation controllers.

This guide describes the procedures before operation, parameters, and troubleshooting of the relevant products listed below. Before using this product, please read this guide and the relevant manuals carefully and develop familiarity with the functions and performance of the controller to handle the product correctly.

When applying the program examples provided in this guide to an actual system, ensure the applicability and confirm that it will not cause system control problems.

Note that the menu names and operating procedures may differ depending on an operating system in use and its version.

When reading this guide, replace the names and procedures with the applicable ones as necessary.

Please make sure that the end users read this guide.



The MELSEC MX Controller MX-F Model can be used in combination with the MELSEC iQ-F series modules.

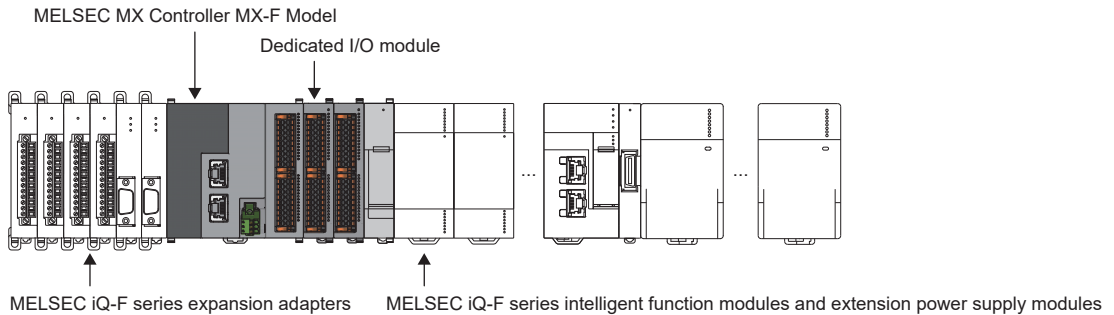

For details on the MELSEC iQ-F series modules or hardware specifications of the expansion adapters, refer to the following.

MELSEC iQ-F FX5S/FX5UJ/FX5U/FX5UC User's Manual (Hardware)

Relevant products

- MXF100-8-N32, MXF100-8-P32, MXF100-16-N32, MXF100-16-P32

CONTENTS

SAFETY PRECAUTIONS	1
INTRODUCTION	10
RELEVANT MANUALS	13
CHAPTER 1 MELSEC MX CONTROLLER	14
CHAPTER 2 SYSTEM START-UP	16
2.1 Equipment Overview	16
2.2 System Configuration	17
2.3 Equipment Preparation	18
2.4 Software Installation	19
Installation of GX Works3	19
2.5 Controller Wiring	20
2.6 Rotary Switch Settings	21
2.7 Powering on and Checking LED Status	22
CHAPTER 3 PARAMETER SETTINGS	24
3.1 Parameter Setting Procedure	24
3.2 Creating a Project	25
Initializing the controller	27
3.3 Connection Between the Personal Computer and Controller	28
3.4 Network Settings	30
Setting a network configuration	30
3.5 Motion Setting	32
PDO mapping	32
Servo parameter settings	33
Axis parameter settings	36
Driver unit conversion (electronic gear)	44
Reflecting axis parameters	49
Axes group settings	50
3.6 Saving a Project	53
3.7 Writing to the Controller	54
CHAPTER 4 PROGRAM EXAMPLES	55
4.1 Creation Procedure for Controller Programs	56
Creating a program block	56
Program execution types	57
How to input an FB	58
4.2 Label	62
Naming rules for labels	62
Global label list	63
4.3 Project Structure	66
Program name	66
4.4 PLC READY (Program Name: ServoON_Jog)	67
4.5 Servo ON (Program Name: ServoON_Jog)	68
4.6 JOG Operation (Program Name: ServoON_Jog)	69
4.7 OPR (Program Name: Homing)	74
4.8 Single Axis Positioning Control (Program Name: Positioning)	78

4.9	Single Axis Continuous Positioning (Program Name: ContinuousPosition)	80
4.10	Interpolation Control (Program Name: LinearInterpolation)	87
	Procedure for interpolation control	87
	Enabling/disabling an axes group	87
	Interpolation control	87
	Program example for linear interpolation	88
4.11	Synchronous Control (Program Name: Synchronous)	98
	Procedures for executing synchronous control	98
	Operation profile	99
	Single axis synchronous control FBs	101
	Axes configuration	101
	Program example for synchronous control	102
4.12	Error Reset (Program Name: ErrorReset)	113
4.13	Checking Operation	117
	Converting and writing programs	117
	Axis monitor	118
	Program monitor	119
	Watch	119
	Event history	120

APPENDICES **121**

Appendix 1	Changing the Number of Axes in a Project	121
	Procedure for changing the number of axes	121
Appendix 2	Using External Input Signals	123
	Using the DI signals of the servo amplifier	123
	Using the input signals of the controller	131
	Using the input signals of the remote input module	135
Appendix 3	Precautions to Use Absolute Position Detection System	141
REVISIONS	142

RELEVANT MANUALS

MELSEC MX Controller

Manual name [manual number]	Description
Quick Start Guide MELSEC MX Controller MX-F Model Motion Function(Ladder Program) [L08983-A] (this guide)	System start-up, parameter settings, and programming methods
MELSEC MX Controller MX-F Model User's Manual [SH-082634ENG]	Procedures before operation, specifications, devices, memory, functions, parameters, and troubleshooting of the controller
MELSEC MX Controller MX-F Model Programming Manual [SH-082691ENG]	Program language specifications, controller instructions, standard functions/function blocks, and specifications of motion control function blocks

Software

Manual name [manual number]	Description
GX Works3 Operating Manual [SH-081215ENG]	System configuration, parameter settings, and online operations of GX Works3
CPU Module Logging Configuration Tool Version 1 Operating Manual [SH-082478ENG]	System configuration and operation/setting procedures when using CPU Module Logging Configuration Tool

Servo amplifier

Manual name [manual number]	Description
MR-J5-G/MR-J5W-G User's Manual (Introduction) [SH-030294ENG]	Start-up of the servo amplifier
MR-J5 User's Manual (Hardware) [SH-030298ENG]	Installation, wiring, and usage of options
MR-J5 User's Manual (Function) [SH-030300ENG]	The functions necessary for operating the servo amplifier
MR-J5-G/MR-J5W-G User's Manual (Communication Function) [SH-030302ENG]	The functions necessary for using the communication function
MR-J5-G/MR-J5W-G User's Manual (Object Dictionary) [SH-030304ENG]	The object dictionary used in the servo amplifier
MR-J5-G/MR-J5W-G User's Manual (Parameters) [SH-030308ENG]	The parameters used in the servo amplifier
MR-J5 User's Manual (Troubleshooting) [SH-030312ENG]	Troubleshooting used to identify the cause of alarm and warning occurrences

1 MELSEC MX CONTROLLER

A MELSEC MX Controller MX-F Model (referred to as the controller in this guide) can achieve the following:

Integration of sequence control, motion control, and network control

Since multiple cores can process different tasks at the same time, high-speed parallel processing of sequence control, motion control, and network control can be achieved.

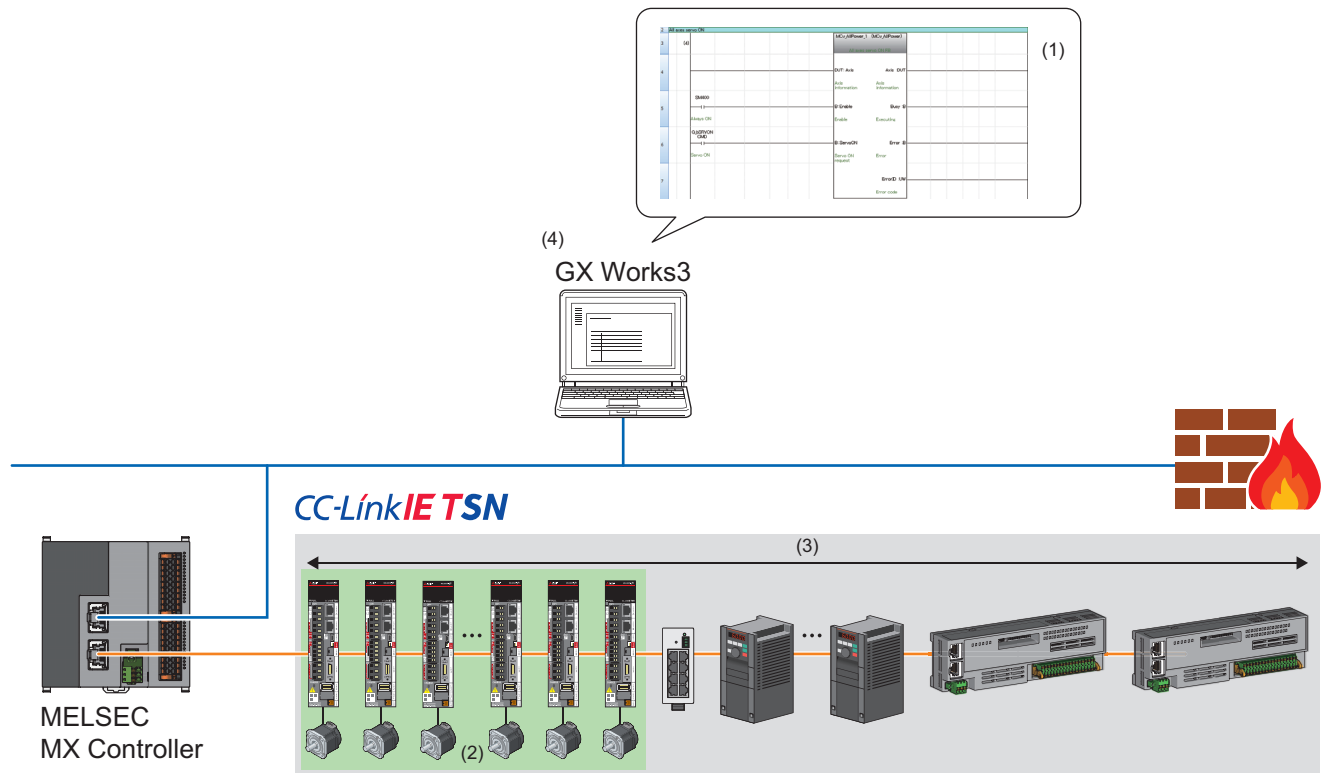

- (1) Sequence control
- (2) Motion control (Up to 16 axes used for motion control (with multi-axis servo amplifiers))
- (3) Network control (Up to 46 device stations connected)
- (4) Engineering tool

■Controlling the entire line by a single controller

- Servo amplifiers, inverters, and remote I/O modules can be connected on CC-Link IE TSN.
- CC-Link IE TSN and Ethernet can be connected simultaneously using the two LAN ports.

■Improving efficiency by a single engineering tool

- Sequence control and motion control can be set and programmed with a single engineering tool.
- The primary judgment at an occurrence of trouble can be quickly determined using each monitor or diagnostic window.

■Protecting information assets by security measures

- User authentication and communication encryption can prevent data leakage and unauthorized access.
- Data tampering is detected, and the execution of unauthorized programs is prevented.

Sequence and motion control in a single program

Sequence control and motion control can be written in a single program.

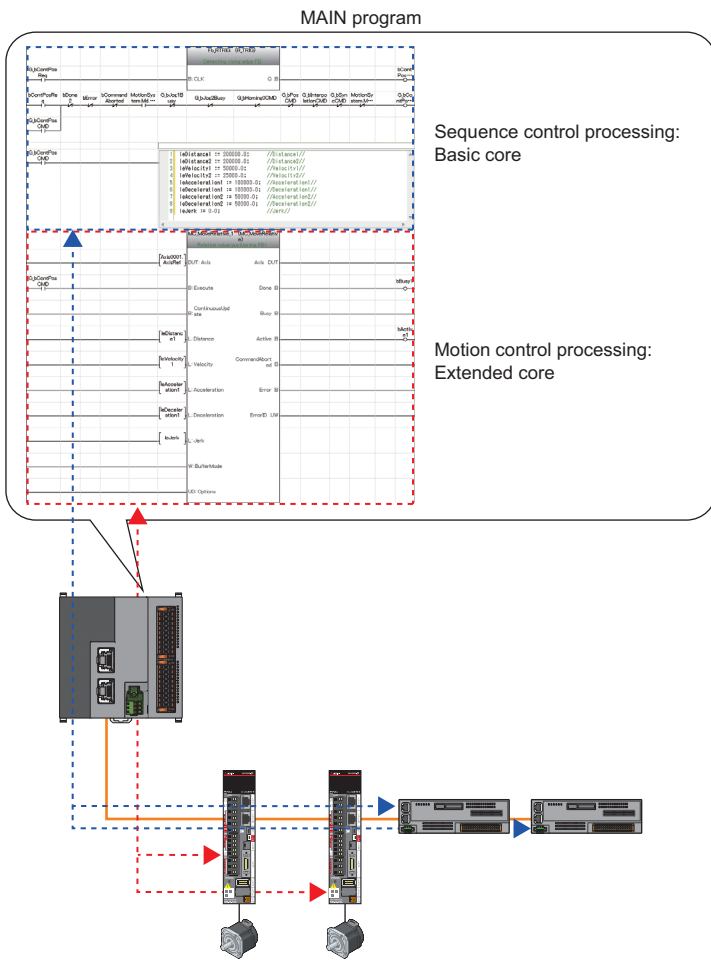

In the program, the sequence control part is processed in the basic core, and the motion control part is processed in the extended core. Each part is processed separately.

Programming in multiple languages

Both sequence and motion control can be created in the ladder diagram, structured text language (ST), and function block diagram language (FBD).

Ladder diagram

```

1 MC_MoveRelative_1(
2   Axis:= Axis001.AxisRef ,
3   Execute:= G_bContPosCMD ,
4   ContinuousUpdate:= FALSE ,
5   Distance:= leDistance1 ,
6   Velocity:= leVelocity1 ,
7   Acceleration:= leAcceleration1 ,
8   Deceleration:= leDeceleration1 ,
9   Jerk:= leJerk ,
10  BufferMode:= MC_BUFFER_MODE__mcAborting ,
11  Options:= H00000000 ,
12  Done=> bBusy1 ,
13  Active=> bActive1 ,
14  CommandAborted=> bCommandAborted ,
15  Error=> bError ,
16 );
17
                
```

Structured text language (ST)

Function block diagram language (FBD)

2 SYSTEM START-UP

2.1 Equipment Overview

This guide uses a two-axis system with ball screws as an example throughout the explanation.

Equipment

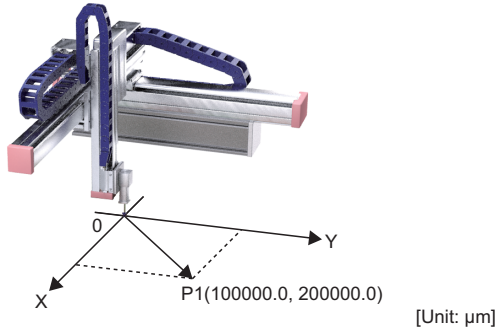

■ Specification

Item	Description
Lead of the ball screw (PB)	10.0 [mm]
Reduction ratio (NL/NM)	1/2 (load side [NL]/motor side [NM]) Each time the servo motor rotates twice, the ball screw of the load side rotates once.
Encoder resolution	26 bits (67108864 [pulses])

2.2 System Configuration

This section describes the system configuration example using a controller, servo amplifier (MR-J5-G), and servo motor (HK-KT series).

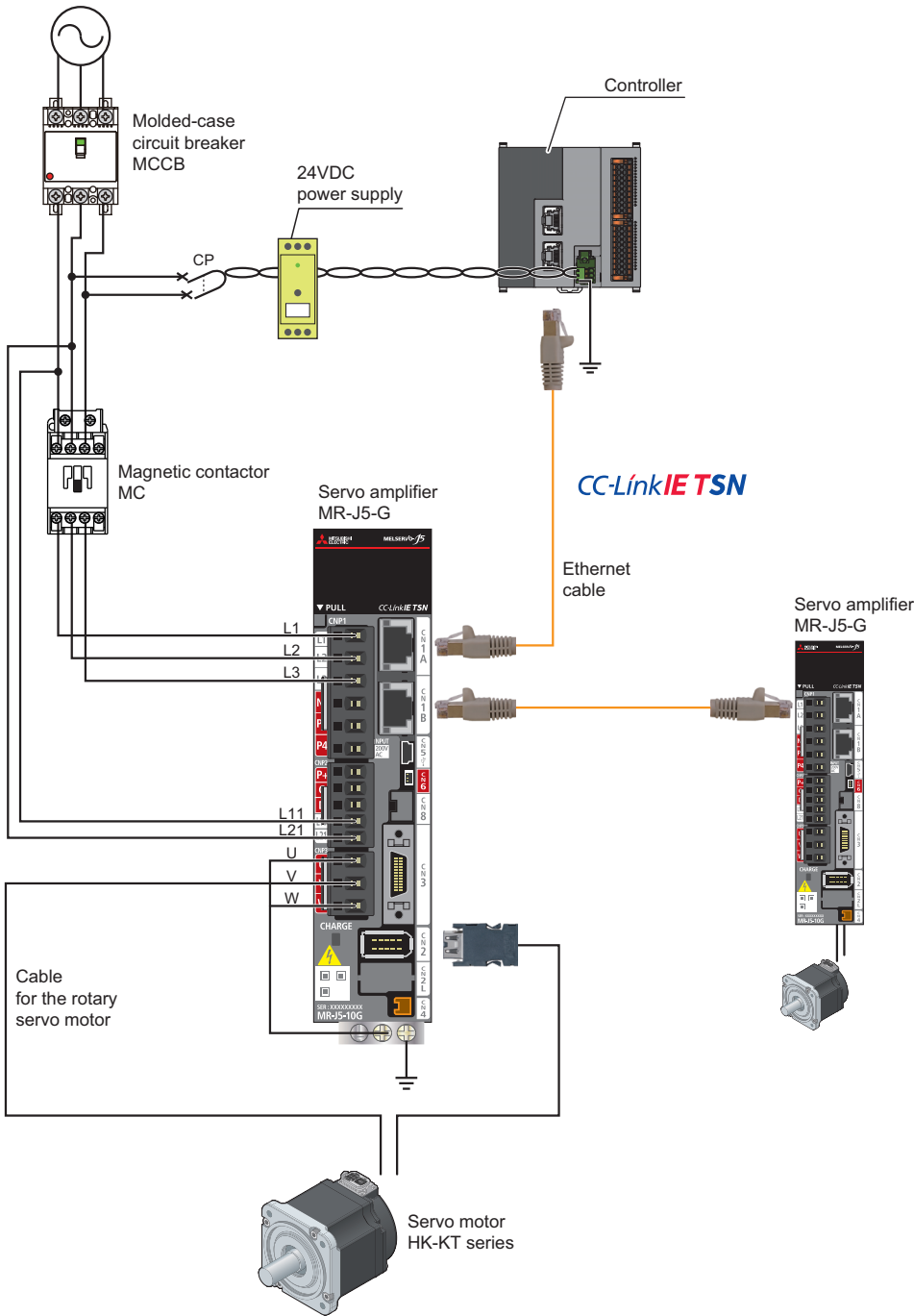

2.3 Equipment Preparation



This guide is based on the project using the following devices.

Prepare items (such as a controller, cables, and software) depending on the user's system.

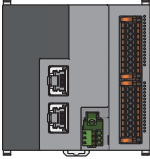
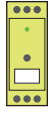
Control device

Controller	24VDC power supply
MXF100-16-N32 	

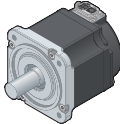
Servo amplifier/Servo motor

Servo amplifier	Servo motor	Cable for the rotary servo motor
MR-J5-10G 	HK-KT13W 	MR-AEP2CBL2M-A1-L 



Engineering tool

GX Works3



(Version"1.115V" or later)

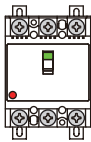
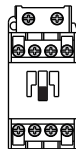

Power distribution control products

Molded-case circuit breaker (MCCB)	Magnetic contactor (MC)	Circuit protector (CP)
		

Communication/setting cable

Ethernet cable	USB cable
Category 5e or higher* ¹ 	Controller side: Type-C connector 

*1 This is a straight cable (shielded STP) that supports communication speeds up to 1Gbps.

2.4 Software Installation

Installation of GX Works3

Before installation

- Log on to the personal computer as an "Administrator".
- Close all running applications before installation. If the product is installed while other applications are running, it may not operate normally.

Procedure

Install GX Works3 using one of the following methods.

■Installing from the GX Works3 DVD

1. Insert the GX Works3 product DVD-ROM into the DVD-ROM drive and then double-click "setup.exe" in Disk1 folder.
2. Select or enter the required items according to the instruction on the window. *1

*1 Product ID is written on "License certificate" included with the product. Enter the 12-digit number divided into 3 and 9 digits.

■Downloading and installing the update module (update version)

1. After unzipping the downloaded zip file to a desired location, double-click "sw1dnd-gxw3-j_****.exe"^{*1} in the folder.
*1 **** indicates GX Works3 version
2. Select or enter the required items according to the instruction on the window.

2.5 Controller Wiring

This section describes the power supply wiring of a controller. Connect the DC power supply to the +24V and 24G terminals. For the wiring of the servo amplifier and connection examples of each cable, refer to the following.

📖 MR-J5 User's Manual (Hardware)

Suitable wiring

The following table describes the wire to be connected to the power terminal block. The temperature rating of the cable should be 80°C or more.

Number of wires connected per terminal	Wire size		
	Solid wire, stranded wire ^{*1}	Ferrule with insulation sleeve	Ferrule without insulation sleeve
One wire	22 AWG (0.3mm ²)	22 to 16 AWG (0.3 to 1.5mm ²)	22 to 16 AWG (0.3 to 1.5mm ²)

*1 Use of a solid wire or stranded wire is not recommended.

Connection of the cable

Fully insert a wire with a ferrule into a wire insertion opening.

After inserting the wire, pull it lightly to check that it is securely clamped.

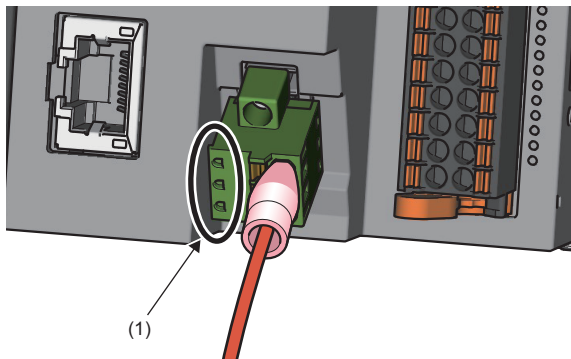

Point

Continuity can be checked with a test terminal (1).

Use the following test plug to check continuity.

- PHOENIX CONTACT GmbH & Co. KG test plug (φ1.0mm): MPS-MT 1-S4-B RD, MPS-MT 1-S

2.6 Rotary Switch Settings

The settings of the rotary switches (SW1 and SW2) of the servo amplifier correspond to the fourth octet of the IP address in the "CC-Link IE TSN Configuration" window.

<Rotary switches of the servo amplifier>

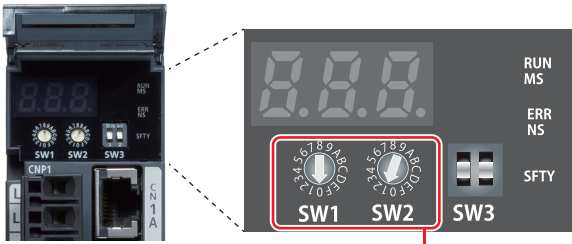

192.168.4.1 Set the fourth octet with the rotary switches (01 to FE).

<"Network basic" window for the servo amplifier>

No.	Name	Setting range	Station 1	Station 2
IP address setting				
NPA01	IP address setting	0-1	0 : Use rotary switch	0 : Use rotary switch
NPA02	IP address	-	192.168.3.1	192.168.3.1
NPA04	Subnet mask	-	255.255.255.0	255.255.255.0
NPA06	For manufacturer setting	00000000-FFFFFFFF	COA8 03FE	COA8 03FE
Host name				
NPA08	Host name	63 characters		
Extension				
NPA09	For manufacturer setting	00000000-0000FFFF	0000 0000	0000 0000
NPA10	For manufacturer setting	1-255	210	210
NPA11	For manufacturer setting	1-255	210	210
NPA12	Communication speed	00000001-00000002	2 : Network automatic setting	2 : Network automatic setting
Extension 2				
NPA13	For manufacturer setting	00000000-00000000	0000 0000	0000 0000
Extension 3				
NPA14	For manufacturer setting	00000000-FFFFFFFF	0000 0000	0000 0000
NPA15	For manufacturer setting	00000000-FFFFFFFF	0000 0000	0000 0000

Confirm that "0: Use rotary switch" is selected.

For IP address and network settings of a controller, refer to the following.

☞ Page 30 Network Settings

2.7 Powering on and Checking LED Status

Before powering on, connect a personal computer and a controller with a USB cable or an Ethernet cable.

Powering on the controller

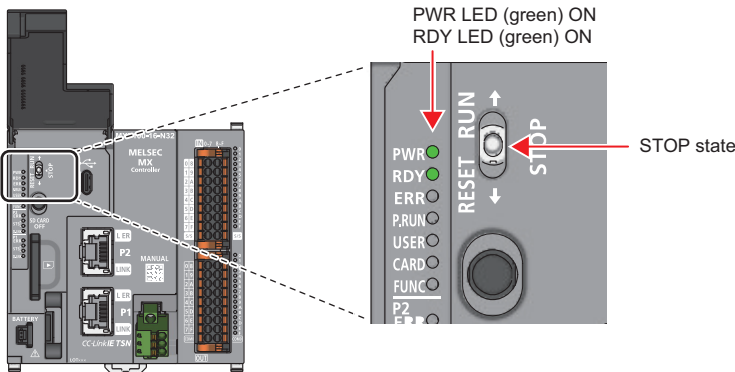

1. Check the wiring of a 24VDC power supply.
2. Check that the controller is in the STOP state.
3. Power on the controller.
4. Check that the LEDs of the controller are on.

LED indication	Description
PWR LED (green) ON RDY LED (green) ON	The ERR LED on the controller will blink red when the parameter and program are not yet written in the controller, but it is no problem. After writing parameter and program, when the controller is powered off and on, the ERR LED turns off.

Powering on the servo amplifier

Check the wiring of the servo amplifier, then turn on the control circuit power supply of the servo amplifier. The communication status with the controller can be checked on the display of the servo amplifier.

7-segment LED display of the servo amplifier (normal status)

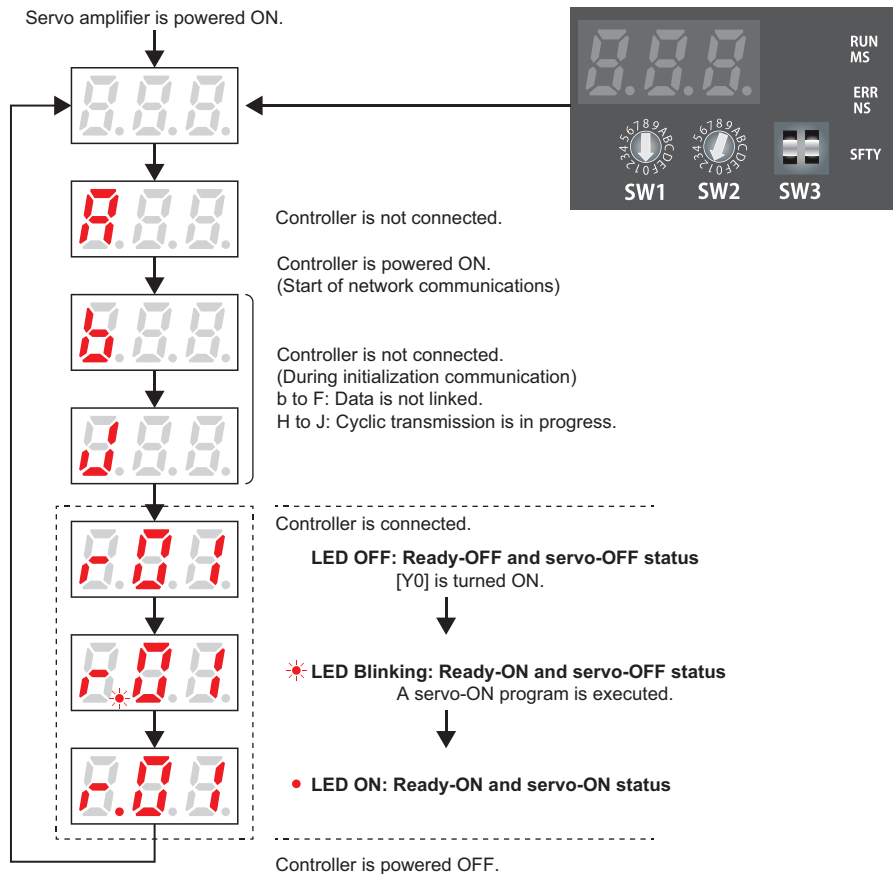

■When an alarm occurs on a 1-axis servo amplifier

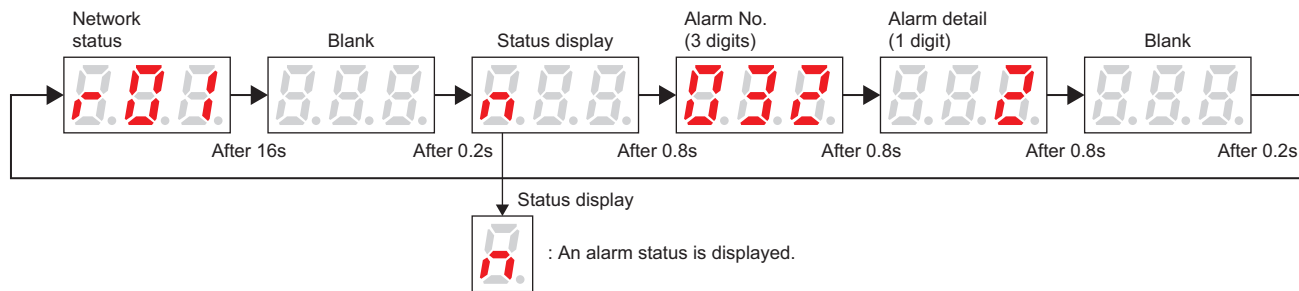

■7-segment LED display during a network connection

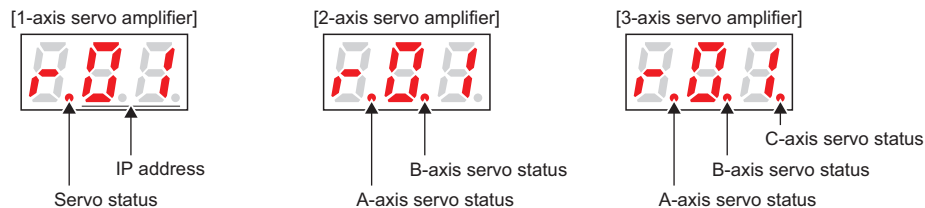

LED status

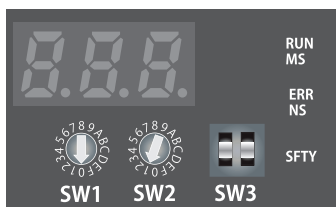

Status	Color	Description
RUN MS	Green	Off: An alarm has occurred. On: Power is on.
ERR NS	Red	Off: No alarms or warnings have occurred. Blinking: A warning has occurred. On: An alarm has occurred.
SFTY	Green	Off: Functional safety cannot be activated. On: Functional safety can be achieved.

3 PARAMETER SETTINGS

3.1 Parameter Setting Procedure

This section describes parameter setting procedures.

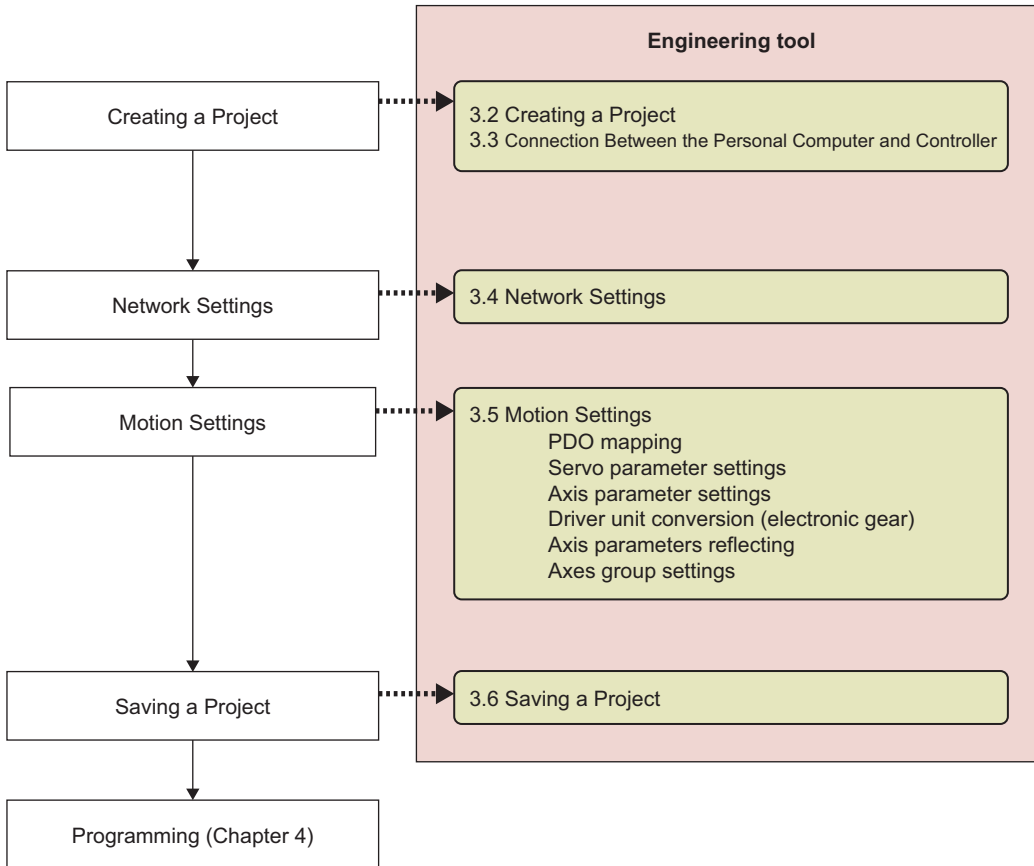

3.2 Creating a Project

Create a new project.

Operating procedure

1. Start the engineering tool.
2. Set the controller as follows.

 [Project] ⇨ [New]

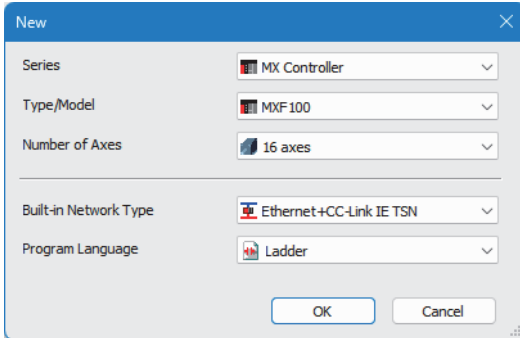

3. Click the [Yes] button.

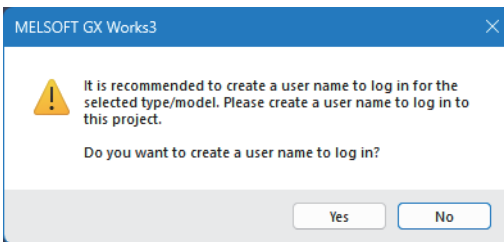

4. Configure each item and click the [OK] button.

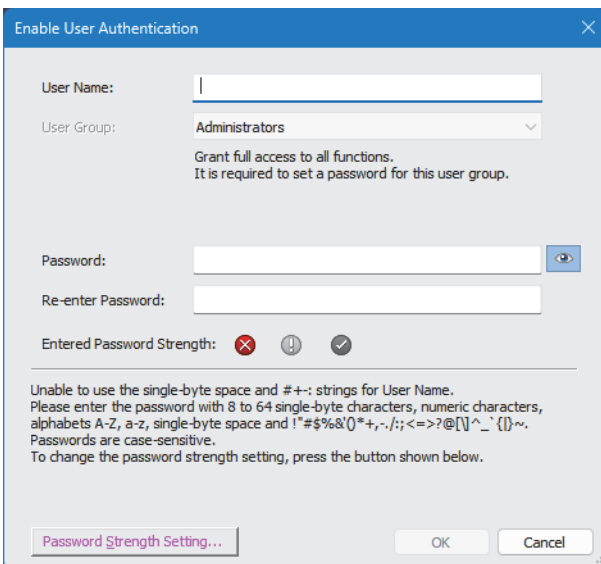

5. Configure each item and click the [Save] button.

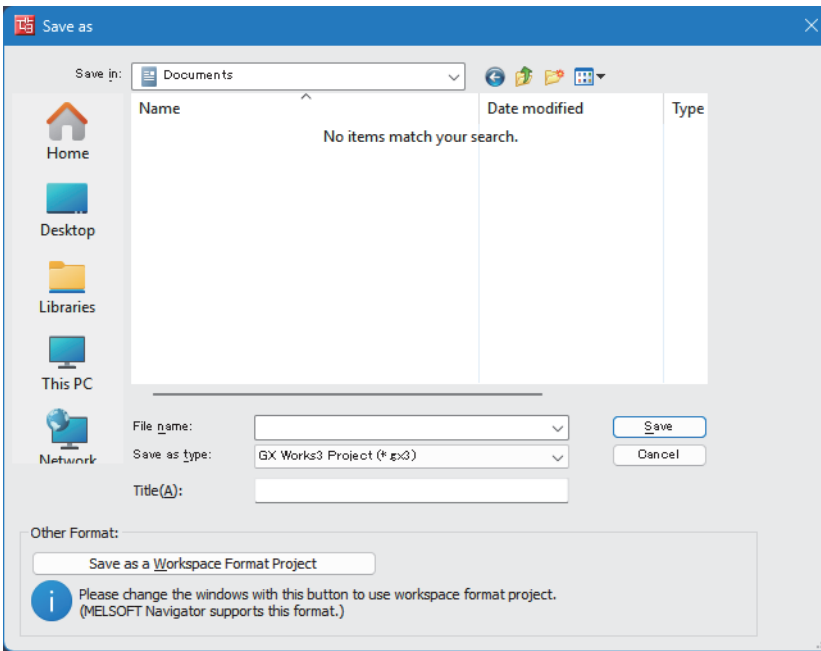

6. Click the [Setting Change] button and set the item that is to use module labels.

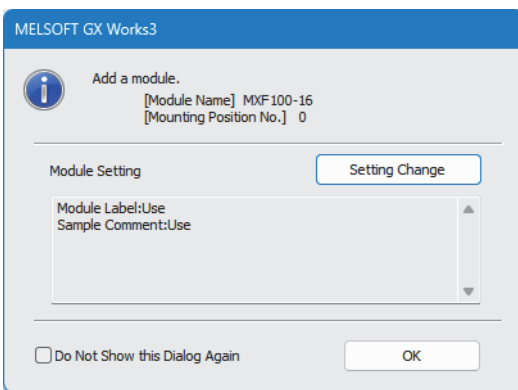

7. Click the [OK] button to create the project.

Initializing the controller

Since the memory data is undefined when the controller is shipped, initialize the memory.

Operating procedure

1. Click the [Initialization] button on the [CPU Memory Operation] window.

 [Online] ⇒ [CPU Memory Operation] on the menu bar

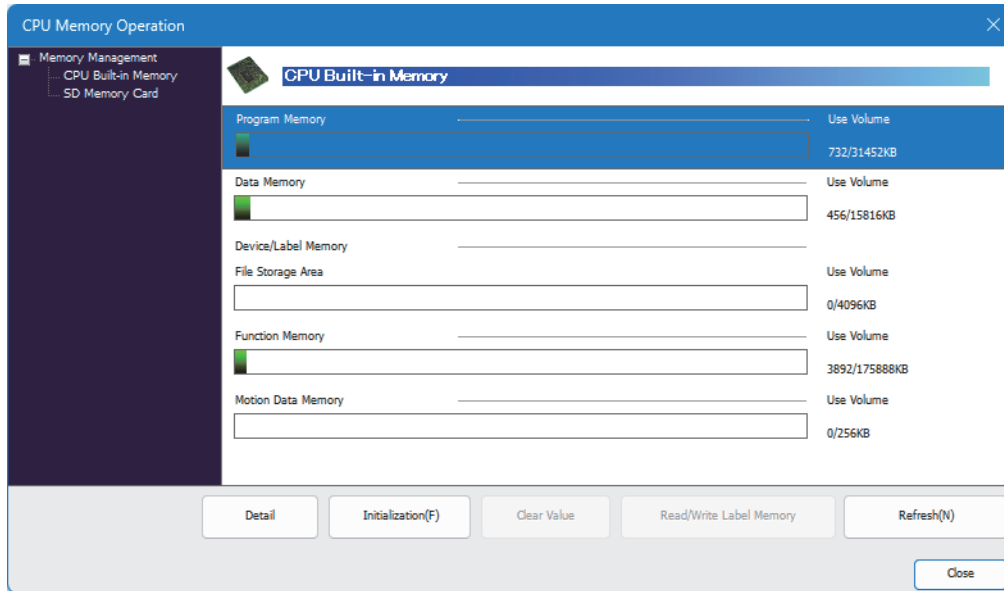

2. When the confirmation message appears, click the [Yes] button to start initialization.

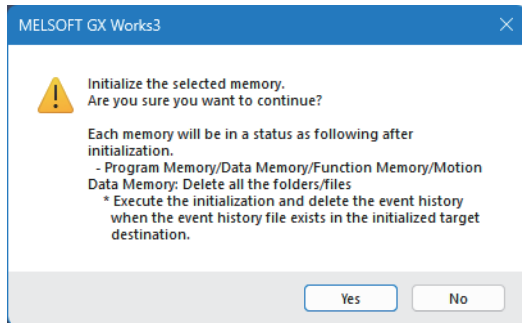

3. When initialization is complete, the completed message is displayed. Click the [OK] button.

3.3 Connection Between the Personal Computer and Controller

Check the connection between the personal computer and the controller.

Operating procedure

1. Connect the personal computer to the controller with a USB cable or an Ethernet cable.

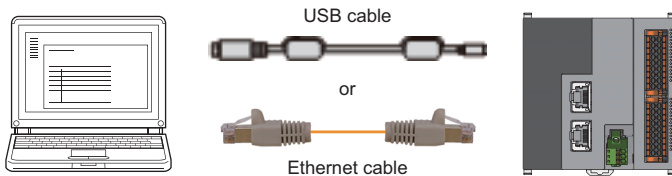

2. Click the [CPU Module Direct Coupled Setting] button on the "Specify Connection Destination" window.

 [Online] ⇌ [Current Connection Destination] on the menu bar

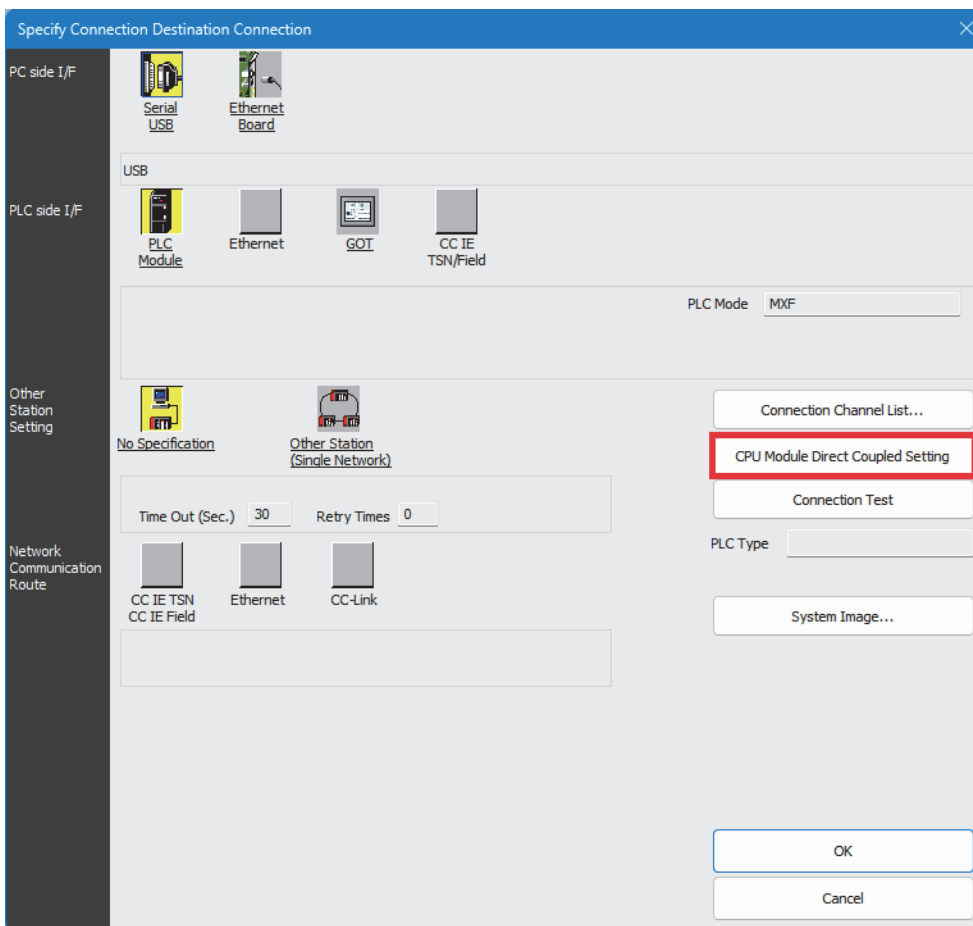

3. Select the connection method, and click the [Yes] button. (When selecting "Ethernet", specify the adapter.)

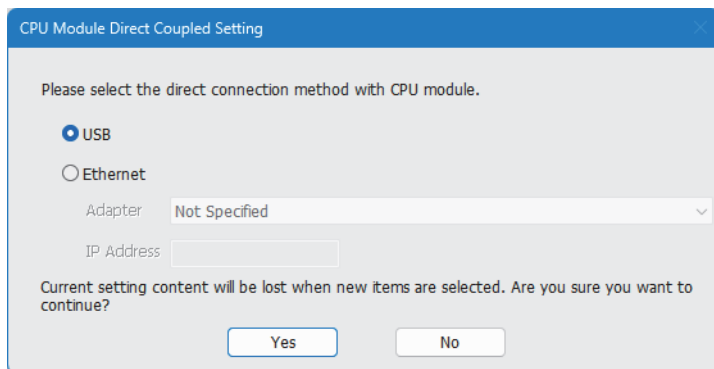

4. Click the [Connection Test] button on the "Specify Connection Destination" window to perform a connection test with the personal computer.

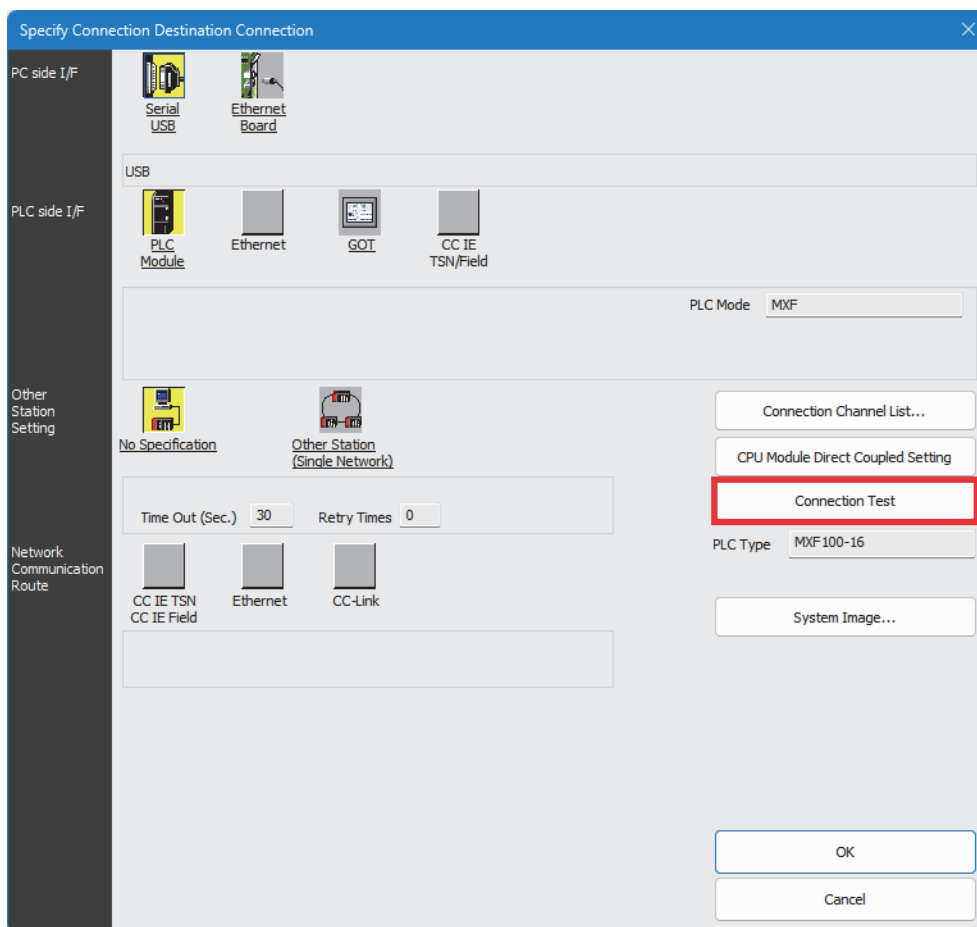

5. If the connection was successful, the successfully connected message appears. Click the [OK] button.

3.4 Network Settings

This section describes the settings for connecting the controller and servo amplifier.

Setting a network configuration

Operating procedure

1. Set "Network No." and "IP Address". The example in this guide uses the initial values.

Navigation window ⇒ [Parameter] ⇒ Controller ⇒ Module Parameter (CC-Link IE TSN port) ⇒ [Module Parameter (CC-Link IE TSN)] ⇒ [Required Settings]

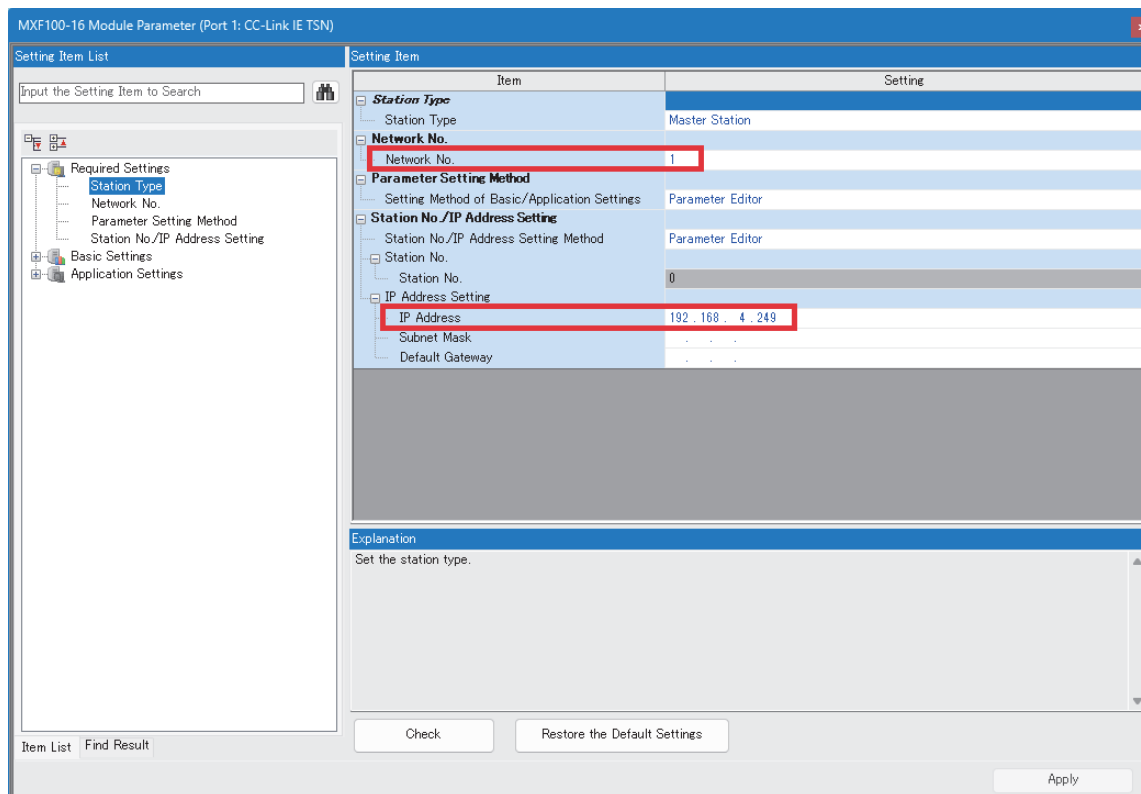

2. Double-click "<Detailed Setting>" in "Network Configuration Settings".

Navigation window ⇒ [Parameter] ⇒ Controller ⇒ Module Parameter (CC-Link IE TSN port) ⇒ [Module Parameter (CC-Link IE TSN)] ⇒ [Basic Settings]

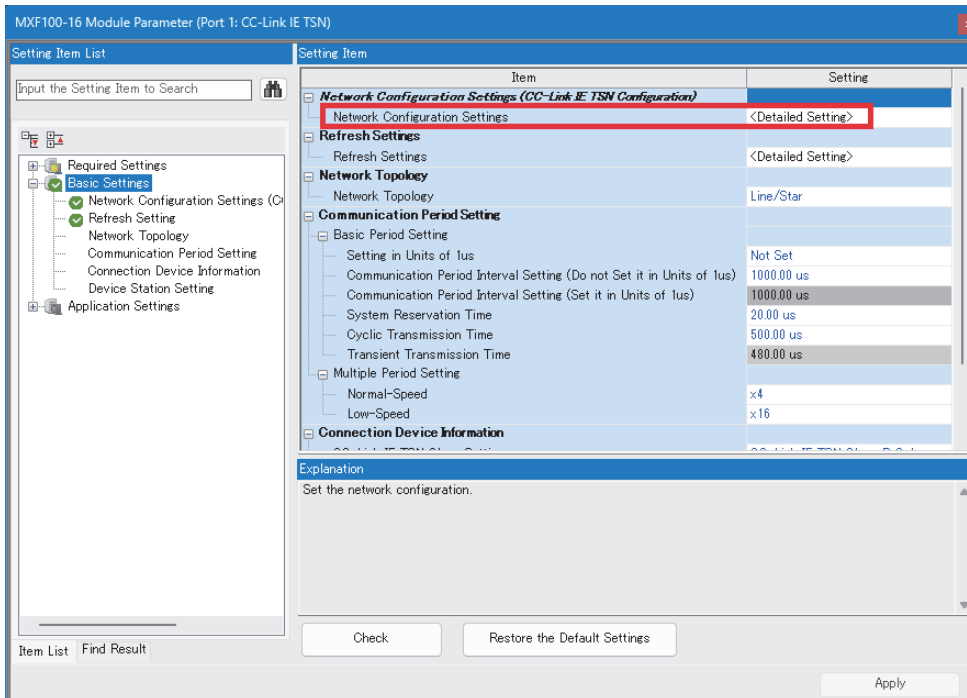

3. Select the devices to be used, and drag and drop them into their assigned position.

[CC-Link IE TSN Selection] tab in the module list ⇒ [General-Purpose AC Servo] in [CC-Link IE TSN Module (Mitsubishi Electric)]

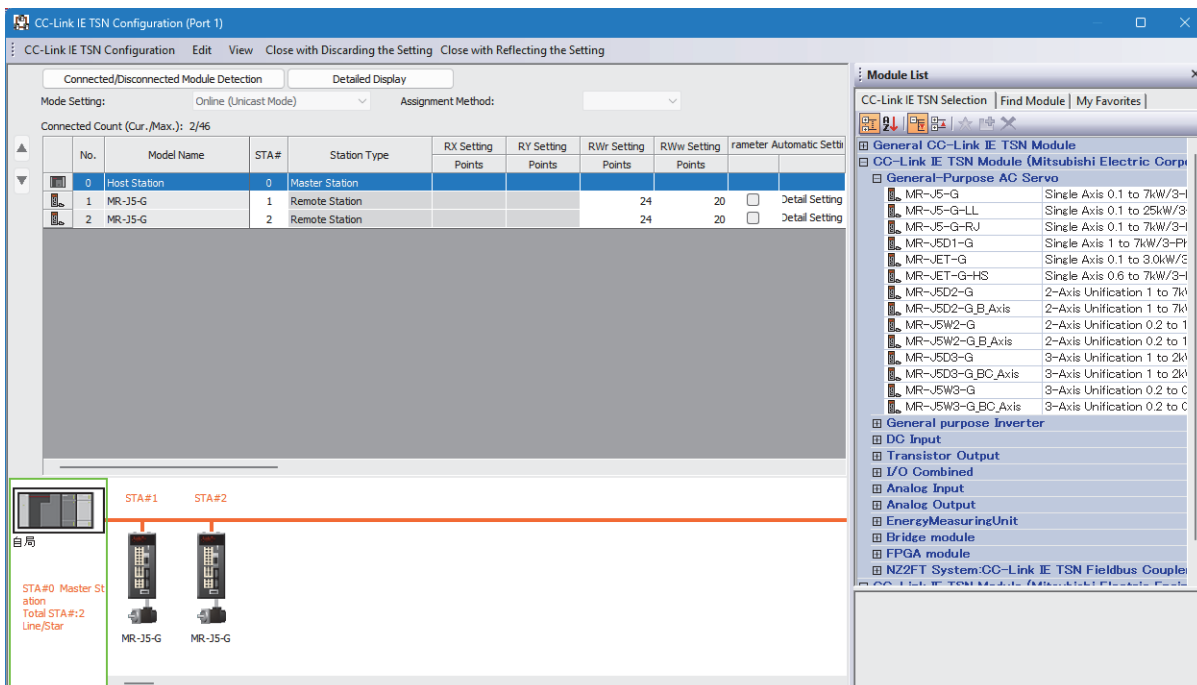

Point

The initial values are displayed in the station No. and the I/O points.

The IP address is assigned automatically based on the master station setting, the master station No., and the order the module is dropped.

3.5 Motion Setting

This section describes the parameter settings for the servo amplifier and the settings for using a real drive axis in the program.

PDO mapping

Set default data of the PDO mapping in a batch.

Operating procedure

1. From the menu on the "CC-Link IE TSN Configuration" window, select "Batch Setting of PDO Mapping" and then click the [Yes] button.

 Navigation window ⇒ [Parameter] ⇒ Controller ⇒ Parameter (CC-Link IE TSN port) ⇒ [Module Parameter (CC-Link IE TSN)] ⇒ [Basic Settings] ⇒ [Network Configuration Settings] ⇒ Double-click "Detailed Setting" ⇒ [CC-Link IE TSN Configuration] ⇒ [Batch Setting of PDO Mapping]

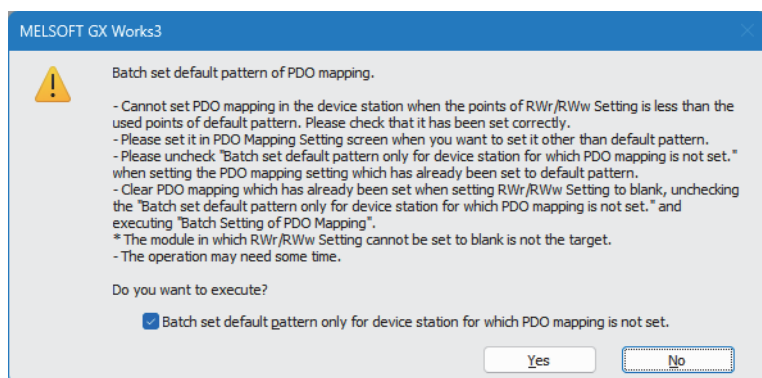

2. When the PDO mapping batch setting completes, the completed message appears. Click the [OK] button.

Point

PDO is an abbreviation for Process Data Object.

PDO communication is equivalent to the conventional CC-Link cyclic transmission.

PDO mapping performs mapping (associating) of data (objects) sent/received between the controller and the devices in cyclic transmission (PDO communication).

Servo parameter settings

There are two methods for writing parameters to servo amplifiers.

Writing method	Advantage	Disadvantage
Writing from the engineering tool to the controller	<ul style="list-style-type: none"> Batch-management of parameters Setting parameters without connecting servo amplifiers 	Taking time at the initial communication
Writing parameters from MR Configurator2 to servo amplifiers	Quick startup of servo amplifiers since transmission of parameters is not necessary at power-on	Necessary to write parameters to each servo amplifier

This guide describes the procedure for writing from the engineering tool to the controller.

Procedure for writing from the engineering tool to the controller

Operating procedure

1. Place a check in the "Parameter Automatic Setting" checkbox in the "CC-Link IE TSN Configuration" window to write parameters to the device stations from the master station at the initial communication.

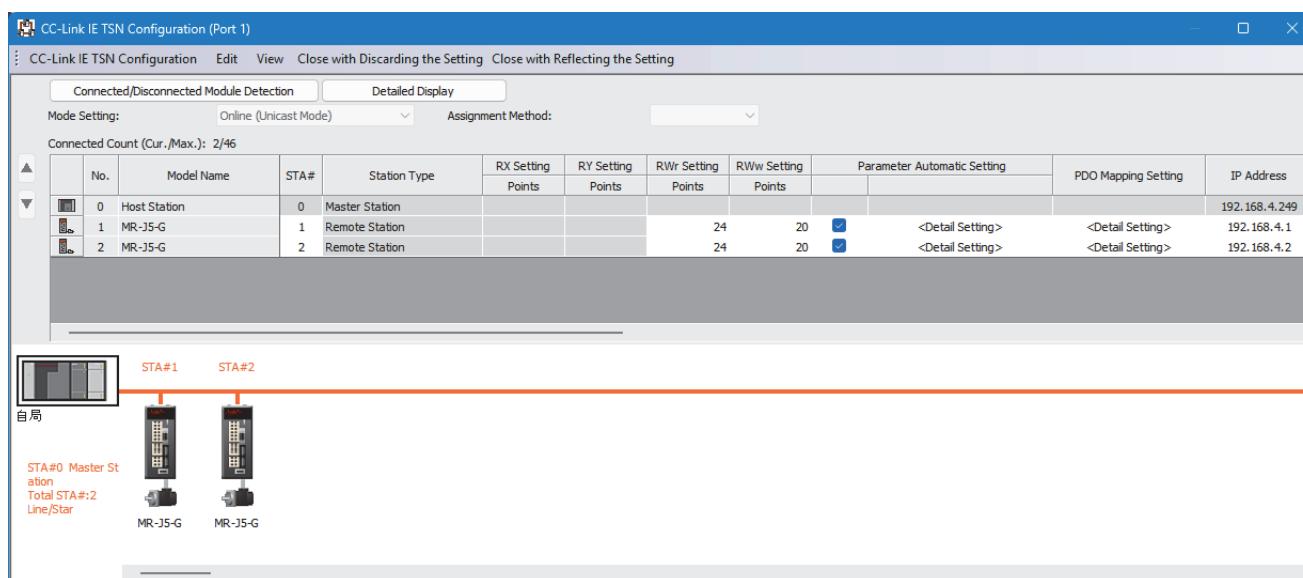

2. Double-click the illustration of the servo amplifier to be set.
3. When the confirmation message appears, click the [Yes] button.

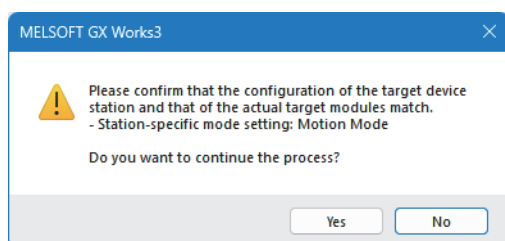

4. On the "Parameter Setting" window, set the servo parameters.

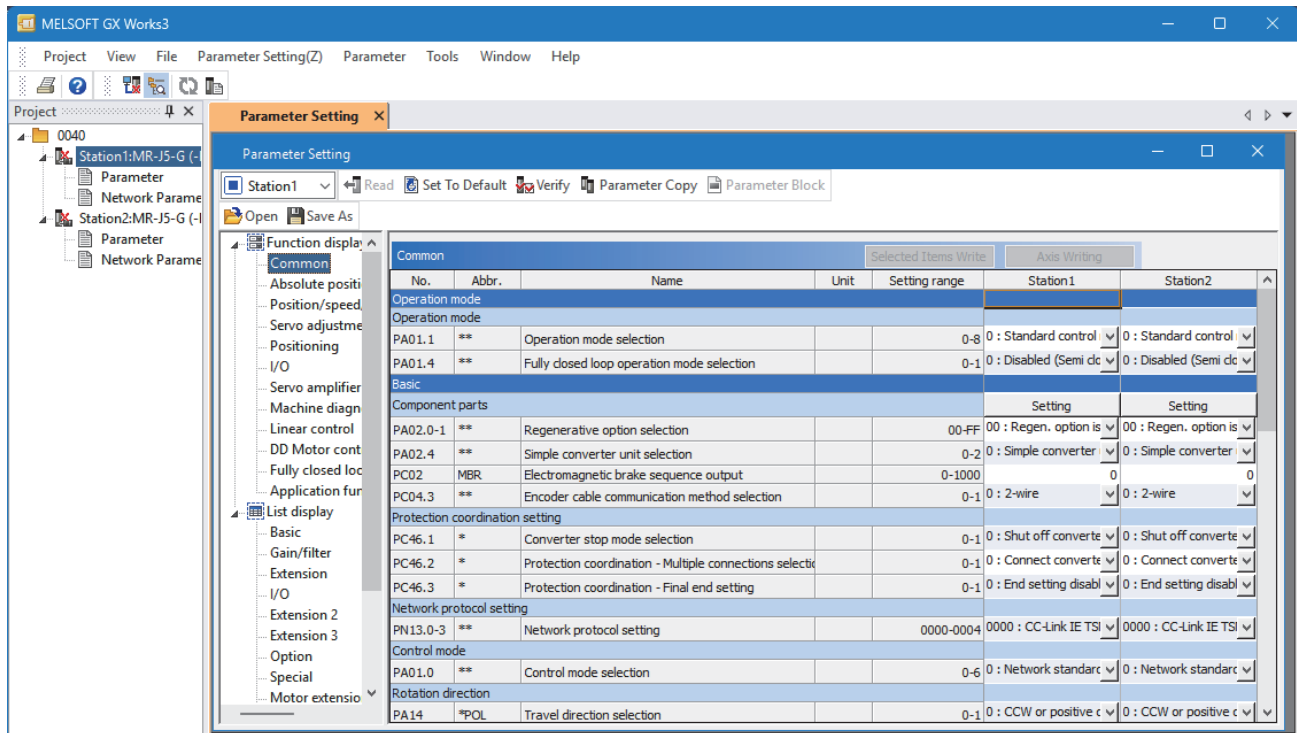

Change the following parameters.

Display	No.	Name	Setting value
[Common] ⇒ [Basic] ⇒ [Forced stop]	PA04.2	Servo forced stop selection	0: Enabled (Use forced stop input EM1 or EM2.) → 1: Disabled (The forced stop input EM1 and EM2 are not used.)
[I/O] ⇒ [Stroke limit function] ⇒ [Stroke limit function]	PC19.0	[AL.099 Stroke limit warning] selection	0: Enabled → 1: Disabled
	PD41.2	Limit switch enabled status selection	0: Limit switch always enabled → 1: Enabled only for homing mode

5. When the setting is complete, click the [X] button in the upper right corner of the "Parameter Setting" window.

6. When the confirmation message appears, click the [Yes] button to update the parameters.

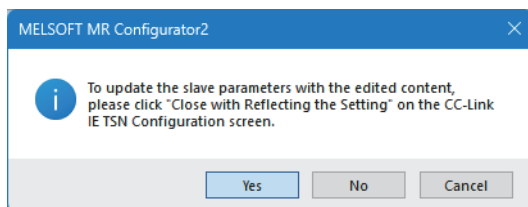

7. From the menu on the "CC-Link IE TSN Configuration" window, click the "Close with Reflecting the Setting" button.

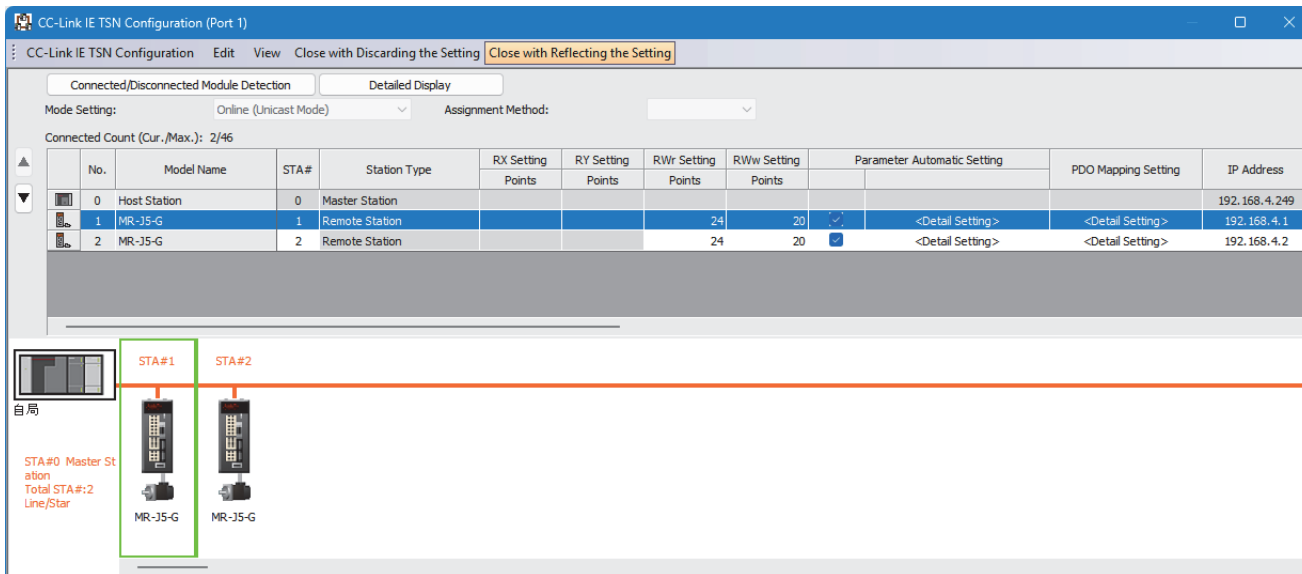

If the following warning message appears, click the [Yes] button.

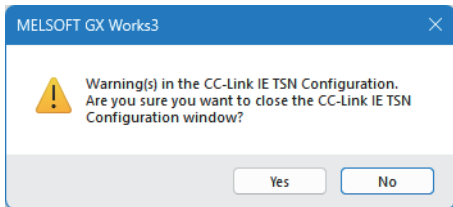

8. In the module parameters, click the [Apply] button to reflect the parameters of the controller.

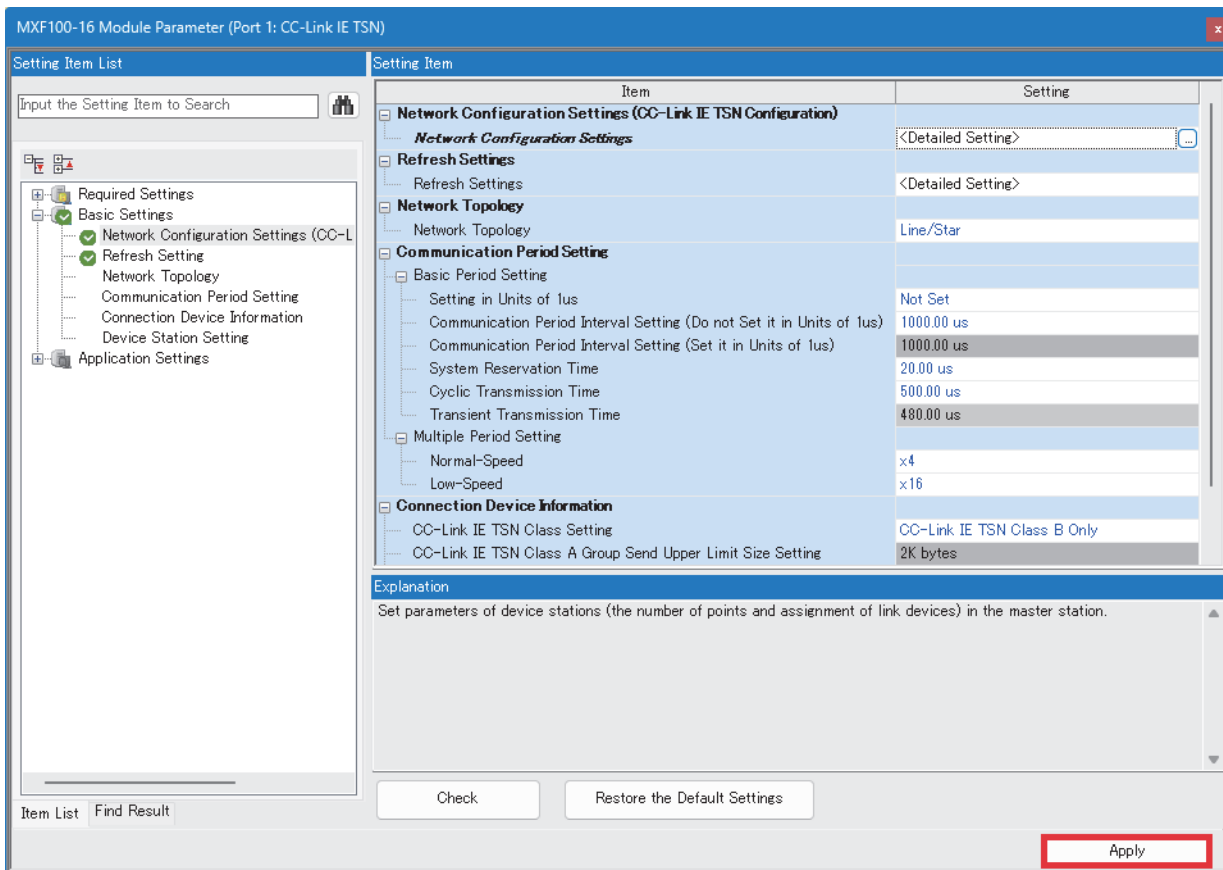

Axis parameter settings

Setting a station address and an axis type

There are five axis types.

Axis type	Description
Real drive axis	Outputs commands using a servo amplifier connected to CC-Link IE TSN.
Real encoder axis	Generates the current position from the output pulses of the synchronous encoder which is connected to a servo amplifier on CC-Link IE TSN.
Virtual drive axis	Virtually generates commands.
Virtual encoder axis	Virtually generates the current position from the variables.
Virtual linked axis	Virtually connects the single axis synchronous control FBs.

The example in this guide registers two real drive axes, one virtual drive axis, and two virtual linked axes.

Real drive axis

Set the station address to link the axis information in the axis parameter to the servo amplifier set in the network configuration.

Operating procedure

1. Right-click "Axis" in the Navigation window, and select "Add New Data".

 Navigation window ⇒ [Motion Setting] ⇒ [Axis]

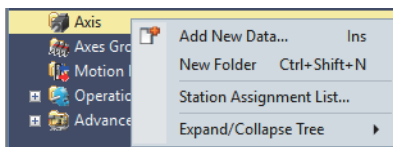

2. Click the [...] button on "Station Address Setting" to display the "Station Address Setting" window.

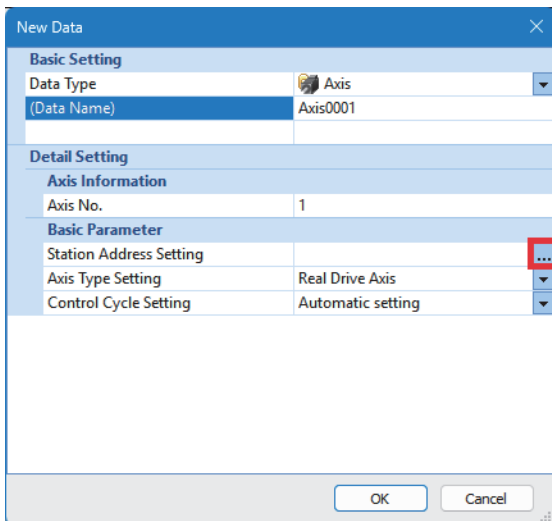

3. The station address can be set by selecting one of the IP addresses displayed on the "Station Address Setting" window and clicking the [OK] button.

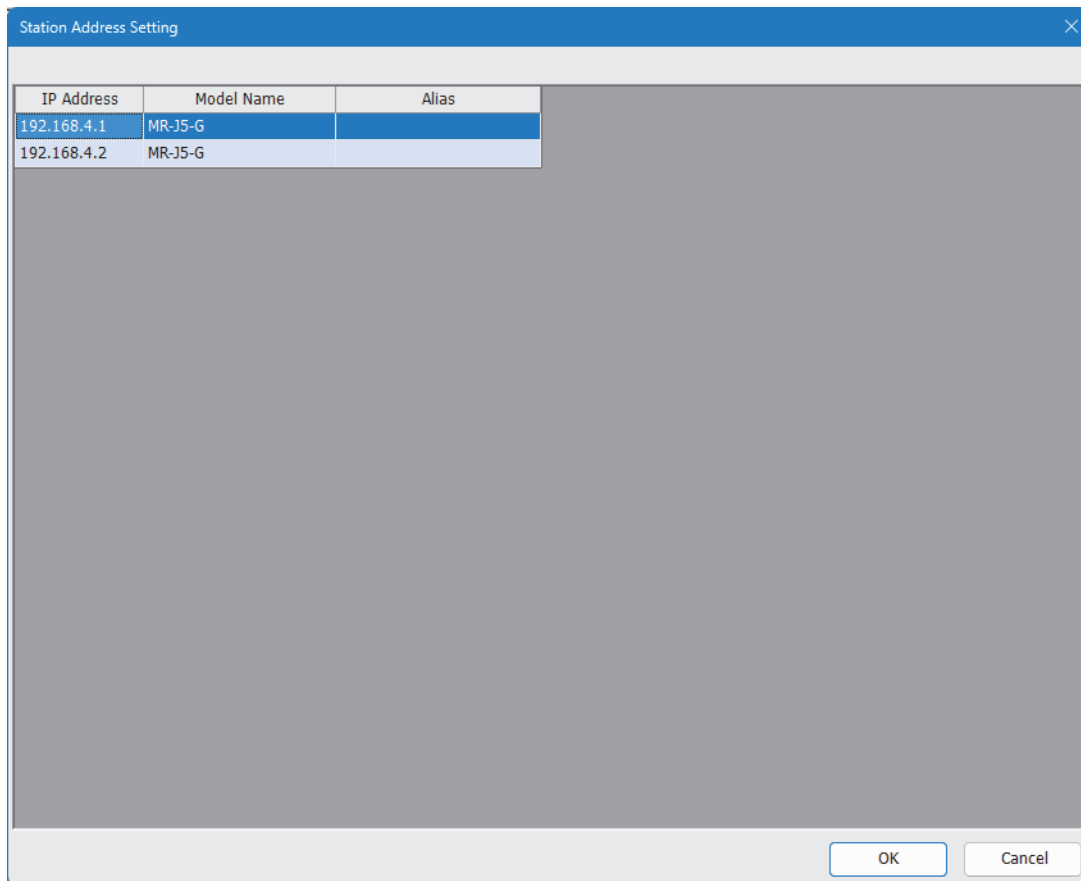

4. Enter "Data Name", "Axis No.", "Station Address Setting", and "Axis Type Setting", and click the [OK] button.

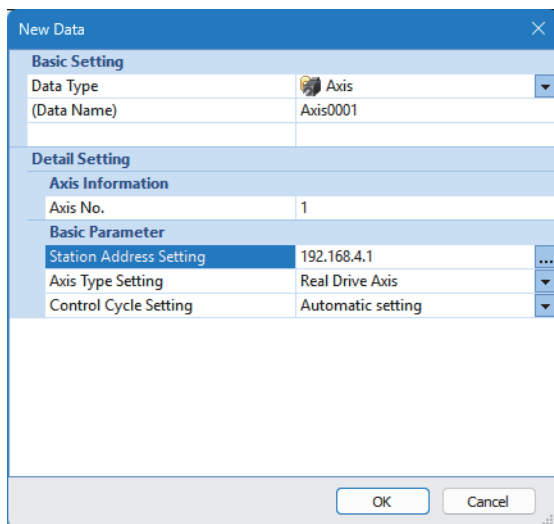

■Real drive axis setting description

The following is the setting example for the real drive axis in this guide.

Item	Setting value (1st axis)	Setting value (2nd axis)
Data Name	Axis0001	Axis0002
Axis No.	1	2
Station Address Setting	192.168.4.1	192.168.4.2
Axis Type Setting	Real Drive Axis	Real Drive Axis

Point

For the station address setting, use the IP address set in the "CC-Link IE TSN Configuration" window.
A multi-drop No. is shown when the station address for axes other than the first axis of a multi-axis servo amplifier is specified.

(Example) For B-axis of the MR-J5-W3 with "IP address: 192.168.4.1"

192.168.4.1#1
└─┬─┘ Multidrop number (#0: A axis, #1: B axis)
└───┘ IP address

Virtual drive axis

Set a virtual drive axis.

Operating procedure

1. Right-click "Axis" in the Navigation window, and select "Add New Data".

 Navigation window ⇨ [Motion Setting] ⇨ [Axis]

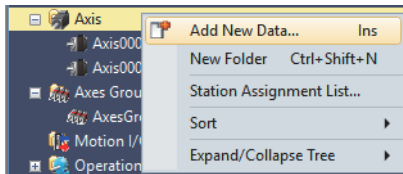

2. Enter "Data Name", "Axis No.", and "Axis Type Setting", and click the [OK] button.

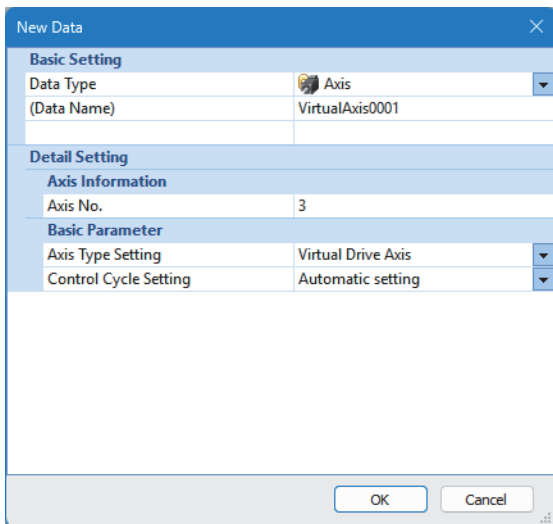

Virtual drive axis setting description

The following is the setting example for the virtual drive axis in this guide.

Item	Setting value
Data Name	VirtualAxis0001
Axis No.	3
Axis Type Setting	Virtual Drive Axis

Virtual linked axis

Set a virtual linked axis.

Operating procedure

1. Right-click "Axis" in the Navigation window, and select "Add New Data".

Navigation window ⇨ [Motion Setting] ⇨ [Axis]

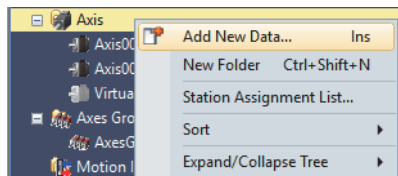

2. Enter "Data Name", "Axis No.", and "Axis Type Setting", and click the [OK] button.

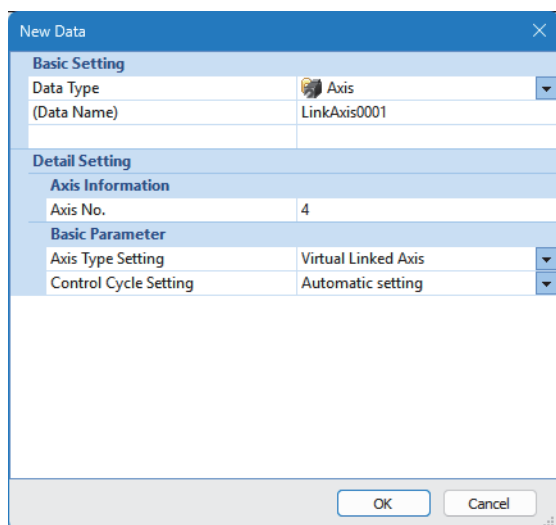

Virtual linked axis setting description

The following is the setting example for the virtual linked axis in this guide.

Item	Setting value (1st axis)	Setting value (2nd axis)
Data Name	LinkAxis0001	LinkAxis0002
Axis No.	4	5
Axis Type Setting	Virtual Linked Axis	Virtual Linked Axis

Setting each item

■ Real drive axis

1. In the "Axis Parameter Setting" window, set the axis parameters for Axis0001 and Axis0002.

 Navigation window ⇒ [Motion Setting] ⇒ [Axis] ⇒ double-click Axis0001 (Axis0002).

Item	Axis0001	Axis0002
Axis Information	Set Axis Information	
Axis No.	1	2
Basic Parameter	Set Basic Parameter	
Station Address Setting	192.168.4.1	192.168.4.2
Axis Type Setting	0:Real Drive Axis	0:Real Drive Axis
Axis Emulation Enabled	0:Disabled	0:Disabled
Control Cycle Setting	0:Automatic setting	0:Automatic setting
Object Data		
Absolute Position Contr	-1:Automatic Setting (Acquir	-1:Automatic Setting (Acquir
Current Position Restor	-1:Automatic judgement	-1:Automatic judgement
Ring Counter Enabled	0:Disabled	0:Disabled
Ring Counter Upper Lim	10000000000.0 um	10000000000.0 um
Ring Counter Lower Lim	-10000000000.0 um	-10000000000.0 um
Position Command Unit	um	um
Position Command Unit		
Velocity Command Unit	U/s	U/s
Velocity Bias Value	0.0 um/s	0.0 um/s
Driver Unit Conversion	67108864 pulse	67108864 pulse
Driver Unit Conversion	5000 um	5000 um
Limit Parameter	Set Limit Parameter	
Velocity Limit	Set Velocity Limit	
Homing	Set Homing	
Stop	Set Stop	
Stroke Limit	Set Stroke Limit	
Driver	Set Driver	
Other	Set Other	

The setting example for each real drive axis (Axis0001 and Axis0002) in this guide is shown below.

Item	Description	Setting value		
		Axis0001	Axis0002	
Basic Parameter	Station Address Setting	Set the IP address of the driver.		
	Position Command Unit	192.168.4.1	192.168.4.2	
	Velocity Command Unit	Set the position command unit and the velocity command unit used for the motion control.		
	Driver Unit Conversion Numerator	um*1	U/s	
	Driver Unit Conversion Denominator	67108864	5000	
Limit Parameter	Upper Limit Signal	Convert units of the target position and the actual position between the controller and the driver. For details on the setting method, refer to the following.  Page 44 Driver unit conversion (electronic gear)		
	Lower Limit Signal	Set the hardware stroke limit switches at the upper/lower limit of the movable range by assigning external signals.		
Homing	Start Permission at Homing Uncompleted	Set whether axis start is allowed or not for when the homing request is TRUE.		
Stop	Forced Stop Signal	Set the forced stop signal.		
	Stop Signal	Signal	Initial value	
		Target	[VAR]G_bStopSignalX*2	[VAR]G_bStopSignalY*2
		Signal Detection Method	Initial value	
		Compensation Time		
Filter Time				
Stroke Limit	Software Stroke Limit Target	Set the range and the target of the software stroke limit.		
	Software Stroke Limit Upper Value	Initial value		
	Software Stroke Limit Lower Value			

*1 um indicates micrometer (μm).

*2 A global label is registered for the stop signal. For setting the global labels, refer to the following.

 Page 63 Global label list

Virtual drive axis

1. In the "Axis Parameter Setting" window, set the axis parameters for VirtualAxis0001.

Navigation window ⇒ [Motion Setting] ⇒ [Axis] ⇒ Double-click VirtualAxis0001.

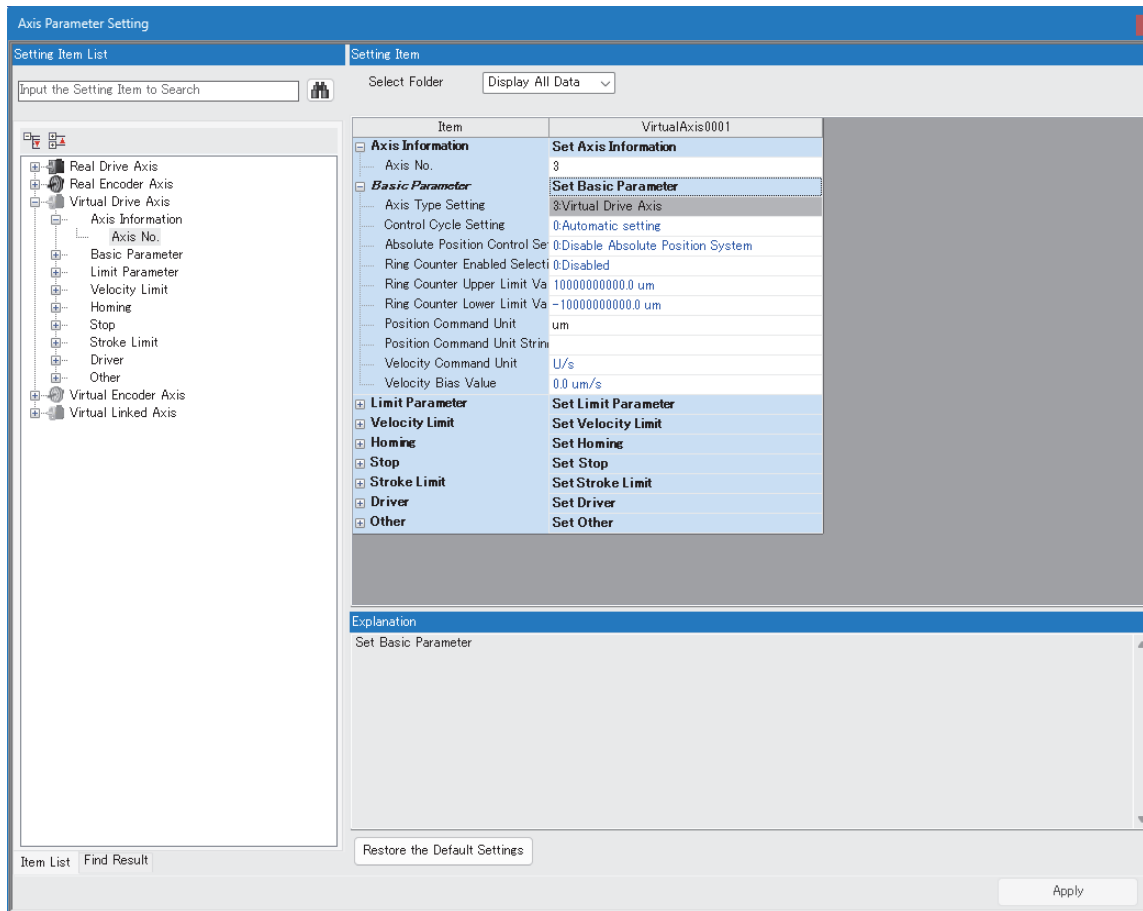

The following is the setting example for the virtual drive axis (VirtualAxis0001) in this guide.

Item		Description	Setting value
			VirtualAxis0001
Axis Parameter	Position Command Unit	Set the position command unit and the velocity command unit used for the motion control.	um ^{*1}
	Velocity Command Unit		U/s

*1 um indicates micrometer (μm).

Virtual linked axis

1. In the "Axis Parameter Setting" window, set the axis parameters for LinkAxis0001 and LinkAxis0002.

Navigation window ⇒ [Motion Setting] ⇒ [Axis] ⇒ double-click LinkAxis0001 (LinkAxis0002).

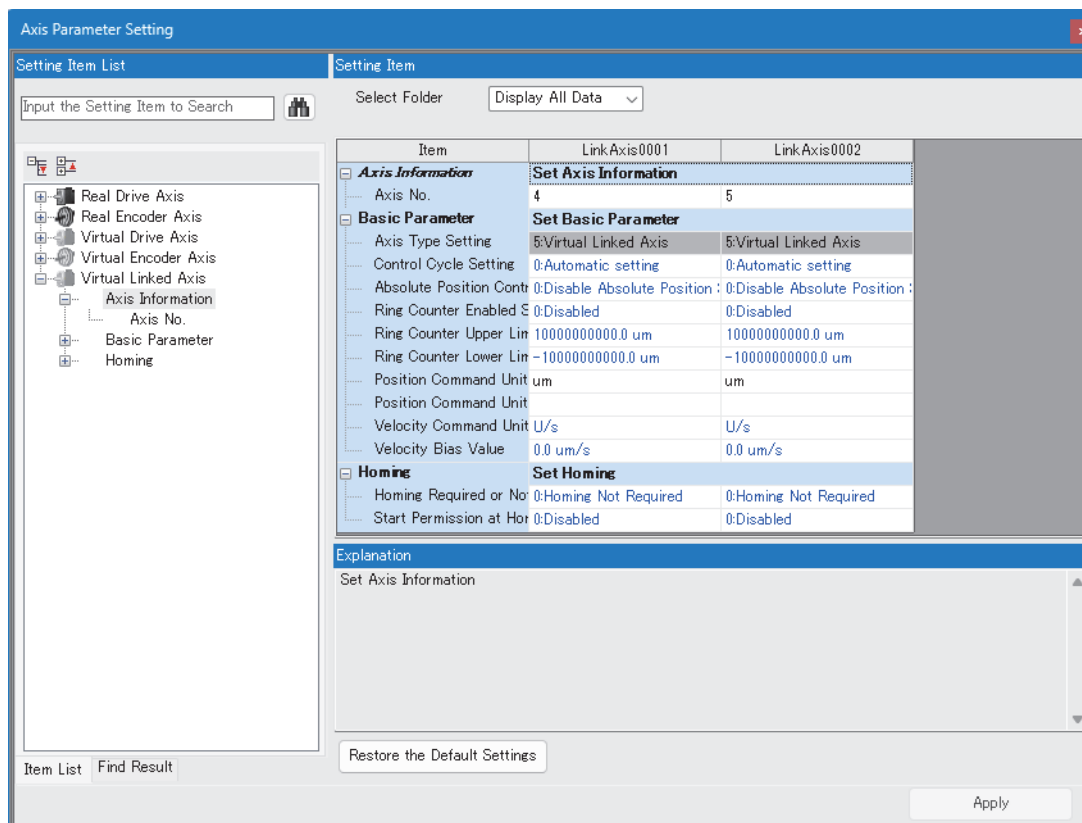

The setting example for each virtual linked axis (LinkAxis0001 and LinkAxis0002) in this guide is shown below.

Item		Description	Setting value	
			LinkAxis0001	LinkAxis0002
Axis Parameter	Position Command Unit	Set the position command unit and the velocity command unit used for the motion control.	um ^{*1}	um ^{*1}
	Velocity Command Unit		U/s	U/s

*1 um indicates micrometer (μm).

Driver unit conversion (electronic gear)

A setting example of the driver unit conversion numerator/driver unit conversion denominator is shown below.

About the electronic gear

■ Ball screw

67108864pulse

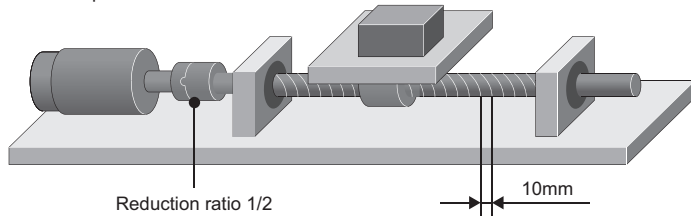

Item	Setting value
Servo motor encoder resolution	67108864pulse (26 bits)
Lead of the ball screw	10mm (10000 μ m)
Reduction ratio	1/2 (load side [NL]/motor side [NM]) Each time the servo motor rotates twice, the ball screw of the load side rotates once.

$$\frac{\text{Driver unit conversion numerator}}{\text{Driver unit conversion denominator}} = \frac{\text{Number of encoder pulses}}{\text{Movement amount} \times \text{Reduction ratio}} = \frac{67108864}{10000 \times 1/2} = \frac{67108864}{5000}$$

- Driver unit conversion numerator = Number of pulses per rotation 67108864
- Driver unit conversion denominator = Movement amount per rotation 5000

Electronic gear setting

The procedure for setting the electronic gear is shown below.

3

Operating procedure

1. In the "Axis Parameter Setting" window, click "Axis Parameter" ⇒ [...] button for "Driver Unit Conversion Numerator" to display the "Electronic Gear Setting" window.

Navigation window ⇒ [Motion Setting] ⇒ [Axis] ⇒ double-click Axis0001.

The screenshot shows the 'Axis Parameter Setting' window. On the left is a tree view of 'Setting Item List' with 'Driver Unit Conversion Numerator' selected. The main area displays a table of parameters for 'Axis0001' and 'Axis0002'. The 'Driver Unit Conversion Numerator' parameter is highlighted with a red box, showing a value of '1 pulse' for both axes. Below the table is an 'Explanation' section with the formula: $\text{Target Position Inside Motion System [controller unit]} \times \text{Driver Unit Conversion Numerator} / \text{Driver Unit Conversion Denominator} = \text{Target Position Inside Driver [driver unit]}$. The 'Apply' button is visible at the bottom right.

Item	Axis0001	Axis0002
Position Command Unit String		
Velocity Command Unit	U/s	U/s
Velocity Bias Value	0.0 pulse/s	0.0 pulse/s
Driver Unit Conversion Numerator	1 pulse	1 pulse
Driver Unit Conversion Denominator	1 pulse	1 pulse
Limit Parameter	Set Limit Parameter	
Torque Limit Maximum Value	1000.0 %	1000.0 %
Negative Direction Torque Limit Initial	300.0 %	300.0 %
Positive Direction Torque Limit Initial	300.0 %	300.0 %
Upper Limit Signal		
Signal		
Target		
Signal Detection Method	0:Detection at TRUE	0:Detection at TRUE
Compensation Time	0.0 s	0.0 s

2. Enter each item of the machine components.

Electronic Gear Setting Axis0001

Entry

Select the machine components, and enter the machine data to automatically set the axis parameters (position command unit, driver unit conversion numerator and driver unit conversion denominator).

Machine Components : Ball Screw, Horizontal

Position Command Unit um

Lead of Ball Screw (PB) 10000 [um]

Reduction Ratio (NL/NM) = 1 / 1

Calculate reduction ratio by teeth or diameters Reduction Ratio Setting

Encoder Resolution 67108864 [pulse/rev]

Setting Range
0.00000000000001[um] to 9999999999.9999[um]

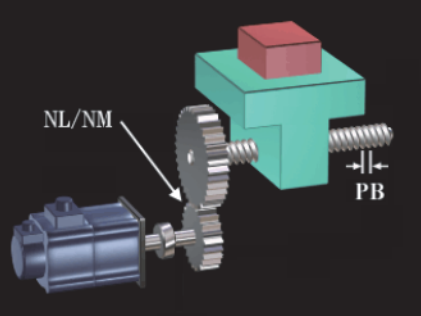

Calculate Axis Parameters

Calculation Result

Axis Parameters	Position Command Unit	
	Driver Unit Conversion Numerator	
	Driver Unit Conversion Denominator	

Movement Amount per Driver Unit Command

* The electronic gear on driver side is calculated as 1:1.

As a result of calculation, no error occurs in the movement amount.

Applying the calculation result above,
the error for every 0.0 [um] (movement amount) you perform is about 0.0 [um] Error Calculation

OK Cancel

The following is the setting example in this guide.

Item	Setting value
Position Command Unit	um ^{*1}
Lead of Ball Screw (PB)	10000.0

*1 um indicates micrometer (μm).

3. Click the "Reduction Ratio Setting" button to open the "Reduction Ratio Setting" window.

4. Set the number of teeth and click the [OK] button.

The following table lists the settings.

Item	Setting value
Teeth Z2	2
Teeth Z1	1

- Click the [Calculate Axis Parameters] button to display the calculation result. Check the calculation result, and click the [OK] button.

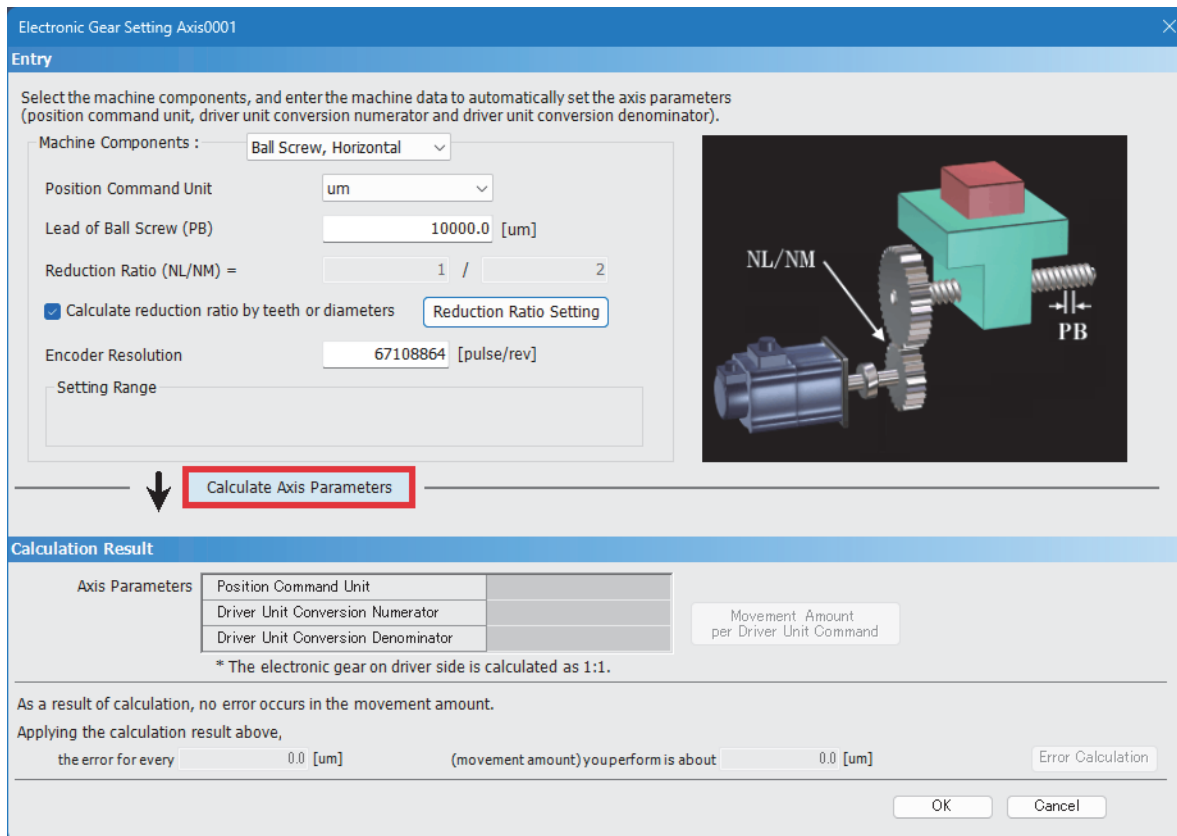

- When the confirmation message appears, click the [Yes] button. The calculation result is reflected in the axis parameters.

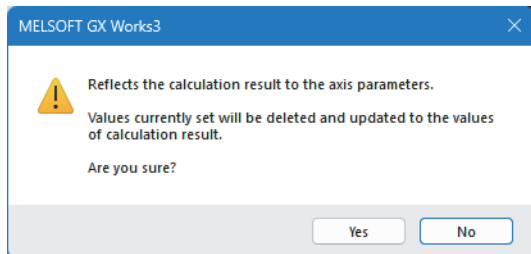

Reflecting axis parameters

After setting each item, click the [Apply] button to fix the parameters.

The screenshot shows the 'Axis Parameter Setting' software interface. On the left is a tree view of 'Setting Item List' with categories like 'Real Drive Axis', 'Axis Information', 'Basic Parameter', 'Object Data', 'Limit Parameter', 'Velocity Limit', 'Homing', 'Stop', 'Stroke Limit', and 'Driver'. The main area displays a table of parameters for two axes, Axis0001 and Axis0002. Below the table is an 'Explanation' section for the 'Axis.Pr.Drive_UnitConvRatioNum' parameter, which explains how to calculate the conversion ratio based on target position and driver unit conversion. At the bottom right, the 'Apply' button is highlighted with a red box.

Item	Axis0001	Axis0002
Axis Information	Set Axis Information	
Axis No.	1	2
Basic Parameter	Set Basic Parameter	
Station Address Setting	192.168.4.1	192.168.4.2
Axis Type Setting	0:Real Drive Axis	0:Real Drive Axis
Axis Emulation Enabled	0:Disabled	0:Disabled
Control Cycle Setting	0:Automatic setting	0:Automatic setting
Object Data		
Absolute Position Control	-1:Automatic Setting (Acquire)	-1:Automatic Setting (Acquire)
Current Position Restore	-1:Automatic judgement	-1:Automatic judgement
Ring Counter Enabled Setting	0:Disabled	0:Disabled
Ring Counter Upper Limit	10000000000.0 um	10000000000.0 um
Ring Counter Lower Limit	-10000000000.0 um	-10000000000.0 um
Position Command Unit	um	um
Position Command Unit		
Velocity Command Unit	U/s	U/s

Explanation

<Axis Parameter>
 Axis.Pr.Drive_UnitConvRatioNum
 Set the numerator to convert the command unit of the motion system to that of the driver.

[Real Drive Axis]
 Target Position Inside Motion System [controller unit] x Driver Unit Conversion Numerator / Driver Unit Conversion Denominator = Target Position Inside Driver [driver unit]
 Please set corresponding values, e.g. the resolution per motor revolution as the driver unit conversion numerator and the movement amount at that point in controller unit as the driver unit conversion denominator.

Restore the Default Settings

Apply

Axes group settings

An axes group is used for multiple axes control such as linear interpolation and circular interpolation.

An axes group does not need to be created for axes used for synchronous control.

In the two-axis system in this guide, the X axis (Axis0001) and Y axis (Axis0002) are registered as an axis group.

Axes group

1. Right-click "Axes Group" in the Navigation window, and select "Add New Data".

Navigation window ⇒ [Motion Setting] ⇒ [Axes Group]

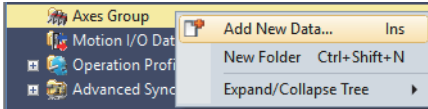

2. Enter "Data Name", the "Axes Group No.", and click the [OK] button.

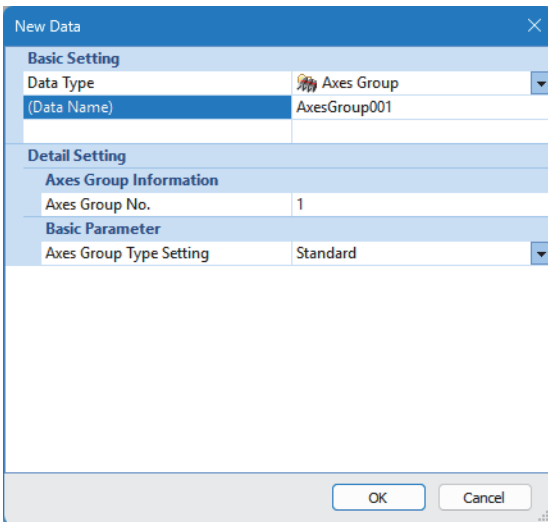

The following is the setting example in this guide.

Setting item	Setting value
Data Name	AxesGroup001
Axes Group No.	1

3. The "Axes Group Setting" window is displayed. Set the axis group parameters of AxesGroup001.

Navigation window ⇒ [Motion Setting] ⇒ [Axes Group] ⇒ double-click AxesGroup001.

- Axes group configuration axis setting example

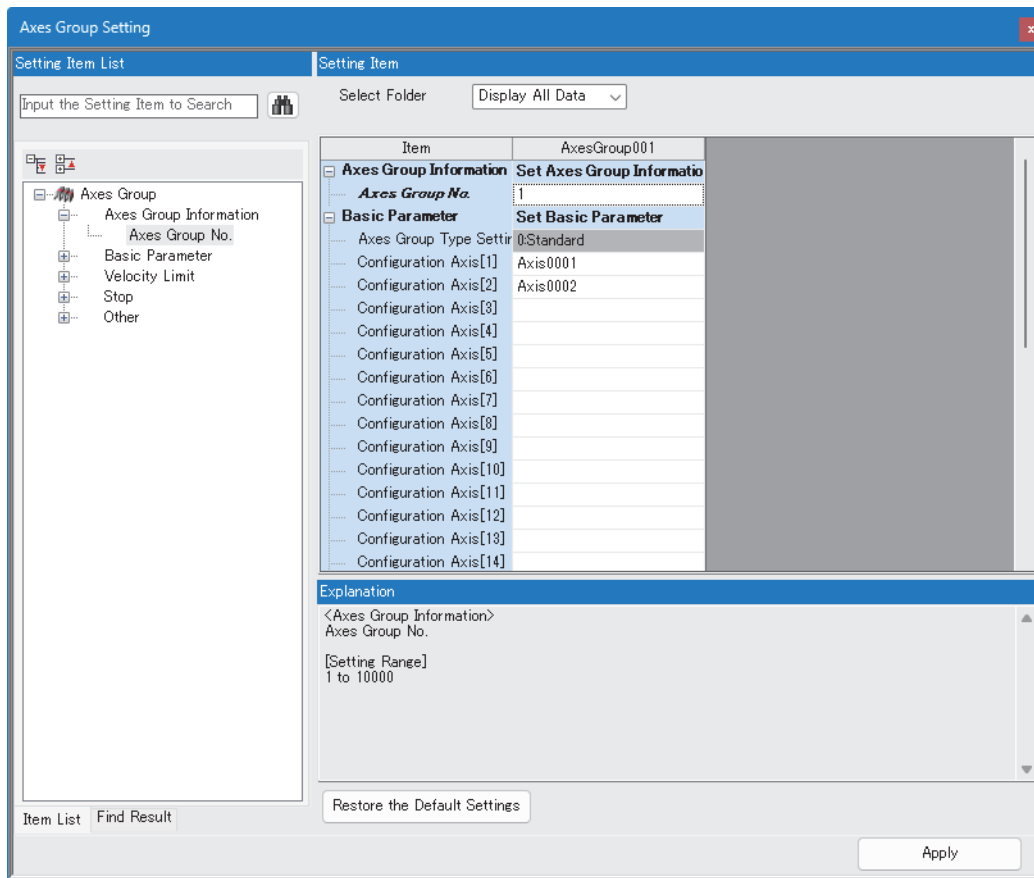

Item	Setting value
Configuration Axis[1]	Axis0001
Configuration Axis[2]	Axis0002

• Axes group units setting example

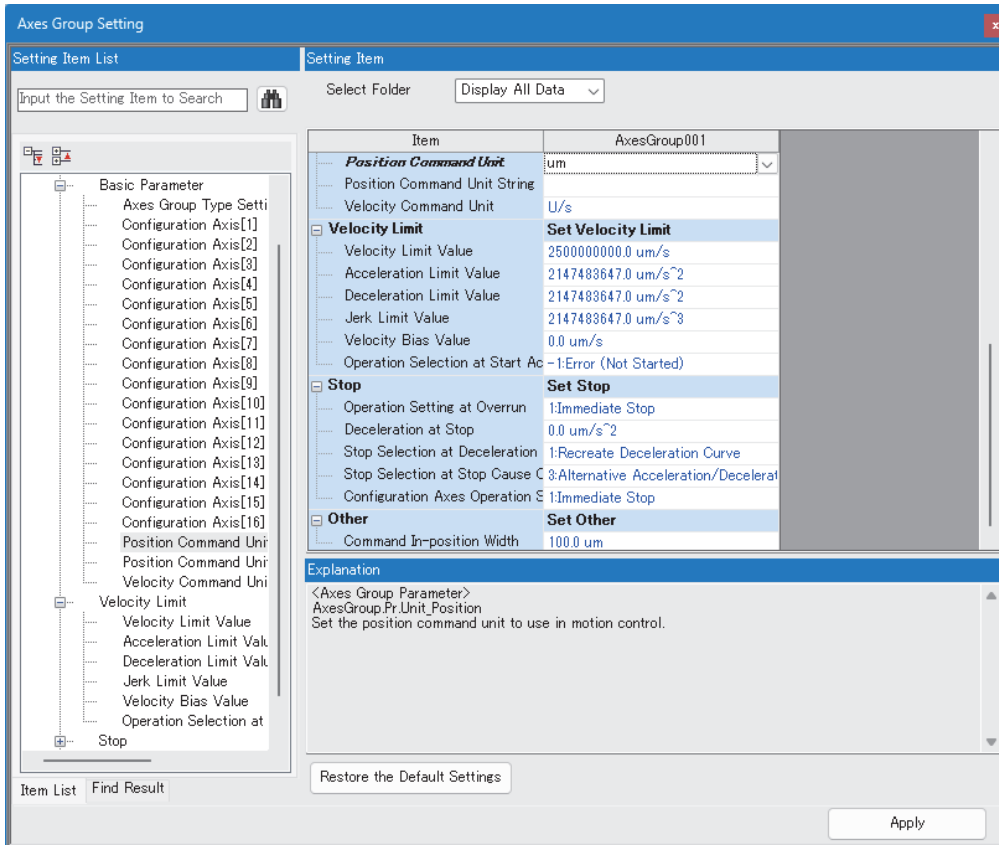

Item	Setting value
Position Command Unit	um*1

*1 um indicates micrometer (μm).

4. After setting the items for each axes group, click the [Apply] button to fix the axes group parameter setting.

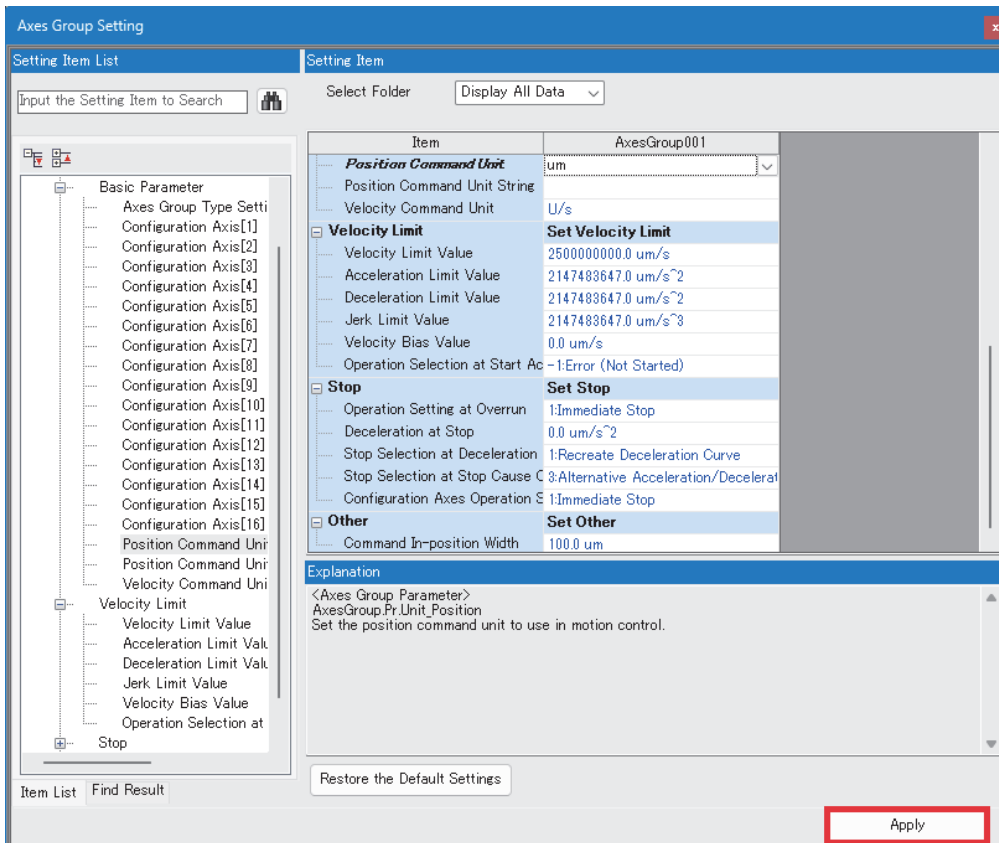

3.6 Saving a Project

Save the created project.

1. In the engineering tool, select [Project] ⇒ [Save as] on the menu bar to display the "Save as" window. Enter a file name, and click the [Save] button.

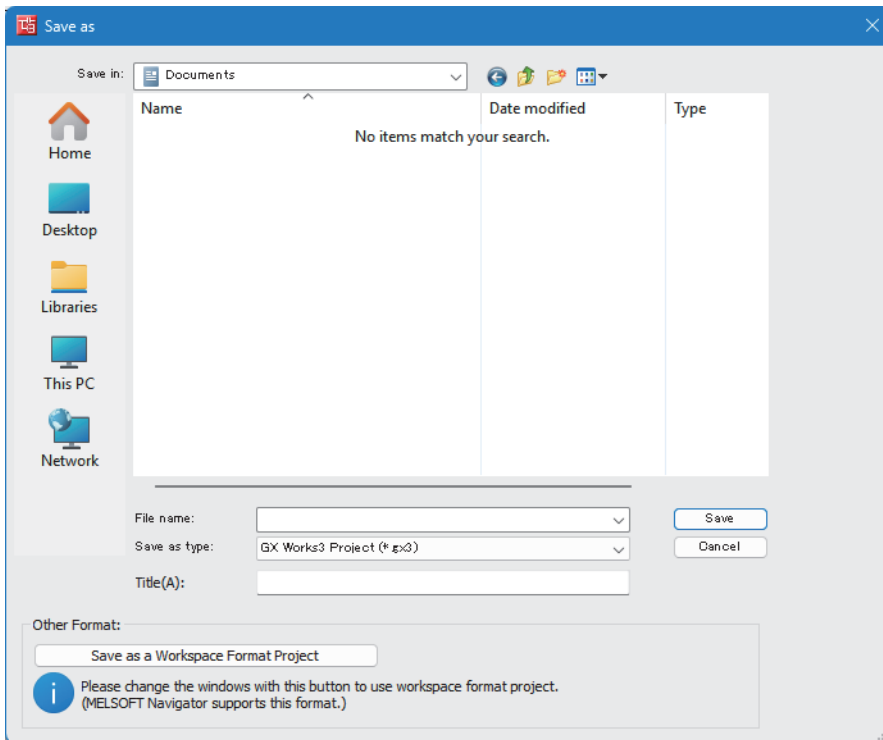

3.7 Writing to the Controller

After writing the module parameters to the controller, reset it and turn the power on again.

Operating procedure

1. Select [Online] ⇨ [Write to PLC] on the menu bar to display the "Online Data Operation" window. Check the items to be written on the window, and click the [Execute] button.

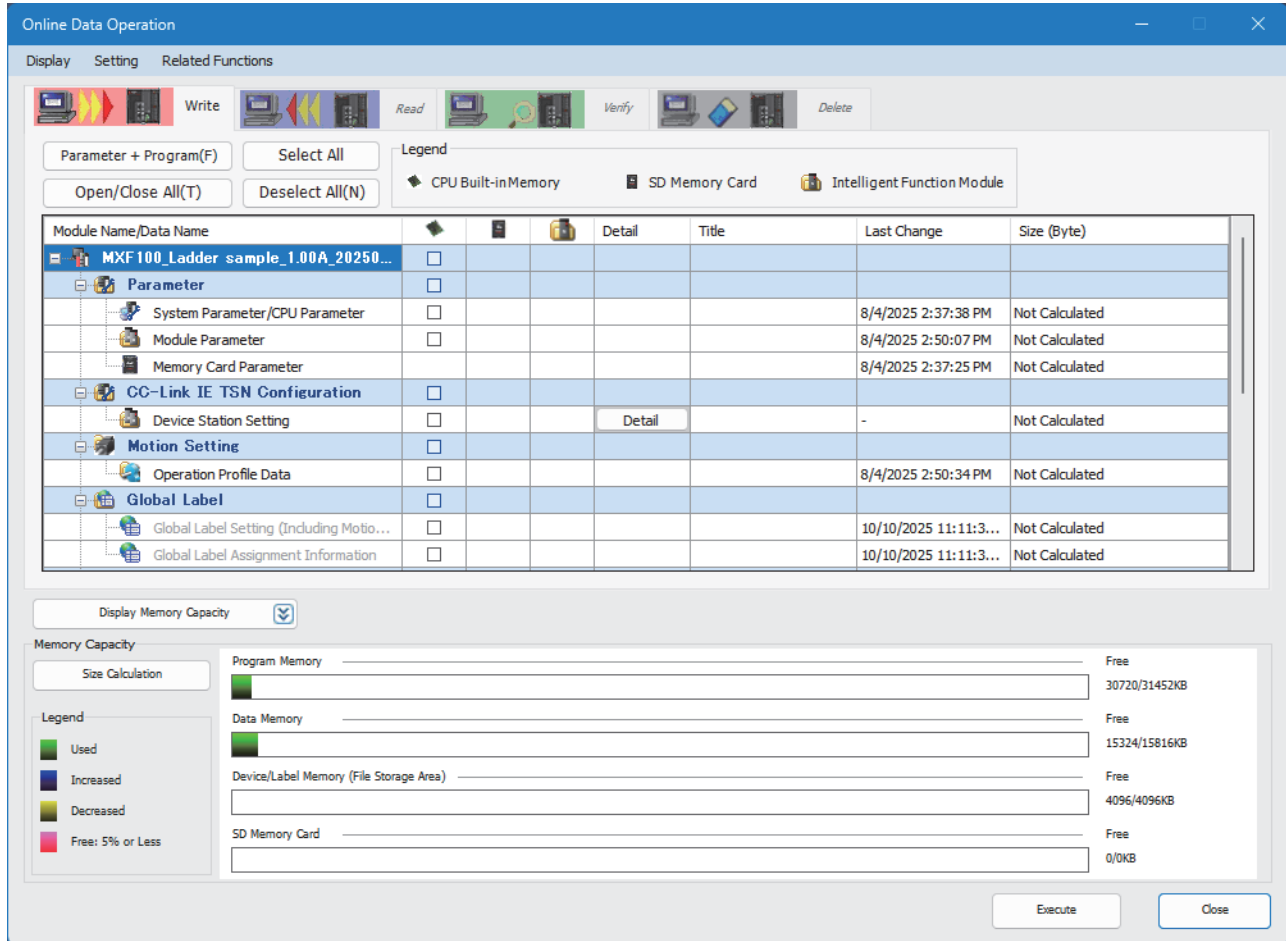

2. The parameters are written to the controller.
3. When the writing is complete, a completion message is displayed. Click the [OK] button.
Turn the controller power on again and confirm that no error occurs. Errors can be checked on the LED indicator of the controller or the system monitor of the engineering tool.

4 PROGRAM EXAMPLES

This chapter uses the ladder diagram.

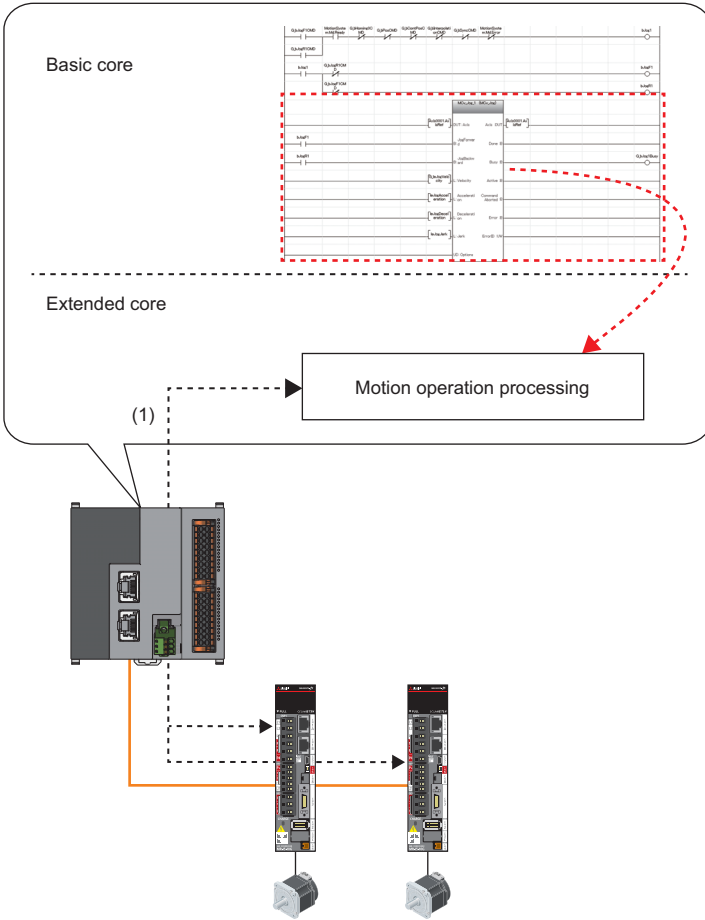

(1) I/O processing of motion operation

Point

When applying the sample program to an actual system, ensure the applicability and confirm that it will not cause system control problems.
Consider and add interlock conditions according to the system.

4.1 Creation Procedure for Controller Programs

The engineering tool is used to create a program for a controller.

Creating a program block

1. In the navigation window of the engineering tool, right-click "Program" ⇒ "Program execution type ("Scan" in this example)", and select "Add New Data".

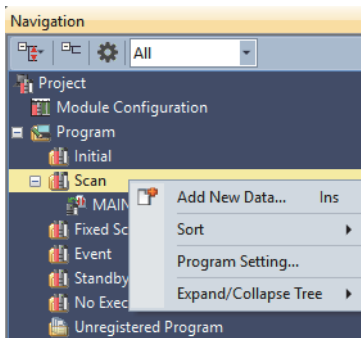

2. The "New Data" window is displayed. Set the data name, the program language, and the program file for add destination. Then, click the [OK] button. (Setting example: ServoON_Jog)

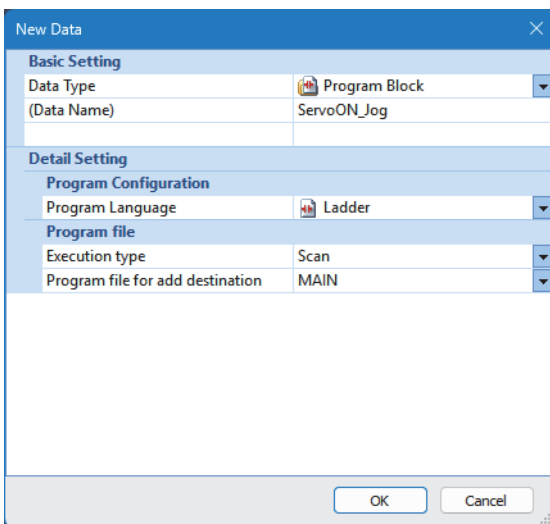

3. A program block is added to the navigation window.

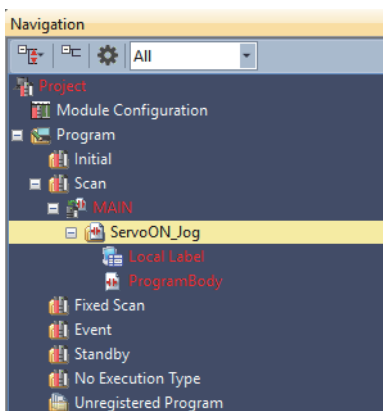

Program execution types

The following table lists the five program execution types available.

Execution type	Description
Initial	This program is executed only once when the controller status is changed from the power-on to RUN or from STOP (PAUSE) to RUN.
Scan	This type of program is executed only once per scan. The execution starts from the next scan right after the initial execution type program is executed.
Fixed scan	This is an interrupt program which is executed at a specified time interval. Different from a normal interrupt program, this type of program does not require the interrupt pointer (I) or IRET instruction and is executed for each program file unit.
Event	This type of program starts execution when triggered by a specified event.
Standby	This type of program is executed only when its execution is requested.

To set the execution type, perform the following operations in the navigation window.

The set execution type will be applied to "Program Setting" in "CPU Parameter".

- Right-click on a target program in the navigation window, and select [Register Program] from the shortcut menu.
- Drag and drop the program onto the target execution type.

How to input an FB

This section describes the procedure for creating a program using the JOG operation FB (MCv_Jog) as an example.

Preparing labels

Prepare labels for input/output signals of the FB. This example uses labels for the Velocity, Acceleration, Deceleration, and Jerk inputs of MCv_Jog. When registering a new label, consider whether the label is registered as a global label or a local label.

Ex.

The labels for JOG command and JOG velocity are registered as global labels.

JOG velocity is registered as a global label considering that it will be operated from an external device such as a GOT (HMI).

The labels for JOG acceleration, JOG deceleration, and JOG jerk are registered as local labels of the ServoON_Jog program created in Creating a program block ( Page 56 Creating a program block) since these labels are only used within this program.

For naming rules for labels, refer to the following.

 Page 62 Naming rules for labels

Global labels

	Label Name	Data Type		Class	English(Display Target)
1	G_bJogF1CMD	Bit	...	VAR_GLOBAL	JOG Positive rotation command Axis0001
2	G_bJogR1CMD	Bit	...	VAR_GLOBAL	JOG Reverse rotation command Axis0001
3	G_bJogI Busy	Bit	...	VAR_GLOBAL	JOG operation in progress Axis0001
4	G_leJogVelocity	FLOAT [Double Precision]	...	VAR_GLOBAL	JOG Velocity
5					

Local labels

	Label Name	Data Type		Class	English(Display Target)
1	leJogAcceleration	FLOAT [Double Precision]	...	VAR	JOG acceleration
2	leJogDeceleration	FLOAT [Double Precision]	...	VAR	JOG acceleration
3	leJogJerk	FLOAT [Double Precision]	...	VAR	JOG jerk
4					

Inputting an FB

1. Click the [POU List] tab in the Element Selection window and select "Motion Control Function/Function Block" ⇨ "Administrative", "Motion - Individual", or "General FB" to display the motion module FB library list.

The FB for JOG operation (MCv_Jog) is located in the "Motion - Individual" tree.

FBs are classified into the following three groups.

Group	Description
Administrative	A motion control FB that takes an axis or an axes group for the argument and does not change the axis status or the axes group status by execution (There are some exceptions.)
Motion - Individual	A motion control FB that takes an axis or an axes group for the argument and changes the axis status or the axes status by execution.
General FB	A motion control FB that does not take an axis or an axes group for the argument

2. Drag and drop the FB to use (MCv_Jog) onto the program editor.

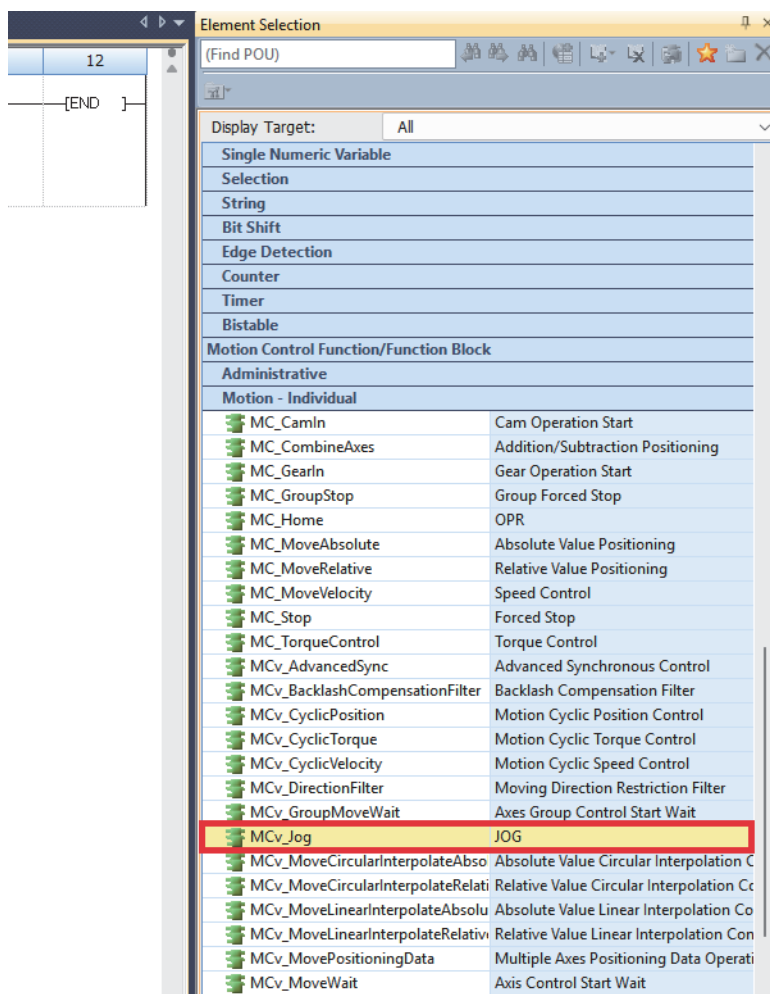

3. Enter the FB label name, registered destination, and comments if necessary, and click the [OK] button. This example uses all the initial settings.

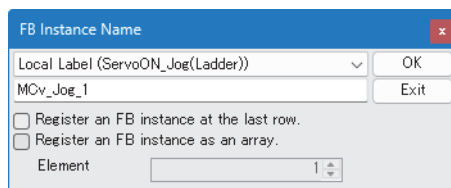

4. The FBs are assigned in the ladder editor.

Write	1	2	3	4	5	6	7	8	9	10	11	12
1						MCv_Jog_1 (MCv_Jog) JOG operation FB1 Axis001						
2						DUT: Axis	Axis :DUT					
3						Axis information	Axis information					
4						B: JogForward	Done :B					
5						Positive rotation JOG command	Execution completion					
6						B: JogBackward	Busy :B					
						Reverse rotation JOG command	Executing					
						L: Velocity	Active :B					
						Velocity	Controlling					
						L: Acceleration	CommandAborted :B					
						Acceleration	Abortion of execution					



Clicking [Display] ⇒ [Comment Display] from the menu in the engineering tool switches whether the device comments display/hide.

Inputting I/O signals

Double-click the cell on the work window to be assigned and enter the label into the circuit input dialog.

■ AxisRef type structure

This section describes how to input the AxisRef type structure, which is axis information for axis 1, into the input variable Axis.

1. Enter "ax" into the circuit input dialog to display the registered labels.

Write	1	2	3	4	5	6	7	8	9	10	11	12
1						MCv_Jog_1 (MCv_Jog) JOG operation FB1 Axis001						
2						DUT: Axis	Axis :DUT					
3						Axis information	Axis information					
4						B: JogForward	Busy :B					
5						Reverse rotation JOG command	Executing					
						L: Velocity	Active :B					
						Velocity	Controlling					

AX

OK Cancel Extd Dspl

- AXIS_REF AXIS_REF(1..5) Axis number setting
- AxesGroup001 AXES_GROUP
- Axis0001 AXIS_REAL
- Axis0002 AXIS_REAL

[Setting...](#)

Global label and local label

Enter the global label "G_bJogF1CMD" into the "JogForward" input.

1. When "G_b" is entered into the circuit input dialog, the registered labels will be displayed. Select "G_bJogF1CMD".

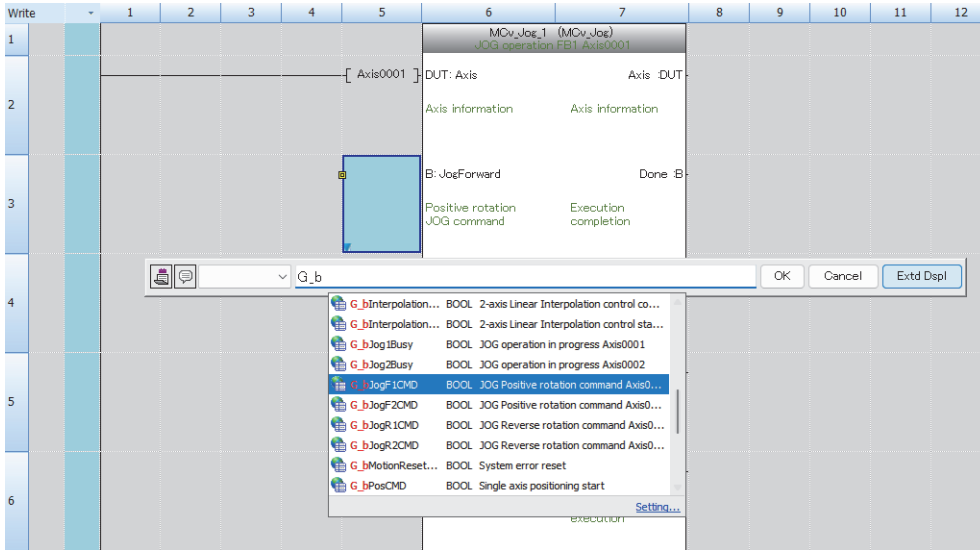

2. Using the same procedure, enter labels for the JogBackward, Velocity, Acceleration, Deceleration, Jerk, and Busy signals.

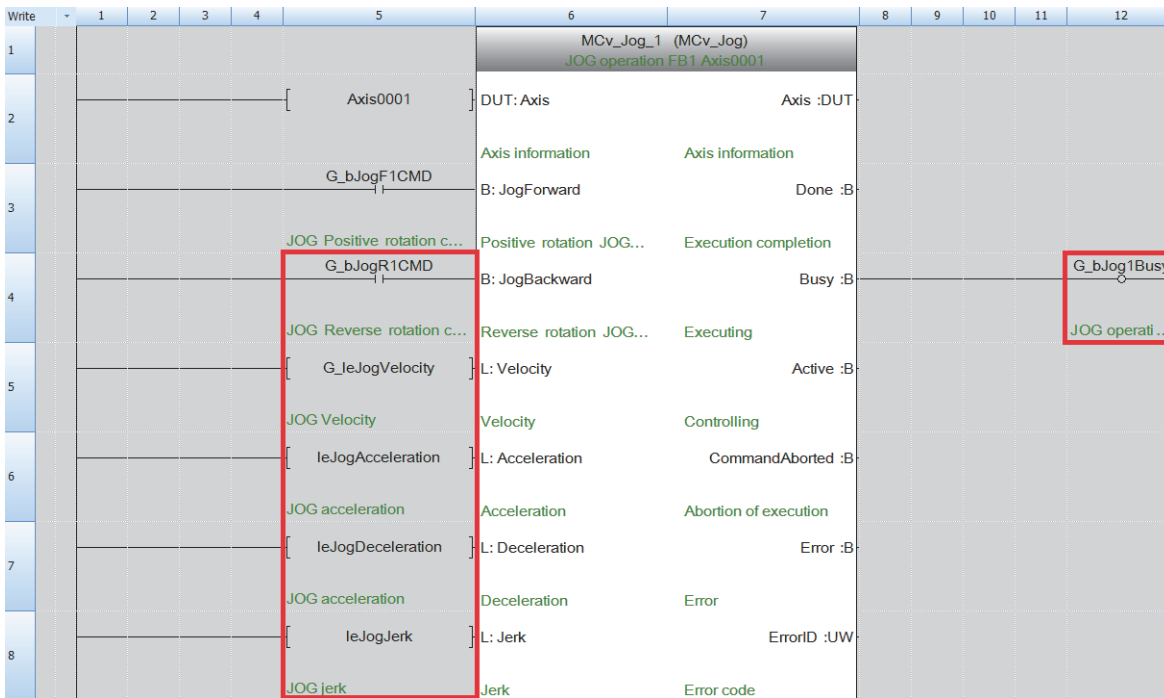

4.2 Label

Naming rules for labels

This guide uses the following prefix rules for labels to distinguish their data type.

Data type		Value range	Prefix	
			Local	Global
Bit	BOOL	FALSE, TRUE	b	G_b
Word [unsigned]/bit string [16 bits]	WORD	0 to 65535	u	G_u
Double word [unsigned]/bit string [32 bits]	DWORD	0 to 4294967295	ud	G_ud
Word [signed]	INT	-32768 to 32767	w	G_w
Double word [signed]	DINT	-2147483648 to 2147483647	d	G_d
Single-precision real number	REAL	-2^{128} to -2^{-126} , 0, 2^{-126} to 2^{128}	e	G_e
Double-precision real number	LREAL	-2^{1024} to -2^{-1022} , 0, 2^{-1022} to 2^{1024}	le	G_le
Time	TIME	T#-24d20h31m23s648ms to T#24d20h31m23s647ms	tm	G_tm
Timer	TIMER	TIMER structure • S: contact • C: coil • N: current value	td	G_td

Ex.

For local labels

Data type	Label
Bit	bMoveCMD
Double-precision real number	lePosition
Word [signed] + array	wAxes[16]
Timer	tdTimer1

Ex.

For global labels

Data type	Label
Bit	G_bJogF1
Double-precision real number	G_leVelocity

Global label list

The following shows setting examples for the global labels in the sample program.

For the local labels, refer to each program.

Global label setting

The following table lists the global label settings.

	Label Name	Data Type	English(Display Target)	Access from External Device
1	G_bSRVONCMD	Bit	... Servo ON	<input type="checkbox"/>
2	G_bSRVOFF	Bit	... Servo OFF	<input type="checkbox"/>
3	G_bHomingCMD	Bit(1..3)	... Homing Command	<input type="checkbox"/>
4	G_bHoming0CMD	Bit	... Homing Command	<input type="checkbox"/>
5	G_bHoming1CMD	Bit	... Homing Command Axis0001	<input type="checkbox"/>
6	G_bHoming2CMD	Bit	... Homing Command Axis0002	<input type="checkbox"/>
7	G_bHoming3CMD	Bit	... Homing Command Axis0003	<input type="checkbox"/>
8	G_bHomingReq	Bit(1..3)	... Homing Request	<input type="checkbox"/>
9	G_bHoming1Req	Bit	... Homing Request Axis0001	<input type="checkbox"/>
10	G_bHoming2Req	Bit	... Homing Request Axis0002	<input type="checkbox"/>
11	G_bHoming3Req	Bit	... Homing Request Axis0003	<input type="checkbox"/>
12	AXIS_REF	AXIS_REF(1..5)	... Axis number setting	<input type="checkbox"/>
13	G_bPosCMD	Bit	... Single axis positioning start	<input type="checkbox"/>
14	G_bPosReq	Bit	... Single axis positioning start request	<input type="checkbox"/>
15	G_bContPosCMD	Bit	... Single axis continuous positioning start	<input type="checkbox"/>
16	G_bContPosReq	Bit	... Single axis continuous positioning start request	<input type="checkbox"/>
17	G_bInterpolationCMD	Bit	... 2-axis Linear Interpolation control start	<input type="checkbox"/>
18	G_bInterpolationReq	Bit	... 2-axis Linear Interpolation control start request	<input type="checkbox"/>
19	G_bSyncCMD	Bit	... Synchronous control start	<input type="checkbox"/>
20	G_bSyncReq	Bit	... Synchronous control start request	<input type="checkbox"/>
21	G_bResetCMD	Bit	... Error reset	<input type="checkbox"/>
22	G_bMotionResetCMD	Bit	... System error reset	<input type="checkbox"/>
23	G_bJogF1CMD	Bit	... JOG Positive rotation command Axis0001	<input type="checkbox"/>
24	G_bJogR1CMD	Bit	... JOG Reverse rotation command Axis0001	<input type="checkbox"/>
25	G_bJogF2CMD	Bit	... JOG Positive rotation command Axis0002	<input type="checkbox"/>
26	G_bJogR2CMD	Bit	... JOG Reverse rotation command Axis0002	<input type="checkbox"/>
27	G_bJog1Busy	Bit	... JOG operation in progress Axis0001	<input type="checkbox"/>
28	G_bJog2Busy	Bit	... JOG operation in progress Axis0002	<input type="checkbox"/>
29	G_leJogVelocity	FLOAT [Double Precision]	... JOG Velocity	<input type="checkbox"/>
30	G_bHoming1Done	Bit	... Homing complete Axis0001	<input type="checkbox"/>
31	G_bHoming2Done	Bit	... Homing complete Axis0002	<input type="checkbox"/>
32	G_bHoming3Done	Bit	... Homing complete Axis0003	<input type="checkbox"/>
33	G_bHoming4Done	Bit	... Homing complete VirtualAxis0001	<input type="checkbox"/>
34	G_bHoming5Done	Bit	... Homing complete LinkAxis0001	<input type="checkbox"/>
35	G_bPosDone	Bit	... Single axis positioning complete	<input type="checkbox"/>
36	G_bContPosDone	Bit	... Single axis continuous positioning complete	<input type="checkbox"/>
37	G_bInterpolationDone	Bit	... 2-axis Linear Interpolation control complete	<input type="checkbox"/>
38	G_bSyncDone	Bit	... Synchronous control complete	<input type="checkbox"/>
39	G_bStopSignalX	Bit	... Stop command Axis0001	<input checked="" type="checkbox"/>
40	G_bStopSignalY	Bit	... Stop command Axis0002	<input checked="" type="checkbox"/>

Network labels

Creating a network label enables label access to other modules on the network.
Network labels target remote stations and are registered as global labels.

Creation procedure for network labels

Operating procedure

1. Display the "Network Label Setting" window, and insert a check in "Labeling Target" for "Data Type" to be labeled.

Navigation window ⇒ "Parameter" ⇒ Controller ⇒ Module Parameter (CC-Link IE TSN port) ⇒ "Network Label Setting"

No.	IP Address	Model Name	Device Label/Structured Data Type Definition Name	Data Type	Labeling Target	Arrayed Target	Label Data Type
1	192.168.4.1	MR-J5-G	MR_J5_G_001	Entire Device	<input checked="" type="checkbox"/>	<input type="checkbox"/>	-
				RWw0	<input checked="" type="checkbox"/>	<input type="checkbox"/>	Word [Unsigned]/Bit String [16-bit] MR_J5
				RWw1	<input type="checkbox"/>	<input type="checkbox"/>	Word [Signed] MR_J5
				RWw2	<input type="checkbox"/>	<input type="checkbox"/>	Double Word [Signed] MR_J5
				RWw4	<input type="checkbox"/>	<input type="checkbox"/>	Double Word [Signed] MR_J5
				RWw6	<input type="checkbox"/>	<input type="checkbox"/>	Word [Unsigned]/Bit String [16-bit] MR_J5
				RWw7	<input type="checkbox"/>	<input type="checkbox"/>	Word [Unsigned]/Bit String [16-bit] MR_J5
				RWw8	<input type="checkbox"/>	<input type="checkbox"/>	Word [Unsigned]/Bit String [16-bit] MR_J5
				RWw9	<input type="checkbox"/>	<input type="checkbox"/>	Word [Signed] MR_J5
				RWwA	<input type="checkbox"/>	<input type="checkbox"/>	Double Word [Unsigned]/Bit String [32-bit] MR_J5
				RWwC	<input type="checkbox"/>	<input type="checkbox"/>	Word [Unsigned]/Bit String [16-bit] MR_J5
				RWwD	<input type="checkbox"/>	<input type="checkbox"/>	Word [Unsigned]/Bit String [16-bit] MR_J5
				RWwE	<input type="checkbox"/>	<input type="checkbox"/>	Word [Unsigned]/Bit String [16-bit] MR_J5
				RWwF	<input type="checkbox"/>	<input type="checkbox"/>	Word [Unsigned]/Bit String [16-bit] MR_J5
				RWw10	<input type="checkbox"/>	<input type="checkbox"/>	Word [Unsigned]/Bit String [16-bit] MR_J5
				RWw11	<input type="checkbox"/>	<input type="checkbox"/>	Word [Signed] MR_J5
				RWw0	<input type="checkbox"/>	<input type="checkbox"/>	Word [Unsigned]/Bit String [16-bit] MR_J5
				RWw1	<input type="checkbox"/>	<input type="checkbox"/>	Word [Signed] MR_16

Explanation
The I/O data exchanged between the device stations of built-in CC-Link IE TSN and the CPU module by cyclic communication can be registered as a label.
If 'Create Label' is executed, the label selected in 'Labeling Target' will be registered to the global label list (NW+Global).

[Caution]
- If 'Create Label' is executed, the all labels/structured data types created from this window last time will be deleted and new labels/structured data types will be created.
- The background of 'No.' in the window will be displayed in yellow for the device for which addition/change exists in the network configuration after creating the label last time. Please execute 'Create Label' again if necessary.
- If 'Create Label' is not executed, the edited content in this window will not be saved in the project.

Structure Array Setting... Update Network Configuration Info Create Label

2. Click the [Create Label] button.

3. Click the [Yes] button.

MELSOFT GX Works3

Start creating the label on the basis of the setting content.
Are you sure you want to continue?

Yes No

4. A list of the created network labels is displayed in Global Label.

Navigation window ⇒ "Label" ⇒ "Global Label" ⇒ "NW+Global1"

Label Name	Data Type	English(Display Target)	Access from External Device
1 MR_J5_G_001_WatchdogCounterDI1	Word [Unsigned]/Bit String [16-bit]	... RWw0	<input type="checkbox"/>
2			<input type="checkbox"/>

Point

- Set the remote station in advance in the "CC-Link IE TSN Configuration" window.
- Right-click in the "Network Label Setting" window and execute "Add Prefix" or "Delete Prefix" to add or delete a device label to/from the label names.

Precautions

- When the network number or network configuration setting has been changed, open the "Network Label Setting" window again or click the [Update Network Configuration Info] button and then the [Create Label] button.
- Network labels will be refreshed regardless of whether the network label checkbox is selected in the network configuration setting. Therefore, the network labels that are already created will be refreshed even if the network label checkbox in the network configuration setting is not selected. If no network label is used, delete the network labels.
- When using the network labels assigned to RY and another RY in the same word boundary, use network label.

4.3 Project Structure

Program name

The following shows the program examples created in this section.

Programs are created in the "Program" ⇒ "Scan" ⇒ "MAIN" tree.

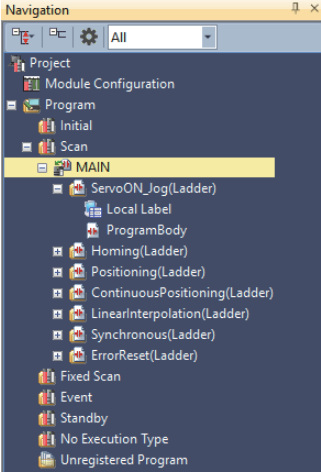
Navigation window display	Program name	Description	Reference
	ServoON_Jog	PLC READY	Page 67 PLC READY (Program Name: ServoON_Jog)
		All axes servo ON	Page 68 Servo ON (Program Name: ServoON_Jog)
		JOG operation	Page 69 JOG Operation (Program Name: ServoON_Jog)
	Homing	Homing	Page 74 OPR (Program Name: Homing)
	Positioning	Single axis positioning	Page 78 Single Axis Positioning Control (Program Name: Positioning)
	ContinuousPositioning	Single axis continuous positioning	Page 80 Single Axis Continuous Positioning (Program Name: ContinuousPosition)
	LinearInterpolation	Two-axis linear interpolation control	Page 87 Interpolation Control (Program Name: LinearInterpolation)
	Synchronous	Synchronous control	Page 98 Synchronous Control (Program Name: Synchronous)
	ErrorReset	Error reset	Page 113 Error Reset (Program Name: ErrorReset)

4.4 PLC READY (Program Name: ServoON_Jog)

This program prepares for motion control.

Program examples

After the controller is powered on, PLC READY (MotionSystem.Cd.SequenceReady) and Built-in Motion Ready (MotionSystem.Md.Ready) turn on, and then the servo-ON signal (G_bSRVONCMD) turns on.

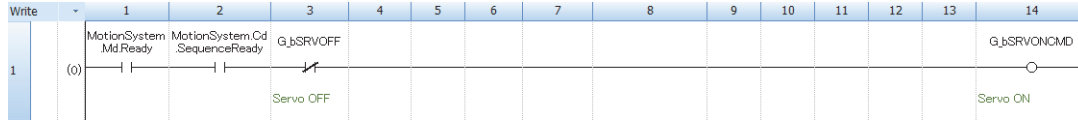

4.5 Servo ON (Program Name: ServoON_Jog)

This program performs servo ON for the real drive axes connected to the servo system.

There are two FBs that are used for servo ON: MCv_AllPower, which performs servo ON for all axes and MC_Power, which performs servo ON for each individual axis.

FBs used

Type	FB	Description
Administrative	MC_Power	Switches a specified axis to the operation available status.
	MCv_AllPower	Switches every axis to the operation available status.

Local labels

	Label Name	Data Type	Class	English(Display Target)
1	MCv_AllPower_1	MCv_AllPower	VAR	All axes servo ON FB

No.	Description
1	This label is automatically added when the user drags and drops the FB (MCv_AllPower) onto the program editor.

Program example

The servo ON signal (G_bSRVONCMD) is used as the condition for executing all axes servo ON. When executing servo OFF, turn on "G_bSRVOFF".

- All axes servo ON

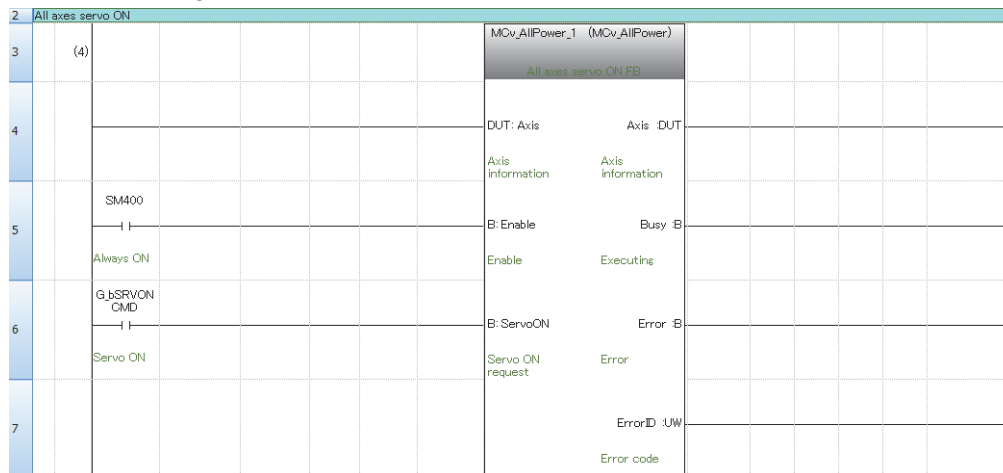

4.6 JOG Operation (Program Name: ServoON_Jog)

The servo system outputs commands to a target axis and operates the axis in a specified direction while the JOG positive/reverse rotation commands are input.

FBs used

Type	FB	Description
Motion	MCv_Jog	Executes JOG operation according to the command velocity.

Acceleration/deceleration processing function

The acceleration/deceleration function is used to adjust the acceleration/deceleration curve of the motion control according to the machine.

■Overview

There are two acceleration/deceleration methods.

Acceleration/deceleration method	Description
Acceleration/deceleration specification method (Initial value)	Accelerates/decelerates the axis by the acceleration, deceleration, and jerk values specified in the FB.
Acceleration/deceleration time-fixed method	Accelerates/decelerates the axis based on the time specified in the FB regardless of the velocity.

■Setting method

The acceleration/deceleration method can be set with the Options input of operation motion control FBs, such as MCv_Jog.

Bit	Name	Description
0 to 2	Acceleration/deceleration method setting	0: Acceleration/deceleration specification method (mcAccDec) 1: Acceleration/deceleration time-fixed method (mcFixedTime)
3 to 31		The function varies depending on the FB.

■Acceleration/deceleration specification method

Select "0: Acceleration/deceleration specification method (mcAccDec)" in Acceleration/deceleration method setting (Options: Bit 0 to 2) of the FB, and set the Acceleration, Deceleration, and Jerk inputs.

Trapezoidal acceleration/deceleration	Jerk acceleration/deceleration
<p>When "0.0" is set for the Jerk input of the FB, the operation is referred to as trapezoidal acceleration/deceleration. The velocity creates a trapezoidal shape.</p>	<p>When a value other than "0.0" is set for the Jerk input of the FB, the operation is referred to as jerk acceleration/deceleration. The velocity creates an S-curve shape.</p>

■Acceleration/deceleration time-fixed method

Select "1: Acceleration/deceleration time-fixed method (mcFixedTime)" in Acceleration/deceleration method setting (Options: Bit 0 to 2) of the FB, and set the acceleration time in the Acceleration input. The Deceleration and Jerk inputs are not used.

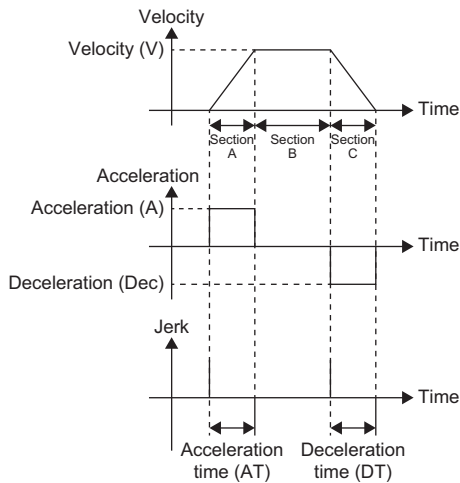

■FB input variables

The following table explains each FB input variable.

Input variable	Name	Description
Velocity	Velocity	Specify the velocity used for the FB.
Acceleration	Acceleration	Specify the acceleration used for the FB. <ul style="list-style-type: none"> The unit is [U/s²] when the method is set to "0: Acceleration/deceleration specification method (mcAccDec)". The unit is [s] when the method is set to "1: Acceleration/deceleration time-fixed method (mcFixedTime)".
Deceleration	Deceleration	Specify the deceleration used for the FB. <ul style="list-style-type: none"> The unit is [U/s²] when the method is set to "0: Acceleration/deceleration specification method (mcAccDec)". Not used when the method is set to "1: Acceleration/deceleration time-fixed method (mcFixedTime)".
Jerk	Jerk	Specify the jerk used for the FB. <ul style="list-style-type: none"> The unit is [U/s³] when the method is set to "0: Acceleration/deceleration specification method (mcAccDec)". Not used when the method is set to "1: Acceleration/deceleration time-fixed method (mcFixedTime)".
Options	Options	Specify the acceleration/deceleration method using Acceleration/deceleration method setting (Bit 0 to 2). <ul style="list-style-type: none"> 0: Acceleration/deceleration specification method (mcAccDec) 1: Acceleration/deceleration time-fixed method (mcFixedTime)

Point

When "0: Acceleration/deceleration specification method (mcAccDec)" is selected, the values for Acceleration and Deceleration are calculated using the acceleration/deceleration time as follows.

<For velocity V [U/s], acceleration time [s], and deceleration time [s]>

Velocity := (velocity V);

Acceleration := (velocity V/acceleration time);

Deceleration := (velocity V/deceleration time);

Options := (mcAccDec);

Local labels

	Label Name	Data Type	Class	English(Display Target)
1	MCv_AllPower_1	MCv_AllPower	VAR	All axes servo ON FB
2	MCv_Jog_1	MCv_Jog	VAR	JOG operation FB1 Axis0001
3	MCv_Jog_2	MCv_Jog	VAR	JOG operation FB1 Axis0002
4	bJog1	Bit	VAR	JOG Operation FB1 Axis0001
5	bJog2	Bit	VAR	JOG Operation FB1 Axis0002
6	bJogF1	Bit	VAR	JOG Positive rotation command Axis0001
7	bJogR1	Bit	VAR	JOG Reverse rotation command Axis0001
8	bJogF2	Bit	VAR	JOG Positive rotation command Axis0002
9	bJogR2	Bit	VAR	JOG Reverse rotation command Axis0002
10	leJogAcceleration	FLOAT [Double Precision]	VAR	JOG acceleration
11	leJogDeceleration	FLOAT [Double Precision]	VAR	JOG acceleration
12	leJogJerk	FLOAT [Double Precision]	VAR	JOG jerk

No.	Description
1	This label is registered as follows.  Page 68 Servo ON (Program Name: ServoON_Jog)
2, 3	These labels are automatically added when the user drags and drops the FB (MCv_Jog) onto the program editor.
4 to 12	These labels are registered manually.

Program example

Inline structured text is used to store values for the JOG velocity, acceleration, deceleration, and jerk.

The labels for the JOG positive and reverse rotation commands are input to the corresponding command inputs (JogForward and JogBackward) of the FB (MCv_Jog).

The interlock conditions are added to prevent execution of the JOG operation while other programs are running.

Start signal

Signal name	Label name	
	Axis0001	Axis0002
JOG positive rotation command	G_bJogF1CMD	G_bJogF2CMD
JOG reverse rotation command	G_bJogR1CMD	G_bJogR2CMD

• Data setting for JOG operation, Axis0001 JOG operation

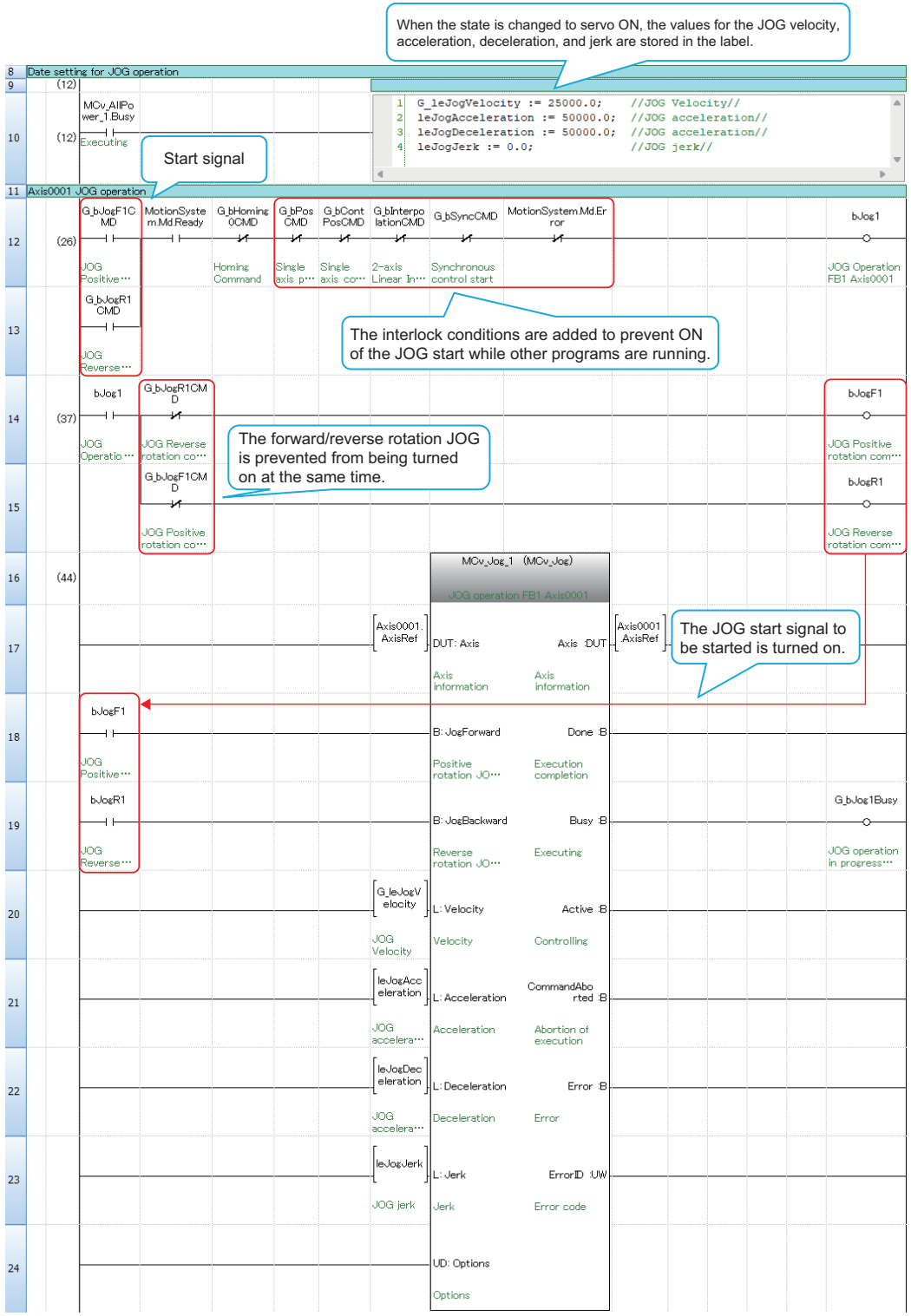

• Axis0002 JOG operation

Start signal

The configuration is the same as that of the Axis0001 program.

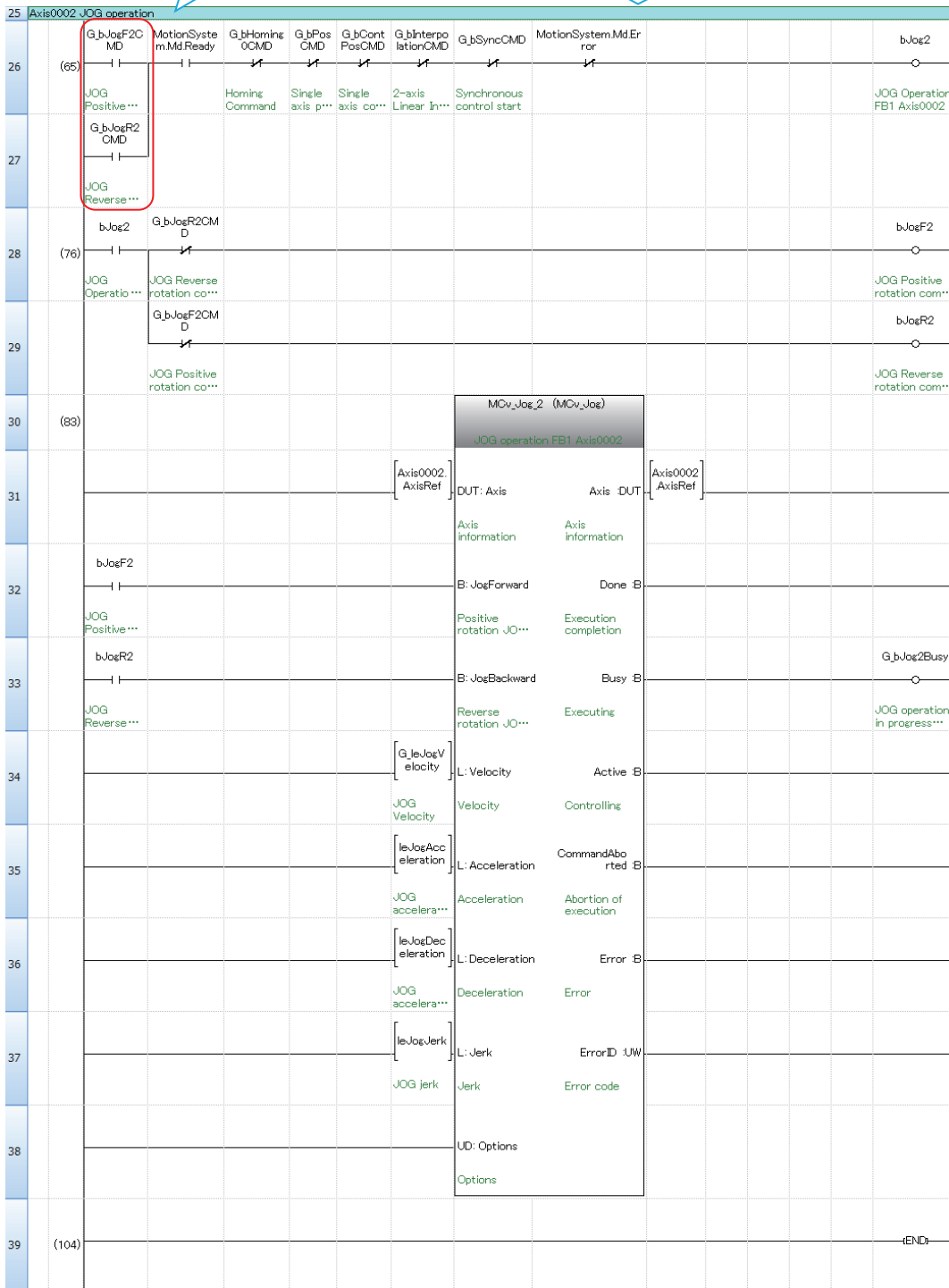

4.7 OPR (Program Name: Homing)

The homing method is set using the parameters of the servo amplifier. This section describes the data set method homing.

Overview

The data set type homing sets the current position as the home position.

Time chart of data set type homing (Method37)

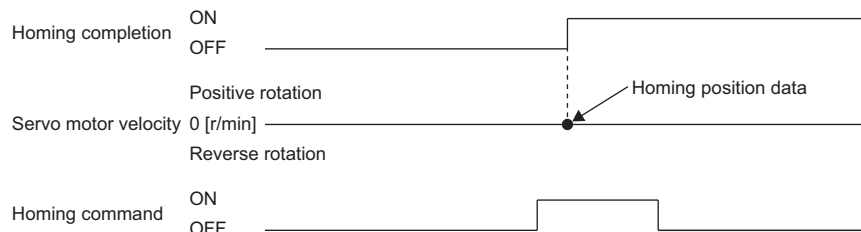

FBs used

Type	FB	Description
Motion	MC_Home	Executes OPR of the specified axis.

Local labels

No.	Label Name	Data Type	Class	English(Display Target)
1	MC_Home_0	MC_Home(1..3)	VAR	Homing FB
2	AxisArray	Word [Signed]	VAR	Axis number
3	AxisArray0	Word [Unsigned]/Bit String [16-bit]	VAR	Axis number
4	bHomingReq	Bit(1..3)	VAR	Homing Request
5	bHomingDone0	Bit(1..3)	VAR	Homing Done output
6	bHomingDone	Bit(1..3)	VAR	Homing Done output
7	bHomingError	Bit(1..3)	VAR	Homing Error output
8	Fb_RTRIG	R_TRIG	VAR	Detecting rising edge FB

No.	Description
1	These labels are automatically added when the user drags and drops the FB (MC_Home) onto the program editor.
2 to 8	These labels are registered manually.

Program example

This program executes OPR for real drive axes Axis 1 (Axis0001) and Axis 2 (Axis0002) and the virtual drive axis 1 (VirtualAxis0001). The homing request label is kept on by a self-holding circuit and is input to the Execute command (Execute) of the FB (MC_Home). The start signal is turned off when the homing completion signal (the Done output of MC_Home) is turned on or when an error occurs.

The interlock conditions are added to prevent execution of the homing while other programs are running or when a system error occurs.

Start signal

Signal name	Label name		
	Axis0001	Axis0002	VirtualAxis0001
Homing command	G_bHoming1CMD	G_bHoming2CMD	G_bHomingCMD3

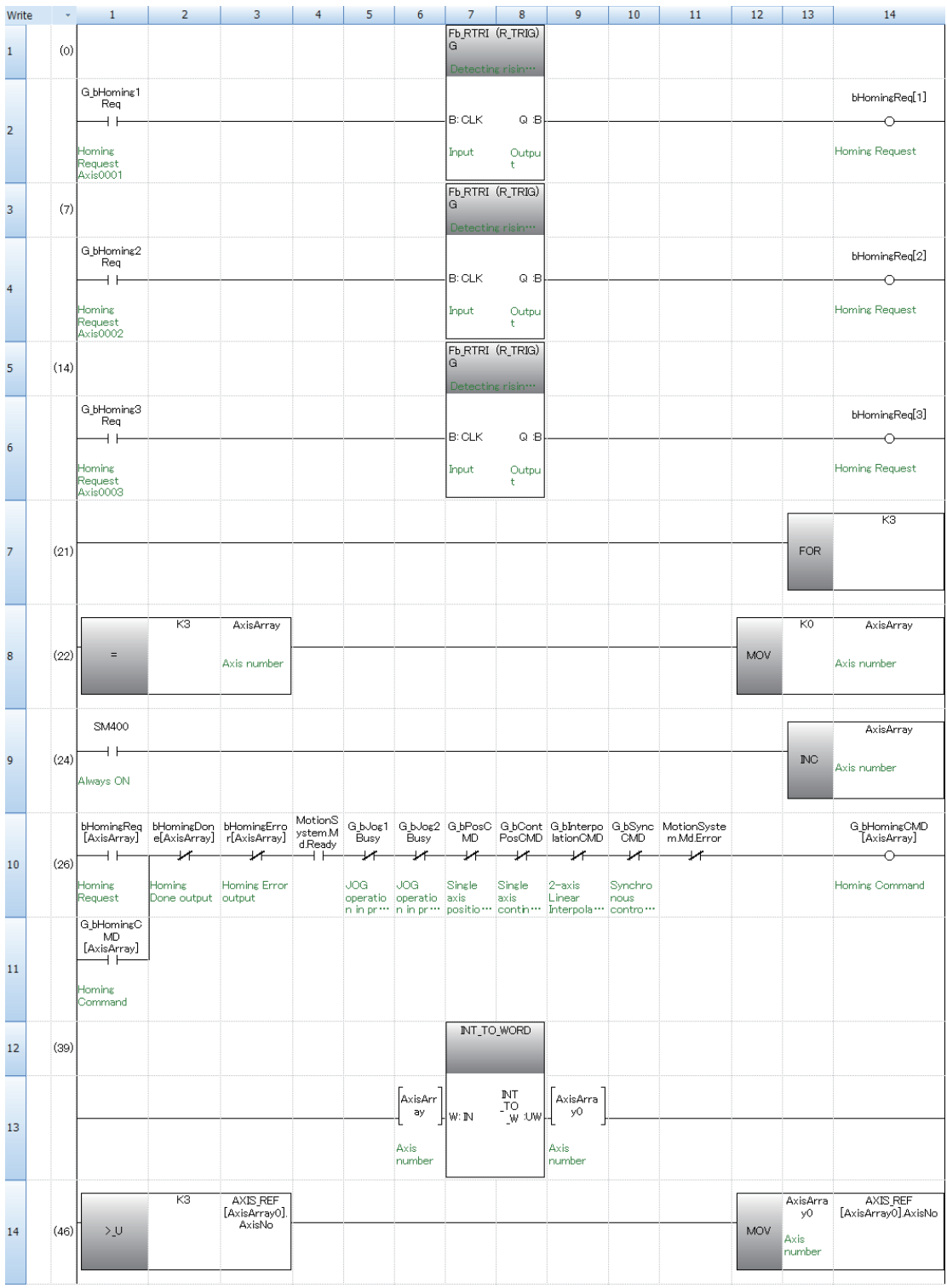

• Homing

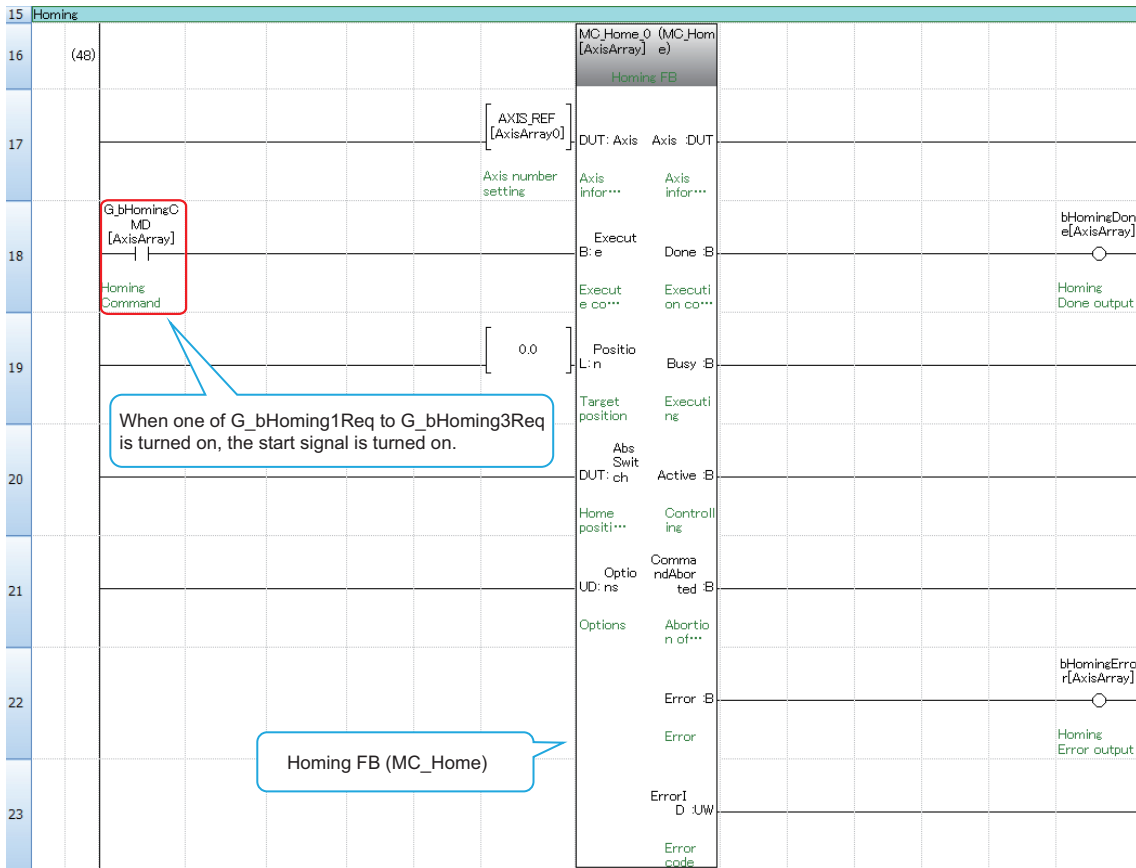

• Homing complete

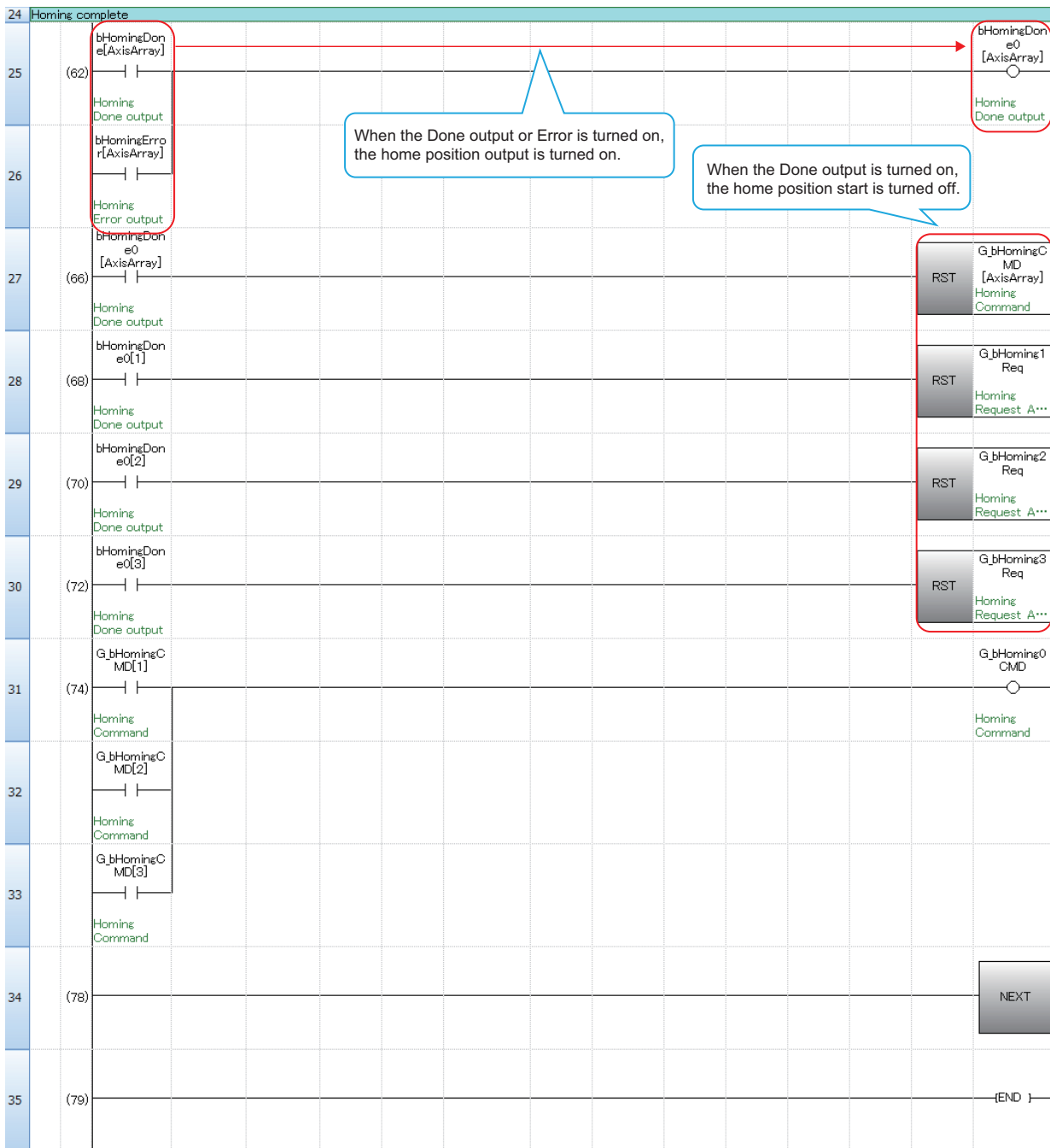

4.8 Single Axis Positioning Control (Program Name: Positioning)

Execute positioning to the specified position by using address information.

FBs used		
Type	FB	Description
Motion	MC_MoveAbsolute	Executes positioning using a specified absolute position.
	MC_MoveRelative	Executes positioning using a specified relative distance.

Local labels				
	Label Name	Data Type	Class	English(Display Target)
1	MC_MoveRelative_1	MC_MoveRelative	VAR	Relative value positioning FB
2	leDistance	FLOAT [Double Precision]	VAR	Distance
3	leVelocity	FLOAT [Double Precision]	VAR	Velocity
4	leAcceleration	FLOAT [Double Precision]	VAR	Acceleration
5	leDeceleration	FLOAT [Double Precision]	VAR	Deceleration
6	leJerk	FLOAT [Double Precision]	VAR	Jerk
7	bPosReq	Bit	VAR	Relative value positioning start request
8	bPosDone	Bit	VAR	Relative value positioning Complete
9	bDone	Bit	VAR	Relative value positioning FB Done output
10	bBusy	Bit	VAR	Relative value positioning FB Busy output
11	bError	Bit	VAR	Relative value positioning FB Error output
12	bCommandAborted	Bit	VAR	Relative value positioning FB CommandAborted output
13	Fb_RTRIG	R_TRIG	VAR	Detecting rising edge FB

No.	Description
1	This label is automatically added when the user drags and drops the FB (MC_MoveRelative) onto the program editor.
2 to 13	These labels are registered manually.

Program example

This program executes relative positioning in the following operation pattern.

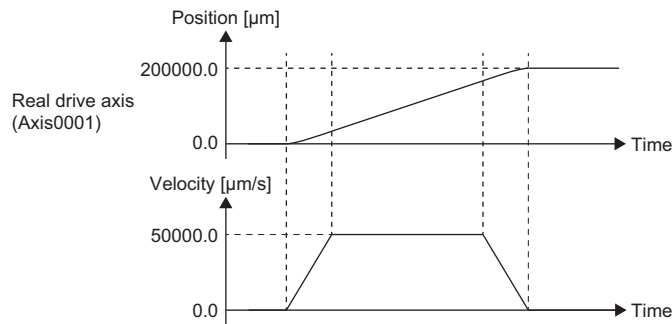

When the single axis positioning command is turned on, the positioning data is stored to each specified label. When all the data is stored, the execution signal of the FB (MC_MoveRelative) is kept on by a self-holding circuit. The start signal is turned off when any of the following conditions are satisfied: the positioning is completed (the AND condition of the Done output of MC_MoveRelative and command in-position); an error occurs; or the execution is aborted.

The interlock conditions are added to prevent execution of the single axis positioning while other programs are running or when a system error occurs.

Start signal

Signal name	Label name
Single axis positioning command	G_bPosCMD

• Relative value positioning, Positioning request, Positioning, Positioning complete

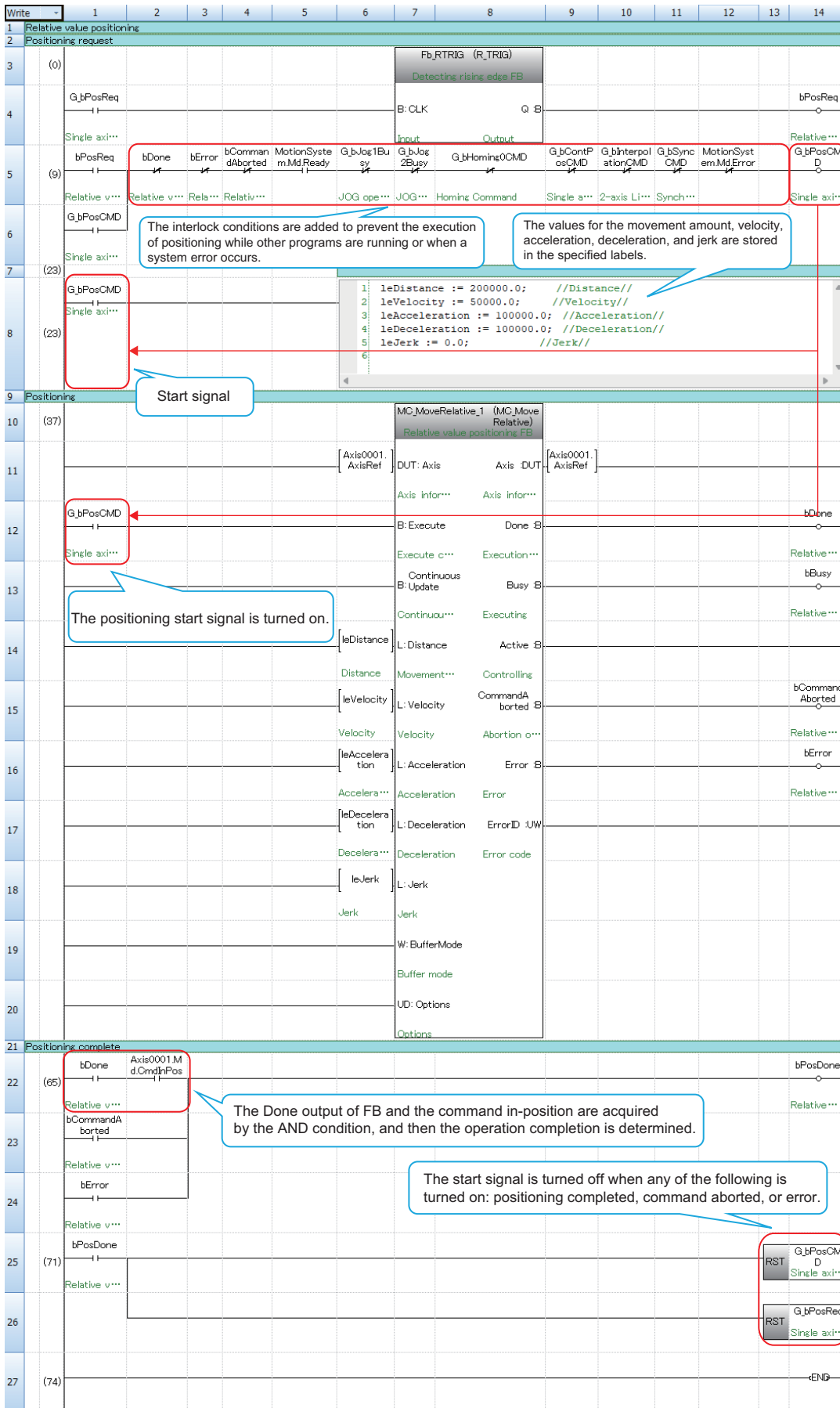

4.9 Single Axis Continuous Positioning (Program Name: ContinuousPosition)

Overview

An axis can continuously execute multiple motion control FBs without stopping by buffering the next operation FB of another instance while executing the first motion control FB.

Select the buffer mode through the BufferMode input of a motion control FB.

Up to two operation FBs can be buffered on one axis.

The example in this section uses an FB (MC_MoveRelative) to perform relative value positioning.

Operation pattern of buffer mode

Buffer mode	Operation
0: mcAborting	<p>The FB being executed is aborted (canceled), and the next FB is immediately executed.</p> <p>Target velocity of FB2 Target velocity of FB1 Accelerates/decelerates to the target velocity of FB2 using acceleration/deceleration of FB2. Target position of FB1 Target position of FB2 Time</p>
1: mcBuffered	<p>The next FB is executed after the FB being executed completes (the axis decelerates to a stop).</p> <p>Velocity Multiple start timing The next FB starts after stopping at the target position. FB being executed Buffering FB Time</p>
2: mcBlendingLow	<p>The lower target velocity between the FB being executed and the next FB is used as the switching velocity.</p>
3: mcBlendingPrevious	<p>The next FB is executed after the target position of the FB being executed is reached. The target velocity is the set velocity of the next FB.</p> <p>Velocity Multiple start Transfer velocity uses the set velocity of current FB. FB being executed Buffering FB Time</p>
4: mcBlendingNext	<p>The next FB is executed after the target position of the FB being executed is reached. When the target position is reached, the velocity is switched to the set velocity of the next FB.</p> <p>Velocity Multiple start Transfer velocity uses the set velocity of buffering FB. FB being executed Buffering FB Time</p>
5: mcBlendingHigh	<p>The higher target velocity between the FB being executed and the next FB is used as the switching velocity.</p>

Local labels

	Label Name	Data Type		Class	English(Display Target)
1	MC_MoveRelative_1	MC_MoveRelative	...	VAR	Relative value positioning FB1
2	MC_MoveRelative_2	MC_MoveRelative	...	VAR	Relative value positioning FB2
3	leDistance1	FLOAT [Double Precision]	...	VAR	Distance1
4	leDistance2	FLOAT [Double Precision]	...	VAR	Distance1
5	leVelocity1	FLOAT [Double Precision]	...	VAR	Velocity1
6	leVelocity2	FLOAT [Double Precision]	...	VAR	Velocity2
7	leAcceleration1	FLOAT [Double Precision]	...	VAR	Acceleration1
8	leDeceleration1	FLOAT [Double Precision]	...	VAR	Deceleration1
9	leAcceleration2	FLOAT [Double Precision]	...	VAR	Acceleration2
10	leDeceleration2	FLOAT [Double Precision]	...	VAR	Deceleration2
11	leJerk	FLOAT [Double Precision]	...	VAR	Jerk
12	bBusy1	Bit	...	VAR	Relative value positioning FB1 Busy output
13	bActive1	Bit	...	VAR	Relative value positioning FB1 Active output
14	bDone2	Bit	...	VAR	Relative value positioning FB2 Done output
15	bBusy2	Bit	...	VAR	Relative value positioning FB2 Busy output
16	TON_1	TON	...	VAR	On-delay timer FB
17	bDwell_in	Bit	...	VAR	Timer input
18	bDwell_out	Bit	...	VAR	Timer output
19	bCommandAborted	Bit	...	VAR	Relative value positioning FB CommandAborted output
20	bError	Bit	...	VAR	Relative value positioning FB Error output
21	bContPosReq	Bit	...	VAR	Relative value positioning start request
22	Fb_RTRIG	R_TRIG	...	VAR	Detecting rising edge FB

No.	Description
1, 2, 16	These labels are automatically added when the user drags and drops the FBs (MC_MoveRelative and TON) onto the program editor.
3 to 15, 17 to 22	These labels are registered manually.

Program example

This program executes relative positioning in the following operation pattern.

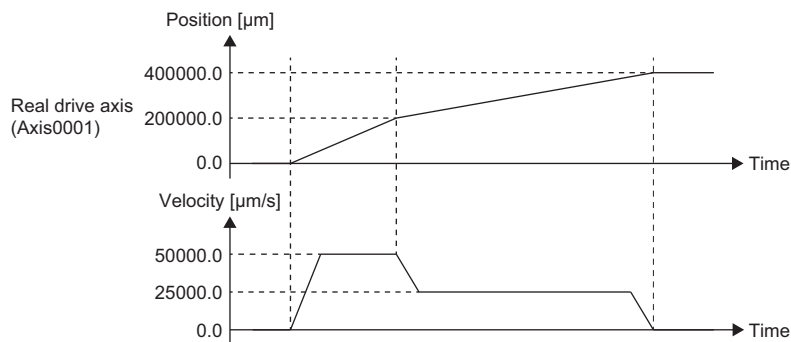

When the single axis continuous positioning command is turned on, the positioning data is stored to each specified label. When all the data is stored, the execution signal of the FB (MC_MoveRelative_1) is kept on by a self-holding circuit. The Active output of the first FB (MC_MoveRelative) is connected to the Execute input of the second FB (MC_MoveRelative), which enables buffering of the second FB while executing the first FB. When the first FB is finished, the second FB is continuously executed. To set the dwell time, the on-delay timer (100 [ms]) is used. The on-delay timer input and the start signal are reset when any of the following conditions are satisfied: the dwell time is passed; an error occurs; or the execution is aborted. The interlock conditions are added to prevent execution of the single axis continuous positioning while other programs are running or when a system error occurs.

Start signal

Signal name	Label name
Single axis continuous positioning command	G_bContPosCMD

- Relative value positioning, Positioning request

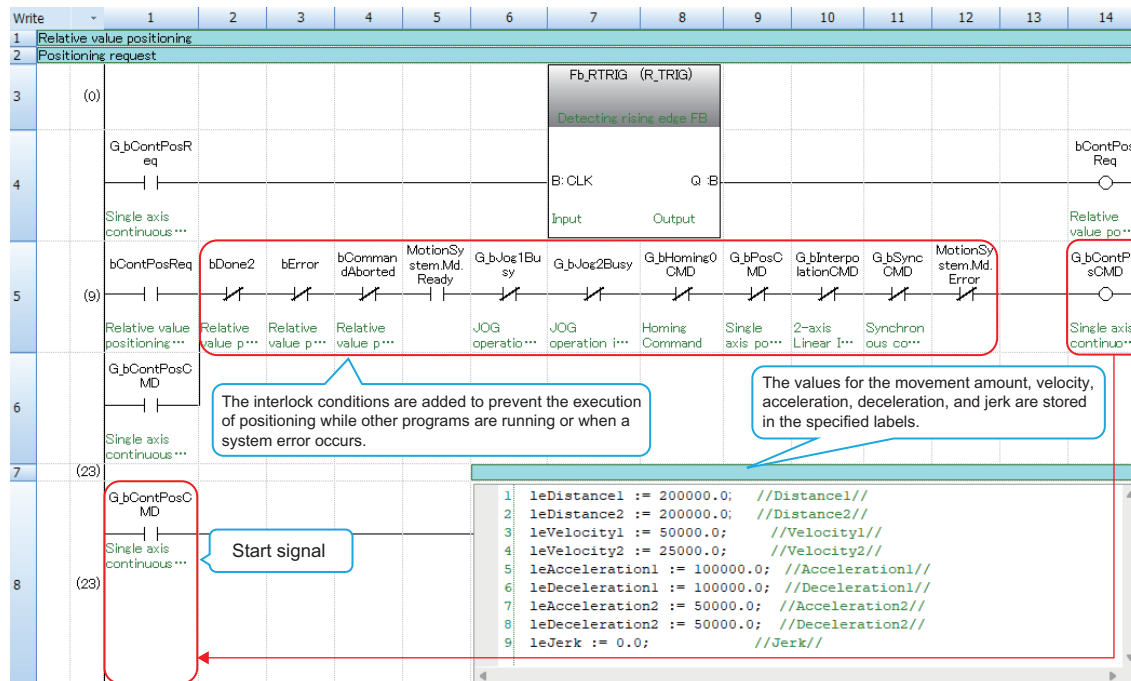

• Positioning + Buffer mode + Dwell, Relative value positioning 1

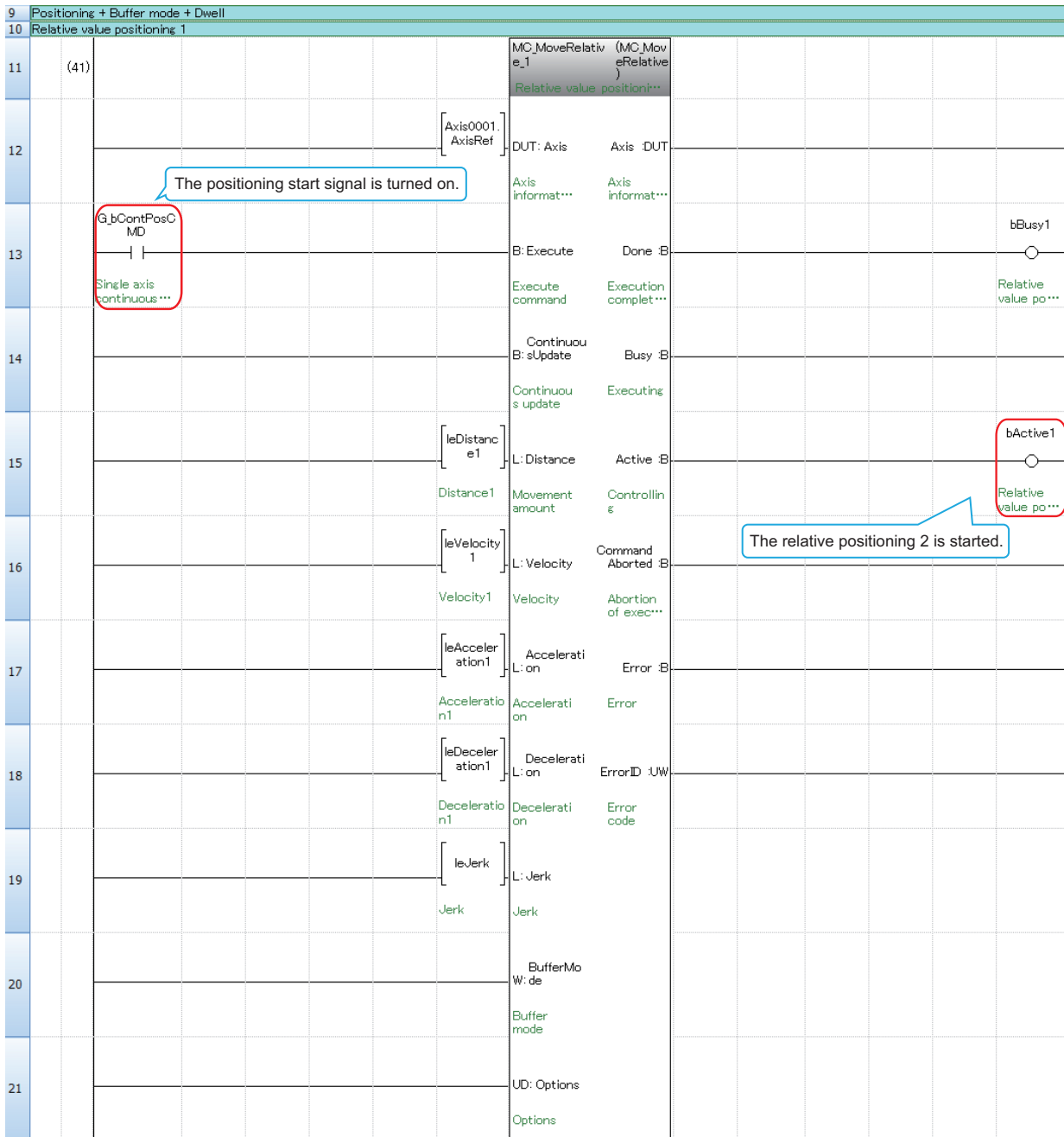

• Relative value positioning 2



• FB CommandAborted output, FB Error output

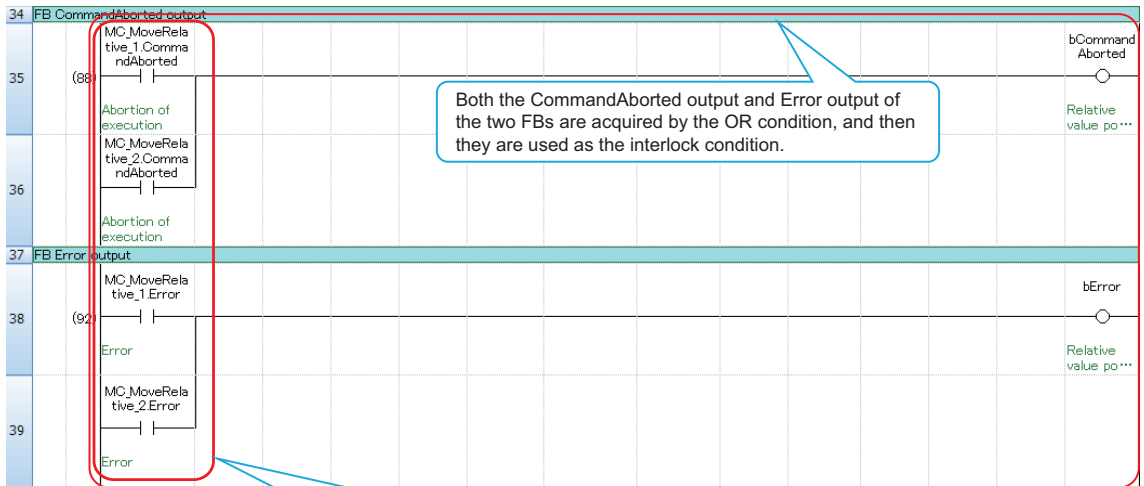

The FB output variable name "(FB instance name).(output variable name)" in the program can be entered directly.

MC_MoveRelative_1.Error

Output variable name

FB instance name

- Sets timer input with relative value positioning 2 complete signal, Dwell, Positioning complete signal, Resets timer input when positioning is completed

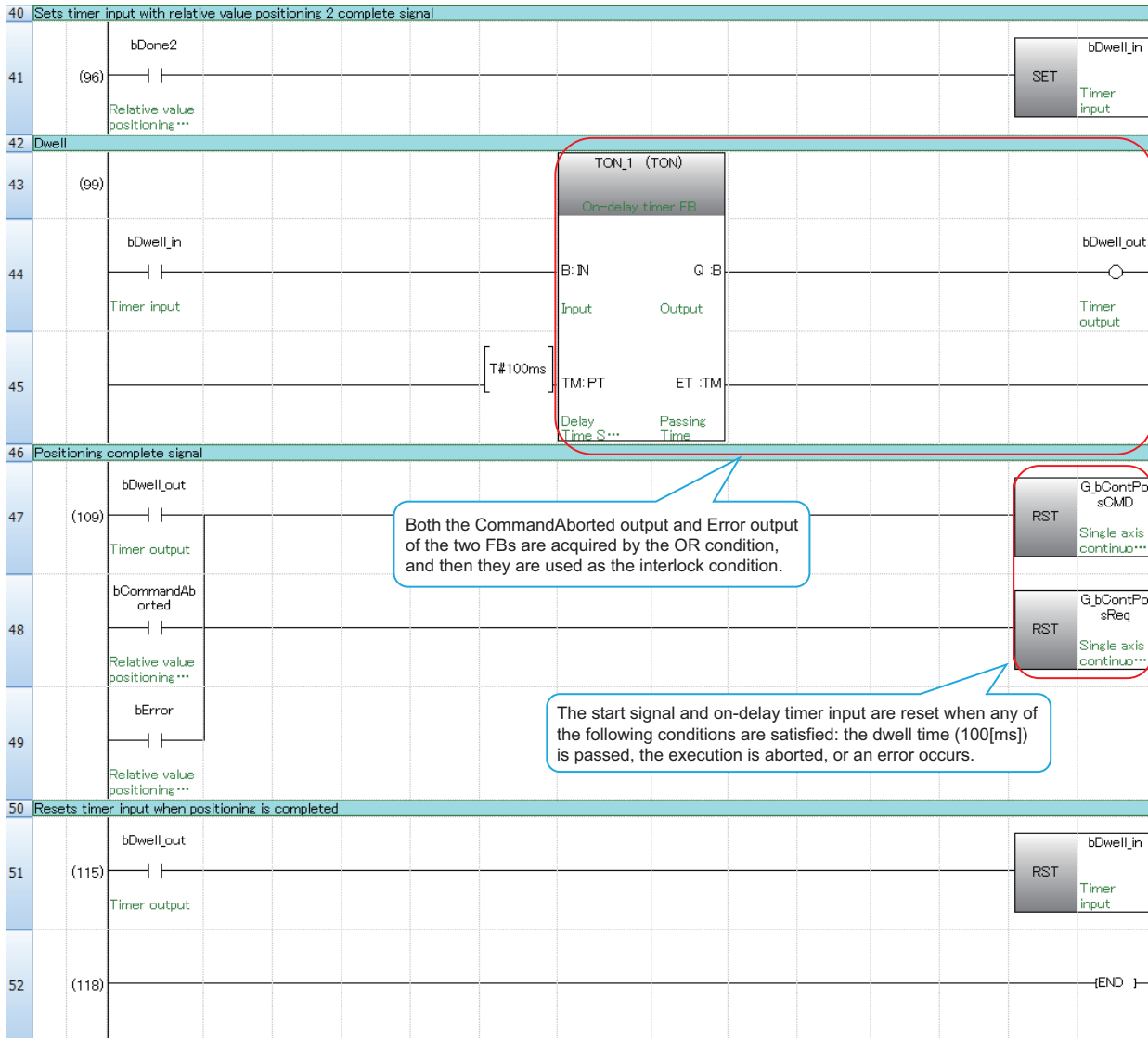

4.10 Interpolation Control (Program Name: LinearInterpolation)

Procedure for interpolation control

The following shows the procedure flow for executing interpolation control of two or more axes.

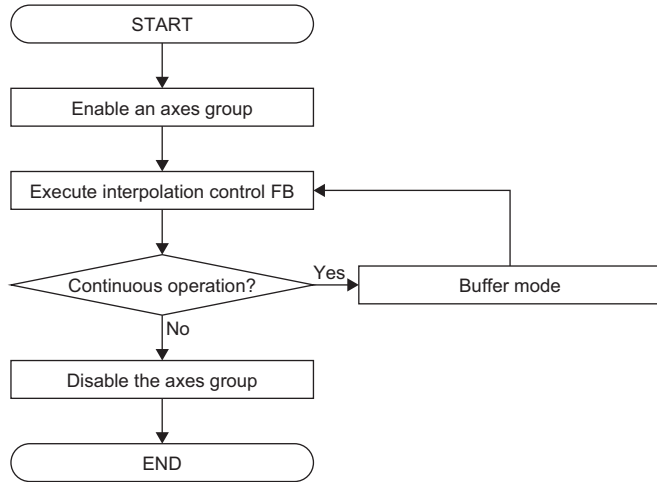

Enabling/disabling an axes group

For axes group setting, refer to the following.

☞ Page 50 Axes group settings

To execute interpolation control, change the axes group status to "4: Standby (GroupStandby)" and enable the axes group.

FBs used		
Type	FB	Description
Administrative	MC_GroupEnable	Changes the specified axes group status from "0: Axes group disabled (GroupDisabled)" to "4: Standby (GroupStandby)".
	MC_GroupDisable	Changes the specified axes group status to "0: Axes group disabled (GroupDisabled)".

Interpolation control

For FBs that perform interpolation control, FBs for linear and circular interpolation control are available. Execute the following FBs after the axes group is enabled.

FBs used		
Type	FB	Description
Motion	MCv_MoveLinearInterpolateAbsolute	Specifies the target position of the absolute position of the set axes group, and executes positioning by linear interpolation control.
	MCv_MoveLinearInterpolateRelative	Specifies the movement amount of the relative position of the set axes group, and executes positioning by linear interpolation control.
	MCv_MoveCircularInterpolateAbsolute	Executes positioning with 2-axis circular interpolation using the structuring axes of the set axes group by setting the end point and sub point of the absolute position.
	MCv_MoveCircularInterpolateRelative	Executes positioning with 2-axis circular interpolation using the structuring axes of the set axes group by setting the relative position from the current position at start to the end point and sub point.

Program example for linear interpolation

Operation pattern

The machine goes back and forth between the origin point (0.0, 0.0) [μm] and point P1 (100000.0, 200000.0) [μm].

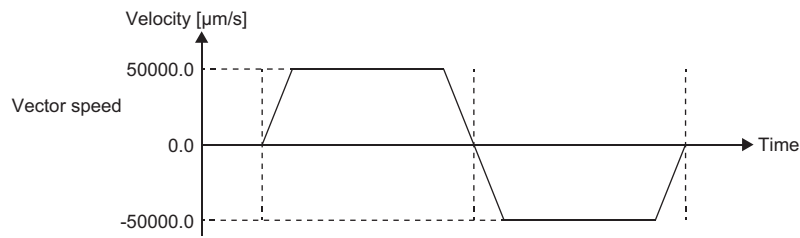
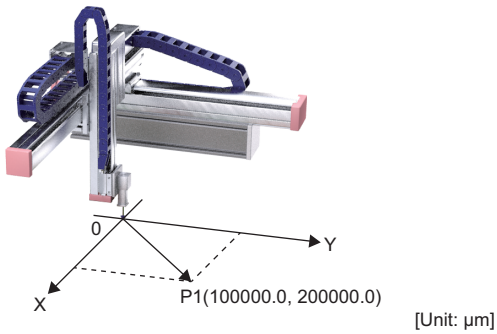

Linear interpolation axis and movement amount settings

■LinearAxes input of MCv_MoveLinearInterpolateRelative

Set the data type of the label to connect to the LinearAxes input as INT type (Word [signed]) with 16 elements in the array. In the sample program, the labels for wAxes[0] to wAxes[15] are used.

For the AxesGroup input, store the configuration axis No. of the axes to be used for the linear interpolation in order, starting from wAxes[0]. Select these axes from configuration axes [1] to [16] set in the axes group parameter.

■Distance input of MCv_MoveLinearInterpolateRelative

Set the data type of the label to connect to the Distance input as LREAL type (double-precision real number) with 16 elements in the array.

In the sample program, the labels for lePosition[0] to lePosition[15] are used.

For AxesGroup of lePosition[0] to lePosition[15], store the movement amount of configuration axes [1] to [16] set in the axes group parameter.



Regardless of the number of the interpolation control axes, the number of elements must be 16 for the arrays used in both the LinearAxes input data type (INT type) and the Distance input data type (LREAL type).

■Setting examples

When setting the following axes group

Item	Data name
Configuration Axis[1]	Axis0001
Configuration Axis[2]	Axis0002

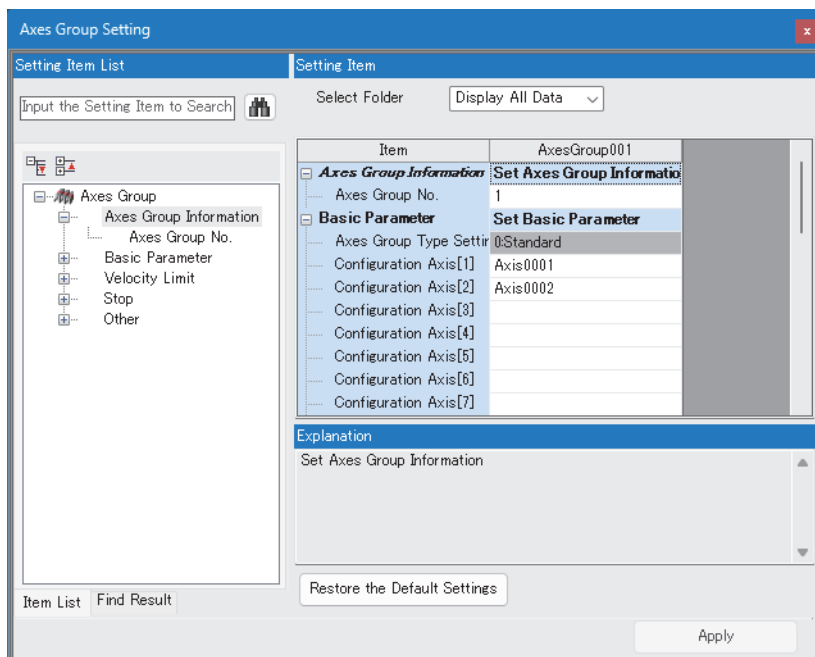

Local label

	Label Name	Data Type		Class	English(Display Target)
1	MCv_MoveLinearInterpolateRelative_1	MCv_MoveLinearInterpolateRelative	...	VAR	Relative value linear interpolation control FB1
2	MCv_MoveLinearInterpolateRelative_2	MCv_MoveLinearInterpolateRelative	...	VAR	Relative value linear interpolation control FB2
3	MC_GroupEnable_1	MC_GroupEnable	...	VAR	Axes group enable FB
4	MC_GroupDisable_1	MC_GroupDisable	...	VAR	Axes group disable FB
5	wAxes	Word [Signed](0.15)	...	VAR	Interpolation axis
6	lePosition1	FLOAT [Double Precision](0.15)	...	VAR	Position data 1
7	lePosition2	FLOAT [Double Precision](0.15)	...	VAR	Position data 2
8	leVelocity	FLOAT [Double Precision]	...	VAR	Velocity
9	leAcceleration	FLOAT [Double Precision]	...	VAR	Acceleration
10	leDeceleration	FLOAT [Double Precision]	...	VAR	Deceleration
11	leJerk	FLOAT [Double Precision]	...	VAR	Jerk
12	bGroupEnableDone	Bit	...	VAR	Axes group enable done
13	bGroupDisableDone	Bit	...	VAR	Axes group disable done
14	bBusy1	Bit	...	VAR	Relative value linear interpolation control FB1 Busy output
15	bActive1	Bit	...	VAR	Relative value linear interpolation control FB1 Active output
16	bDone2	Bit	...	VAR	Relative value linear interpolation control FB2 Done output
17	bBusy2	Bit	...	VAR	Relative value linear interpolation control FB2 Busy output
18	T_ON_1	T_ON	...	VAR	On-delay timer FB
19	bDwell_out	Bit	...	VAR	Timer output
20	bDwell_in	Bit	...	VAR	Timer input
21	bCommandAborted	Bit	...	VAR	Relative value linear interpolation control FB CommandAborted output
22	bError	Bit	...	VAR	Relative value linear interpolation control FB Error output
23	bInterpolationReq	Bit	...	VAR	Relative value linear interpolation control start request
24	Fb_RT_RIG	R_T_RIG	...	VAR	Detecting rising edge FB
25	bExecute	Bit	...	VAR	Execute

No.	Description
1 to 4, 18	These labels are automatically added when the user drags and drops the FBs (MC_GroupEnable, MCv_MoveLinearInterpolateRelative, MC_GroupDisable, and TON) onto the program editor.
5 to 17, 19 to 25	These labels are registered manually.

Program example

When the two-axis linear interpolation control start is turned on, the positioning data is stored to each specified label. When all the data is stored, the execution signal of the FB (MC_GroupEnable_1) is kept on through a self-holding circuit. After the axes group is enabled by the FB (MC_GroupEnable), the two FBs for relative value linear interpolation control (MCv_MoveLinearInterpolateRelative) are started in buffer mode.

The axes group is disabled when any of the following conditions are satisfied: the dwell time is passed after the positioning is completed; an error occurs; or the execution is aborted. The on-delay timer and the start signal are reset when the axes group is disabled.

The interlock conditions are added to prevent execution of the two-axis interpolation control while other programs are running or when a system error occurs.

Start signal

Signal name	Label name
Two-axis linear interpolation control start	G_bInterpolationCMD

Point

When the values for the Velocity, Acceleration, and Deceleration inputs are omitted for the buffering FB, those of the previous FB are applied.

- 2-axis linear interpolation control, Positioning request

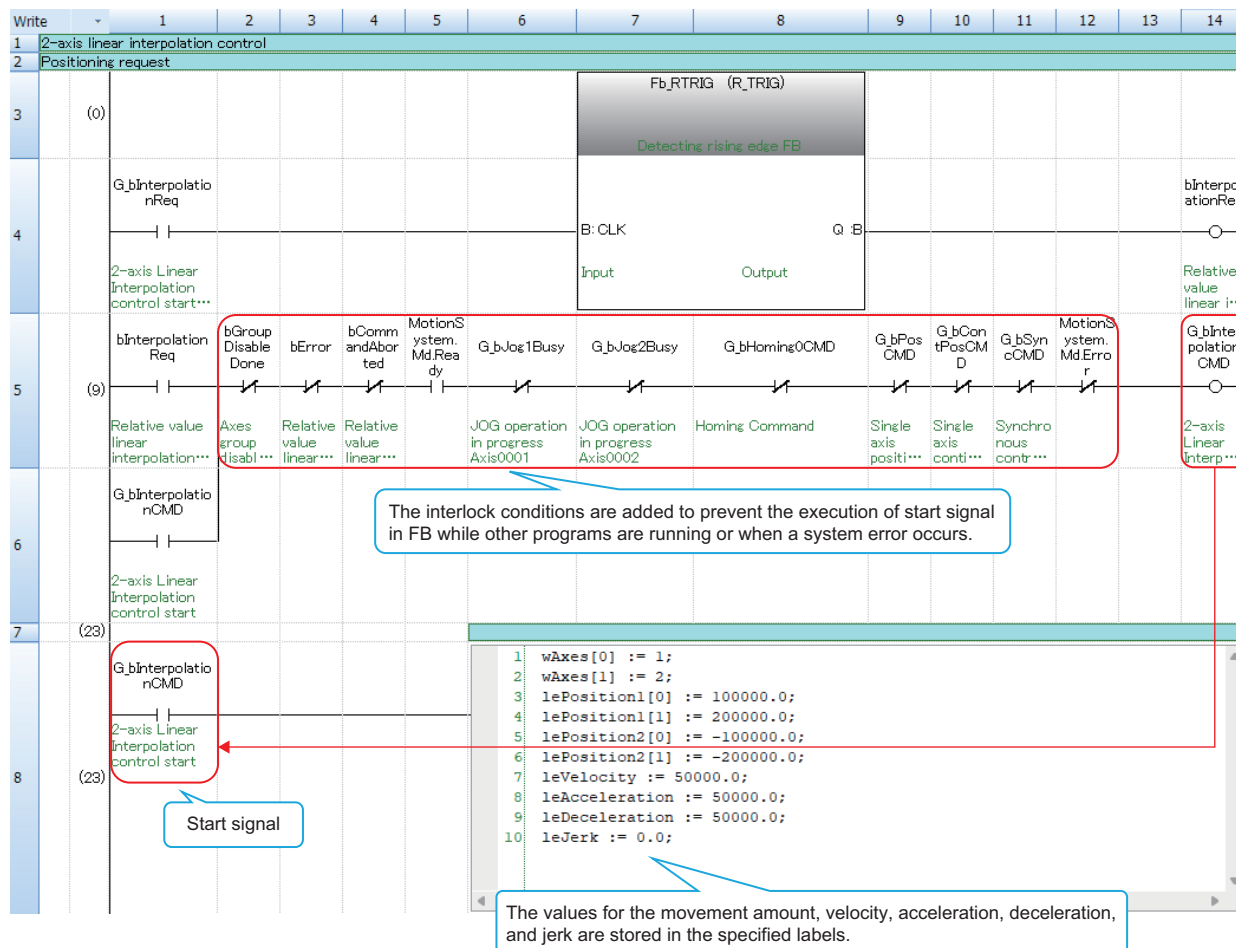

• Linear interpolation control + Buffer mode, Axes group enable

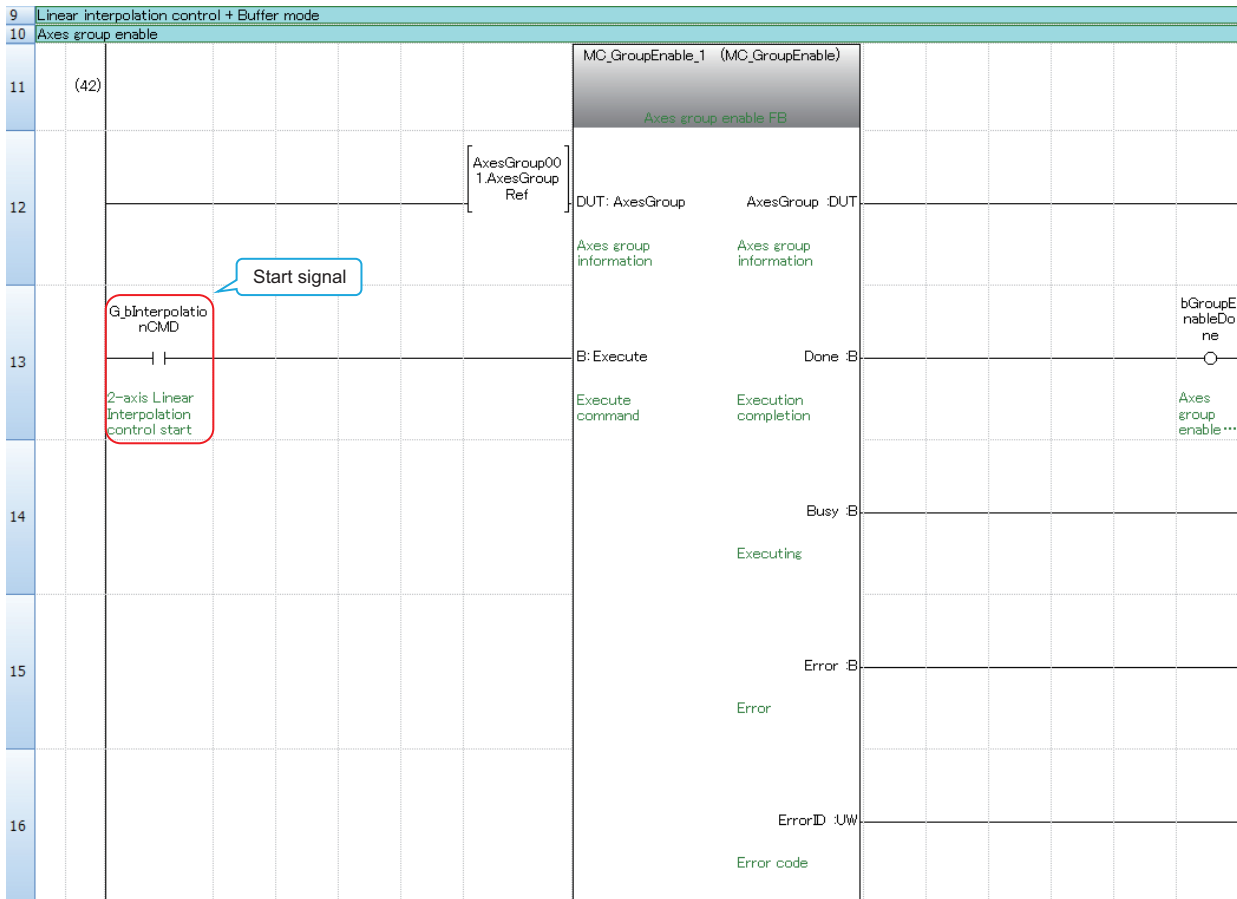

• Linear interpolation control 1

The Done output of the enabled FB is connected to the Execute input of the first relative value linear interpolation control FB and the axis group is enabled.

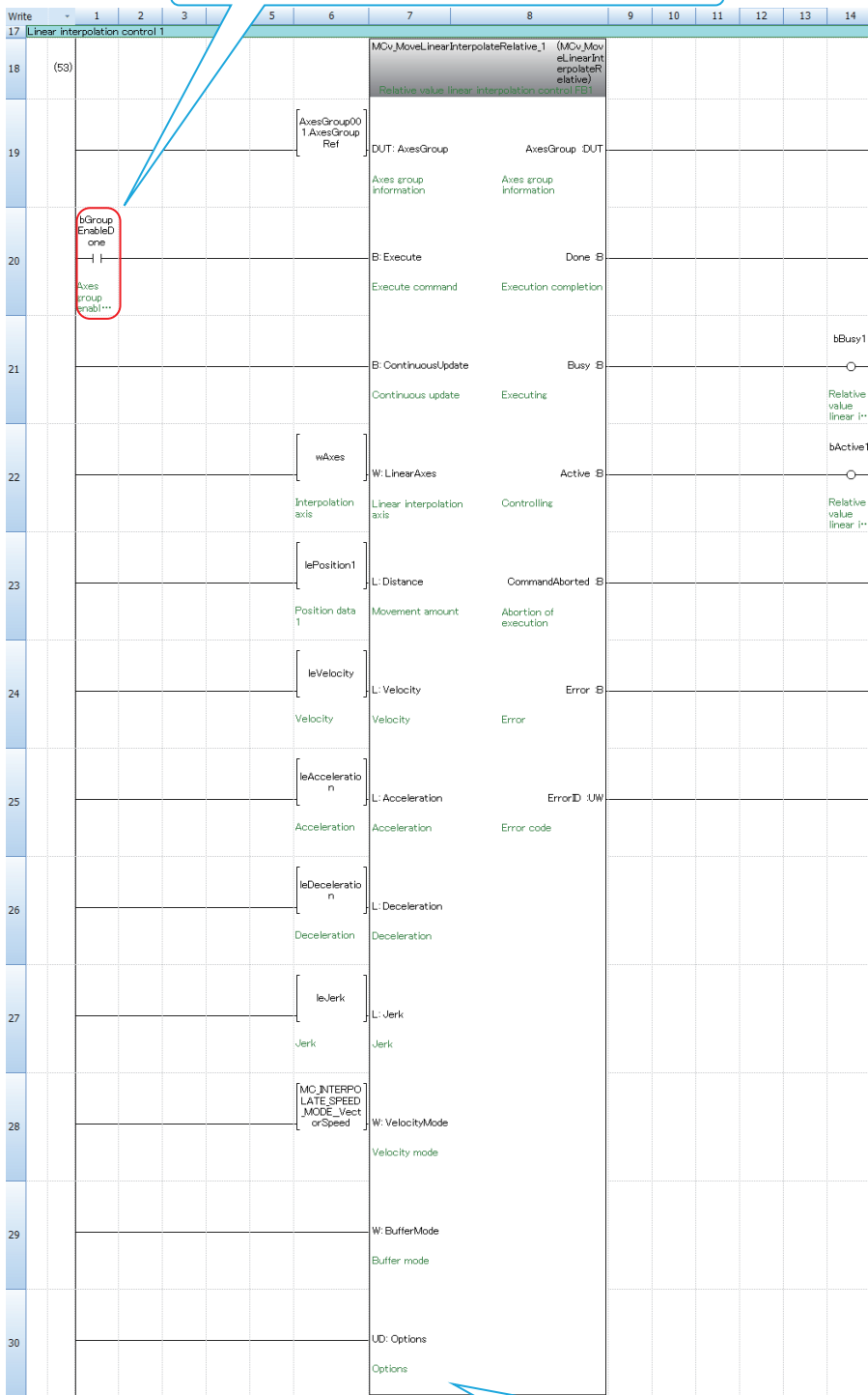

After the relative value linear interpolation control FB (MCv_MoveLinearInterpolateRelative) axis group is enabled, the two relative value linear interpolation control FBs are started in buffer mode.

• Linear interpolation control 2

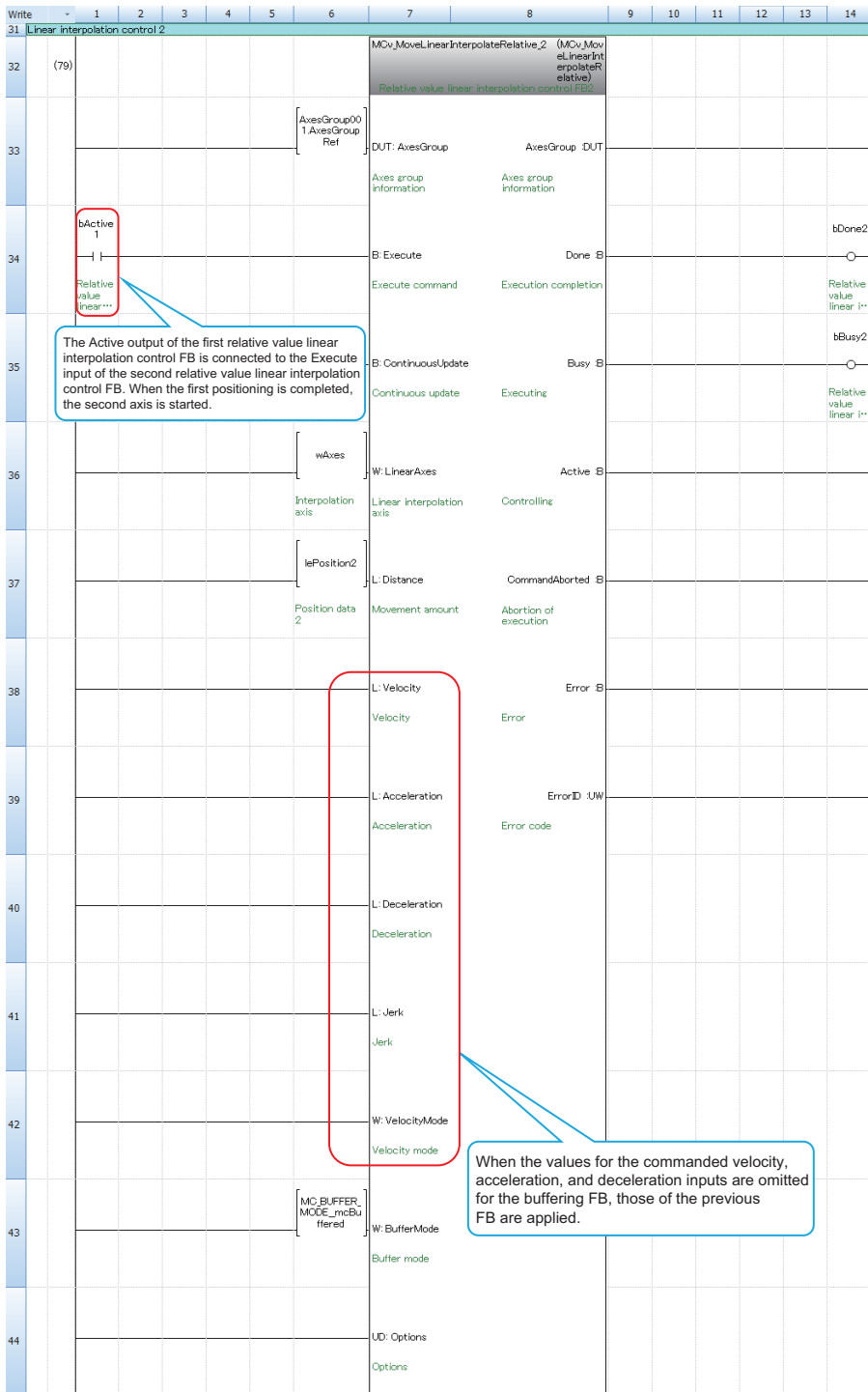

The Active output of the first relative value linear interpolation control FB is connected to the Execute input of the second relative value linear interpolation control FB. When the first positioning is completed, the second axis is started.

When the values for the commanded velocity, acceleration, and deceleration inputs are omitted for the buffering FB, those of the previous FB are applied.

- FB CommandAborted output, FB error output, Sets timer input with linear interpolation control 2 complete signal or FB CommandAborted output, Dwell

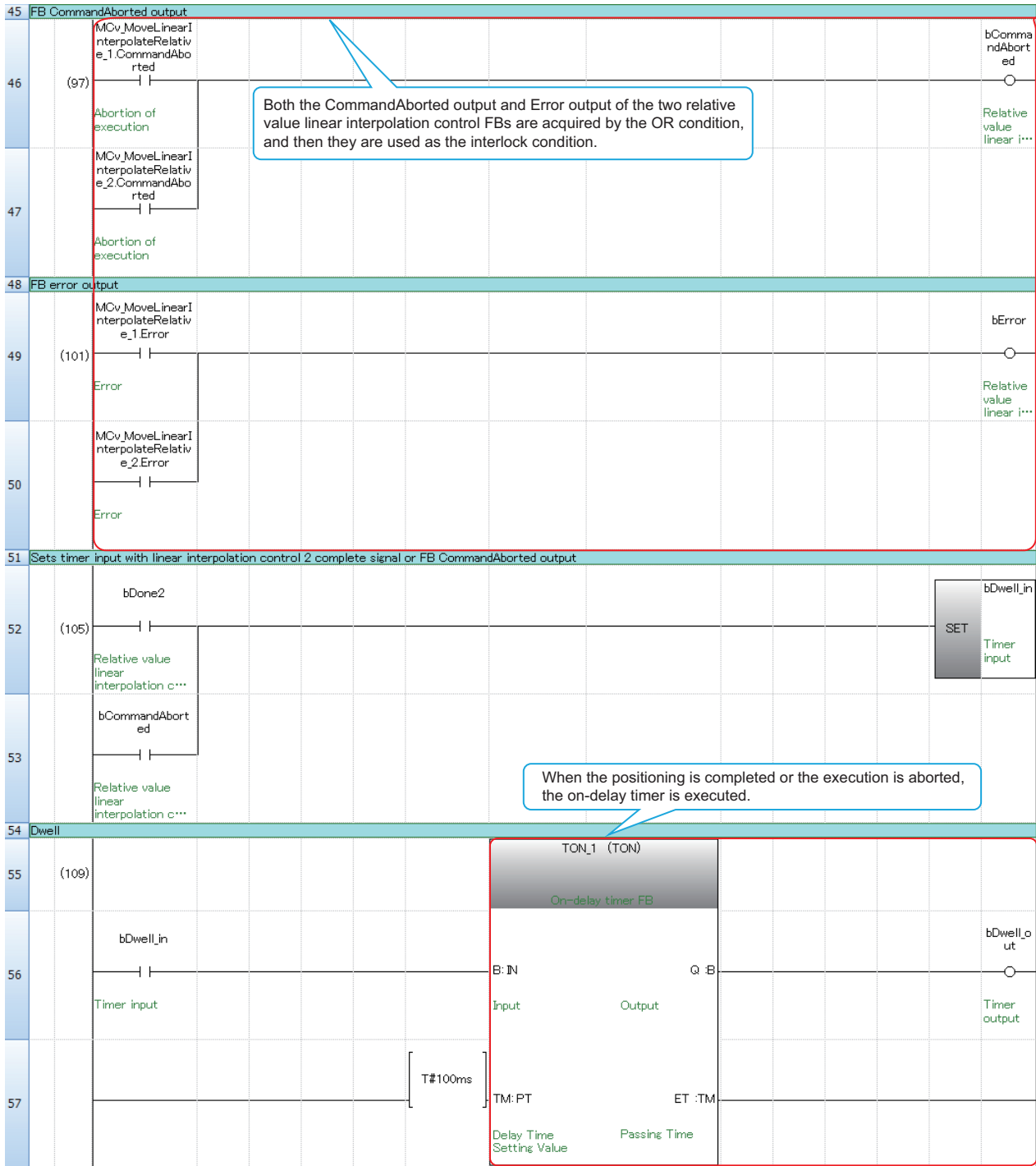

• Axes group disable

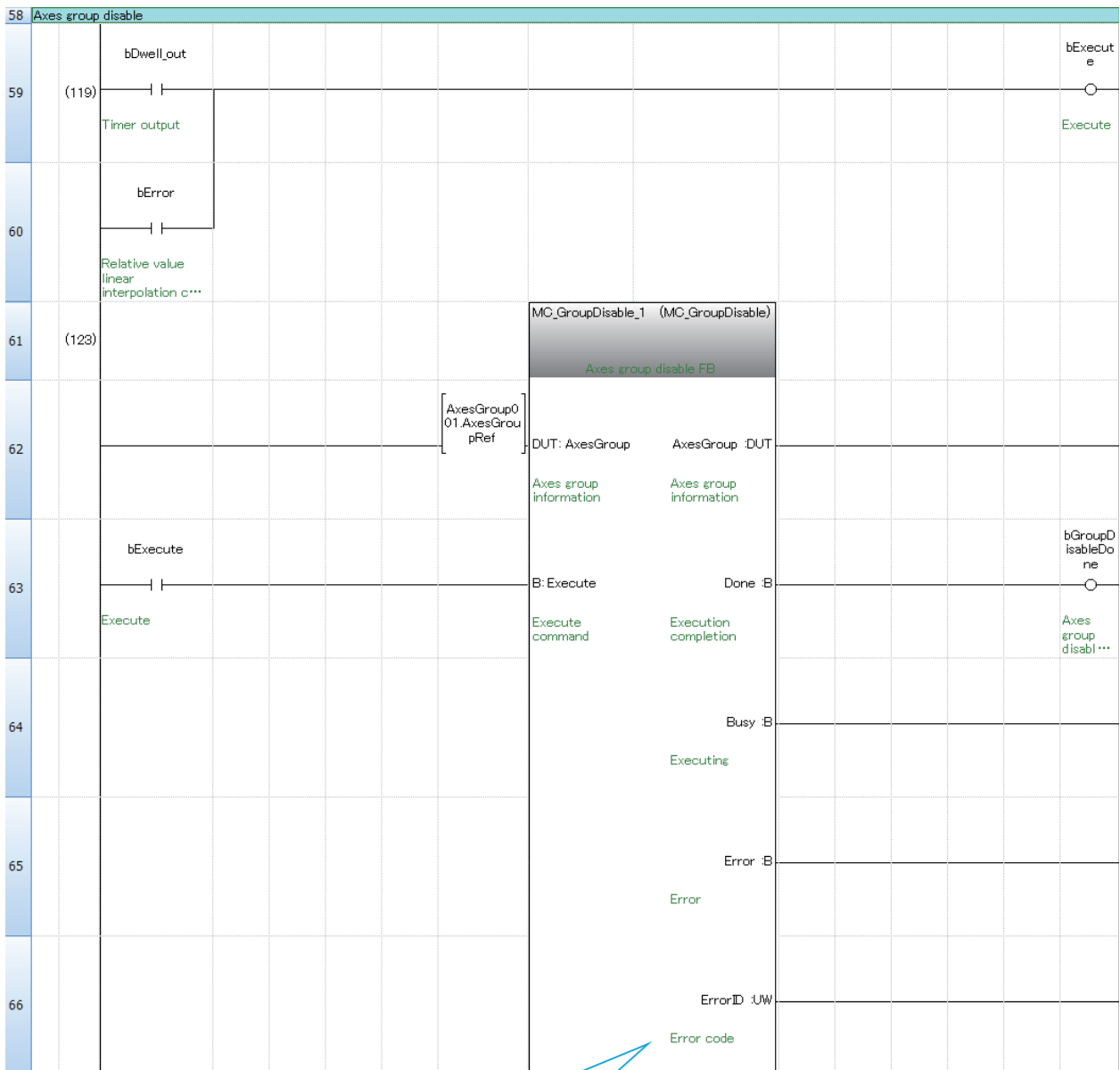

When the axis group disable FB (MC_GroupDisable) dwell time is passed or an error occurs in linear interpolation control, the group is disabled.

- Positioning complete signal, Resets timer input when positioning is completed

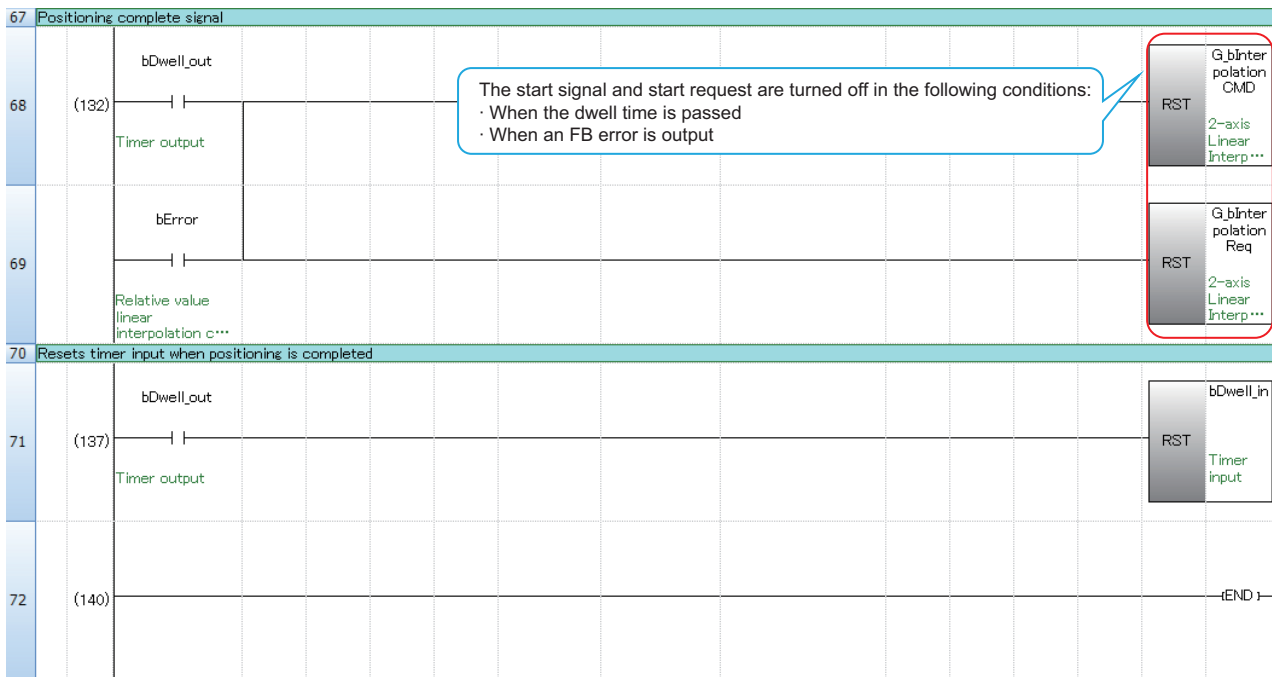

4.11 Synchronous Control (Program Name: Synchronous)

Procedures for executing synchronous control

The following shows the procedure flow for executing synchronous control.

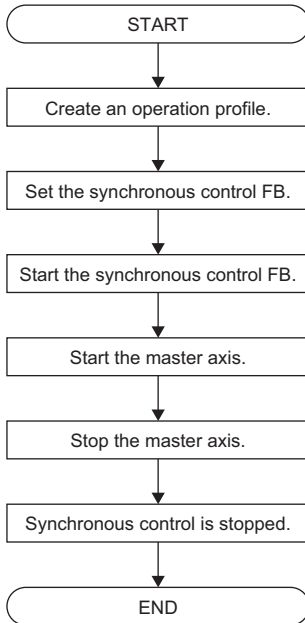

Operation profile

Waveform data used for control are collectively called operation profiles.
This section describes how to create cam data.

Create a new operation profile

Operating procedure

1. In the Navigation window, right-click "Operation Profile Data" and select "Add New Data". The "New Data" window is displayed.

2. Set the data name, type, interpolation method specification, etc., and click the [OK] button.
The example in this guide uses the initial values.
The following are the items set in the expand setting.

Setting item	Description
Repetitive Operation	<ul style="list-style-type: none"> • Disable: Once the control is performed until the end point of the operation profile, the control terminates. • Enable: The execution of operation profile data is continuously repeated.
Output Absolute Coordinate	<ul style="list-style-type: none"> • Disable (Relative Coordinate): When the operation profile (cam data) is started, an output value is calculated based on the current value. When executing a feed cam operation, select this setting. • Enable (Absolute Coordinate): The output value at the time the operation profile (cam data) is started is calculated to be always the start point for one cycle of the operation profile data. When the start point and the end point of the operation profile data are different, the command is output in one operation cycle to return to the first output value at the next one cycle start.

3. The operation profile is added to the navigation window.

Creating cam data

Set the operation profile waveform.

Section No.	Start Point[pulse]	End Point[pulse]	Stroke[pulse]	Cam Curve Type	Input	End Point Velocity[pulse/s]	End Point Acceleration[pulse/s ²]
1	0	50000	100000	Single Hypot.		-0	-72035684
2	50000	100000	200000	Single Hypot.		0	-7895684
3	100000	150000	50000	Single Hypot.		0	11843525
4	150000	0	0	Single Hypot.		0	3947842

The following are the items set to the operation profile.

Item	Setting value	Description
Resolution	256	Set the resolution of the cam data.
Length per Cycle Setting	200000 (Unit: pulse)	Set the length per cycle and its unit. (Set the movement amount of the master axis for one cam cycle.)
Stroke Amount Setting	200000 (Unit: pulse)	Set the stroke amount and its unit. (Set the movement amount of the slave axis for one cam cycle.)
Cam Time Setting per Cycle	1.000	Set the time for one cam cycle. This setting is used when velocity, acceleration, and jerk are calculated.
Stroke Setting	Setting values for the stroke setting	Set the stroke.

Section No.	Start point	End point	Stroke	Cam curve type
1	0	50000	100000	Single hypotenuse
2	50000	100000	200000	Single hypotenuse
3	100000	150000	50000	Single hypotenuse
4	150000	0	0	Single hypotenuse

Point

When executing linear cam operation (the same operation as the master axis, or an operation that changes the master axis velocity based on a specified velocity ratio), create an operation profile for the linear cam, or use MC_GearIn.

The operation profile data for the linear cam is not provided in the system.

Single axis synchronous control FBs

The single axis synchronous control FBs operate as software-based mechanical modules such as gears, speed change gears, and cams. These FBs transmit the position information (command) of Slave that is synchronized with Master.

FBs used

Type	FB	Description
Motion	MC_CamIn	Executes cam operation.
	MC_GearIn	Executes gear operation based on the specified velocity ratio between the master axis and the slave axis.
	MC_CombineAxes	Combines the motion of two axes by a selectable combination method and outputs the result to the third axis.
	MCv_BacklashCompensationFilter	Executes the specific filter processing to the input of Master and outputs the result to Slave.
	MCv_SmoothingFilter	
	MCv_DirectionFilter	
	MCv_SpeedLimitFilter	
	MC_Stop	Decelerates the specified axis to a stop. Used to stop the synchronous control.
Administrative	MCv_ChangeCycle	Changes the cam current value per cycle to the specified value during MC_CamIn control. It is used to compensate the cam current value per cycle into an arbitrary value.

Axes configuration

This section describes the following cam system.

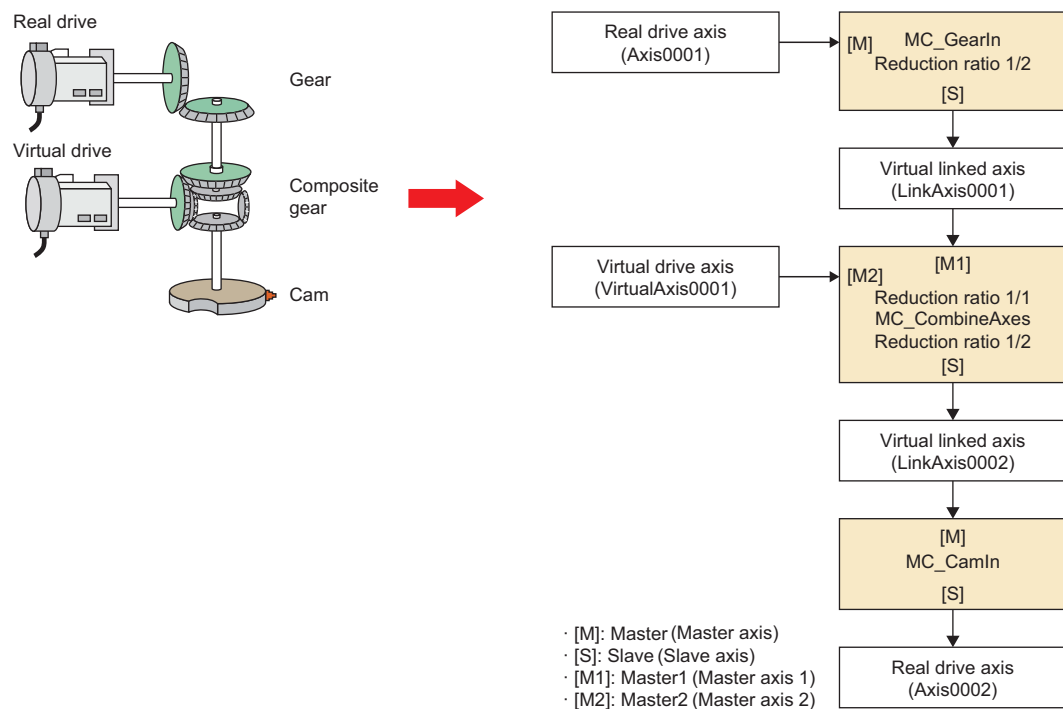

Program example for synchronous control

Operation pattern

The X-axis (Axis0001) moves from the origin point for 400000.0 [μm] while the Y-axis (Axis0002) is operated according to the cam pattern created in Operation profile (Page 99 Operation profile). When the X-axis reaches the target position (400000.0 [μm]), the virtual drive axis starts operation and the Y-axis repeats the cam operation. At this time, the X-axis is stopped and only the Y-axis is operated.

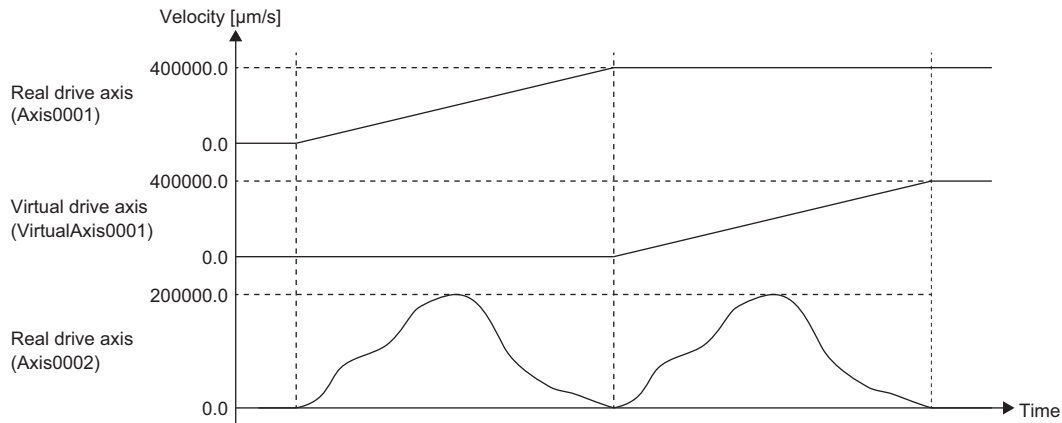

Virtual drive axis and virtual linked axis

This program uses the virtual drive axis (VirtualAxis0001) and the virtual linked axes (LinkAxis0001, LinkAxis0002) in addition to the real drive axes (Axis0001, Axis0002).

Local labels

No.	Label Name	Data Type	Class	English(Display Target)
1	MC_GearIn_1	MC_GearIn	VAR	Gear operation FB
2	MC_CombineAxes_1	MC_CombineAxes	VAR	FB combining the motion of two master axes
3	MC_CamIn_1	MC_CamIn	VAR	Cam operation FB
4	bGearInBusy	Bit	VAR	Gear operation FB Busy output
5	bCombineAxesBusy	Bit	VAR	FB combining the motion of two master axes Busy output
6	bCamInBusy	Bit	VAR	Cam operation FB Busy output
7	MC_MoveRelative_1	MC_MoveRelative	VAR	Synchronous control FB1
8	MC_MoveRelative_2	MC_MoveRelative	VAR	Synchronous control FB2
9	MC_Stop_1	MC_Stop	VAR	Axis Stop FB1
10	MC_Stop_2	MC_Stop	VAR	Axis Stop FB2
11	MC_Stop_3	MC_Stop	VAR	Axis Stop FB3
12	leAcceleration	FLOAT [Double Precision]	VAR	Acceleration
13	leDeceleration	FLOAT [Double Precision]	VAR	Deceleration
14	leJerk	FLOAT [Double Precision]	VAR	Jerk
15	lePosition1	FLOAT [Double Precision]	VAR	Distance
16	leVelocity	FLOAT [Double Precision]	VAR	Velocity
17	bInSync	Bit	VAR	Cam operation FB in Sync output
18	bDone1	Bit	VAR	Synchronous control FB1 Done output
19	bBusy1	Bit	VAR	Synchronous control FB1 Busy output
20	bDone2	Bit	VAR	Synchronous control FB2 Done output
21	bBusy2	Bit	VAR	Synchronous control FB2 Busy output
22	bStopReq1	Bit	VAR	Axis Stop request 1
23	bStopDone1	Bit	VAR	Axis Stop complete 1
24	bStopDone2	Bit	VAR	Axis Stop complete 2
25	bStopDone3	Bit	VAR	Axis Stop complete 3
26	bSyncMoveCMD	Bit	VAR	Synchronous control start
27	bCommandAborted	Bit	VAR	Synchronous control FB CommandAborted output
28	bError	Bit	VAR	Synchronous control FB Error output
29	bSyncReq	Bit	VAR	Synchronous control start request
30	Fb_RTRIG	R_TRIG	VAR	Detecting rising edge FB
31	bExecute	Bit	VAR	Synchronous control FB2 Execute

No.	Description
1 to 3, 7 to 11	These labels are automatically added when the user drags and drops the FBs (MC_GearIn, MC_CombineAxes, MC_CamIn, MC_MoveRelative, and MC_Stop) onto the program editor.
4 to 6, 12 to 31	These labels are registered manually.

Program example

When the synchronous control start is turned on, the positioning data is stored to each specified label.

When all the data is stored, the execution signal of the FB (MC_GearIn, MC_CombineAxes, and MC_CamIn) is kept on by a self-holding circuit.

When the axis status of Axis0002 is turned to "7: During synchronous operation (SynchronizedMotion)", Axis0001 (Master axis) starts positioning. At this time, Axis0002 is operated according to the specified operation profile. When positioning of Axis0001 is completed, the virtual drive axis (VirtualAxis0001) starts positioning.

At this time, Axis0001 is stopped, but Axis0002 is operated according to the specified operation profile.

The synchronous control is stopped by executing the FB (MC_Stop) on the real drive axis (Axis0002) and the virtual link axes (LinkAxis0001 and LinkAxis0002) when any of the following conditions are satisfied: the positioning of the virtual drive axis (VirtualAxis0001) is completed; an error occurs; or the execution is aborted. The start signal is reset when the real drive axis (Axis0002) status is out of synchronization.

The interlock conditions are added to prevent execution of the synchronous control while other programs are running or when a system error occurs.

■Start signal

Signal name	Label name
Synchronous control start	G_bSyncCMD

• Synchronous control, Positioning request, Gear operation

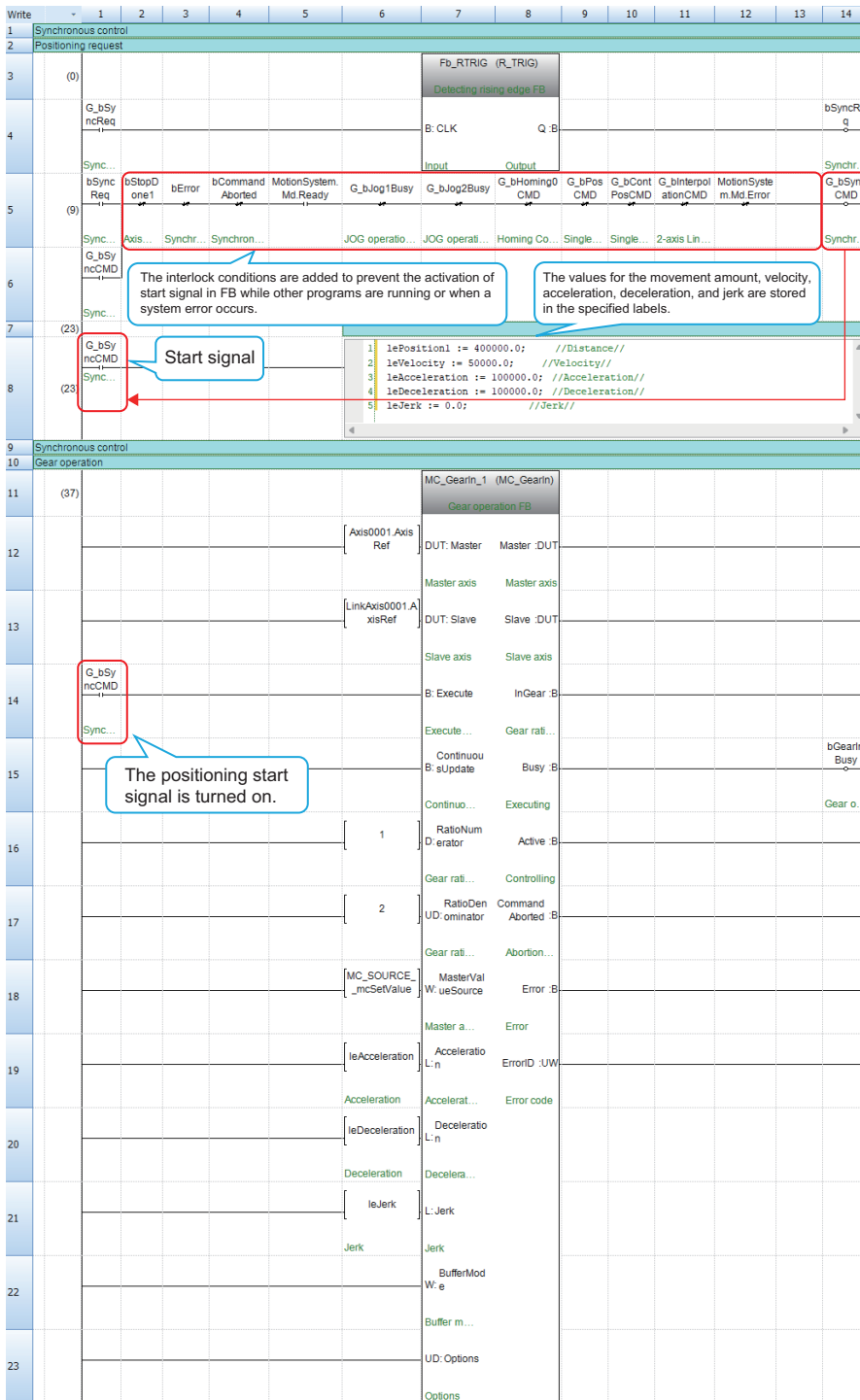

• Combining the motion of two master axes

Line	Symbol	Object	Object Name	Object Type	Object Value
24			MC_CombineAxes_1 (MC_CombineAxes)	Function Block	
25	(62)		FB combining the motion of two ma	Function Block	
26		[LinkAxis0001.AxisRef]	DUT: Master1	Master1 :DUT	
			Master axis 1	Master axis 1	
27		[VirtualAxis0001.AxisRef]	DUT: Master2	Master2 :DUT	
			Master axis 2	Master axis 2	
28		[LinkAxis0002.AxisRef]	DUT: Slave	Slave :DUT	
			Slave axis	Slave axis	
29	G_bSyncCMD		B: Execute	InSync :B	
	Sync...		Execute com...	In synchroniz...	
30			ContinuousUpdate	Busy :B	bCombineAxesBusy
			Continuous u...	Executing	FB comb...
31		[MC_COMBINE_MODE_mcAddAxes]	W: CombineMode	Active :B	
			Addition/subtr...	Controlling	
32		[1]	GearRatioNumeratorM1	CommandAborted :B	
			Master axis 1...	Abortion of ex...	
33		[1]	GearRatioDenominatorM1	Error :B	
			Master axis 1...	Error	
34		[1]	GearRatioNumeratorM2	ErrorID :UW	
			Master axis 2...	Error code	
35		[2]	GearRatioDenominatorM2		
			Master axis 2...		
36		[MC_SOURCE_masterValueM1]	W: sourceM1	MasterValueS	
			Master axis 1...		
37		[MC_SOURCE_masterValueM2]	W: sourceM2	MasterValueS	
			Master axis 2...		
38			W: BufferMode	Buffer mode	
39			UD: Options	Options	

• Cam operation



- Input axis start, Axis0001/Relative value positioning real drive axis Axis0001



• Relative value positioning virtual drive axis VirtualAxis0001

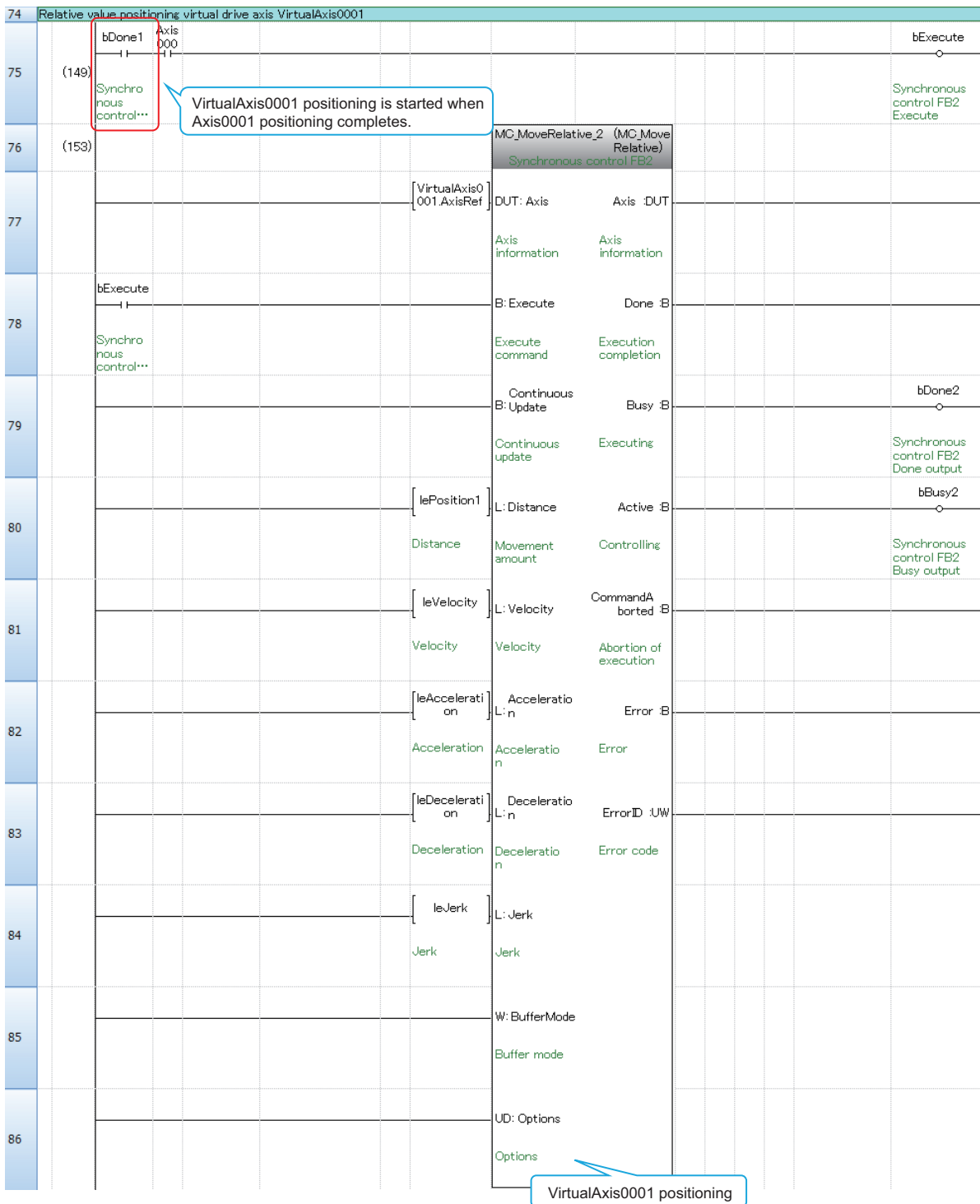

- FB CommandAborted output, FB error output, Turns axis stop signal ON

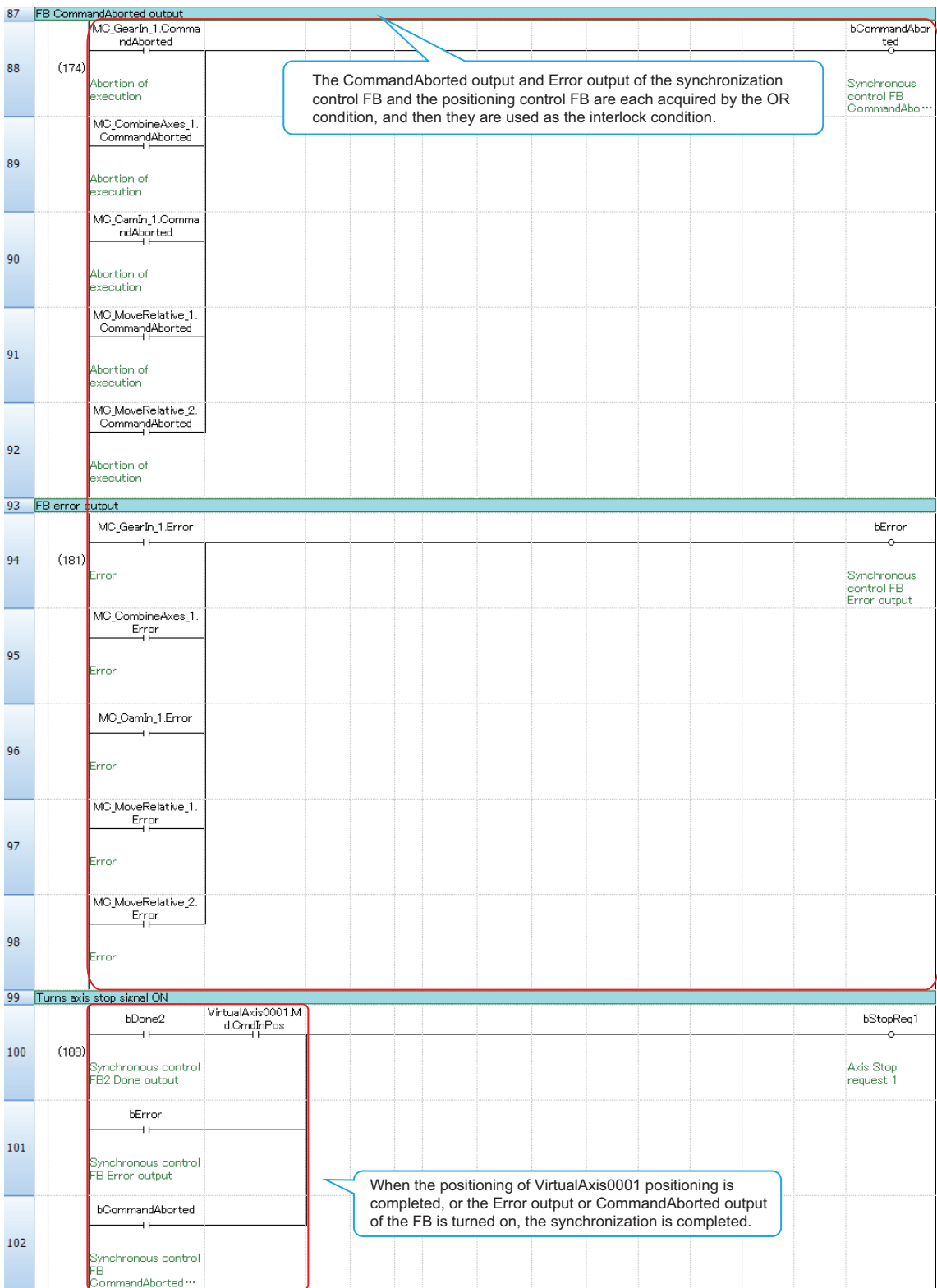

• Synchronization done

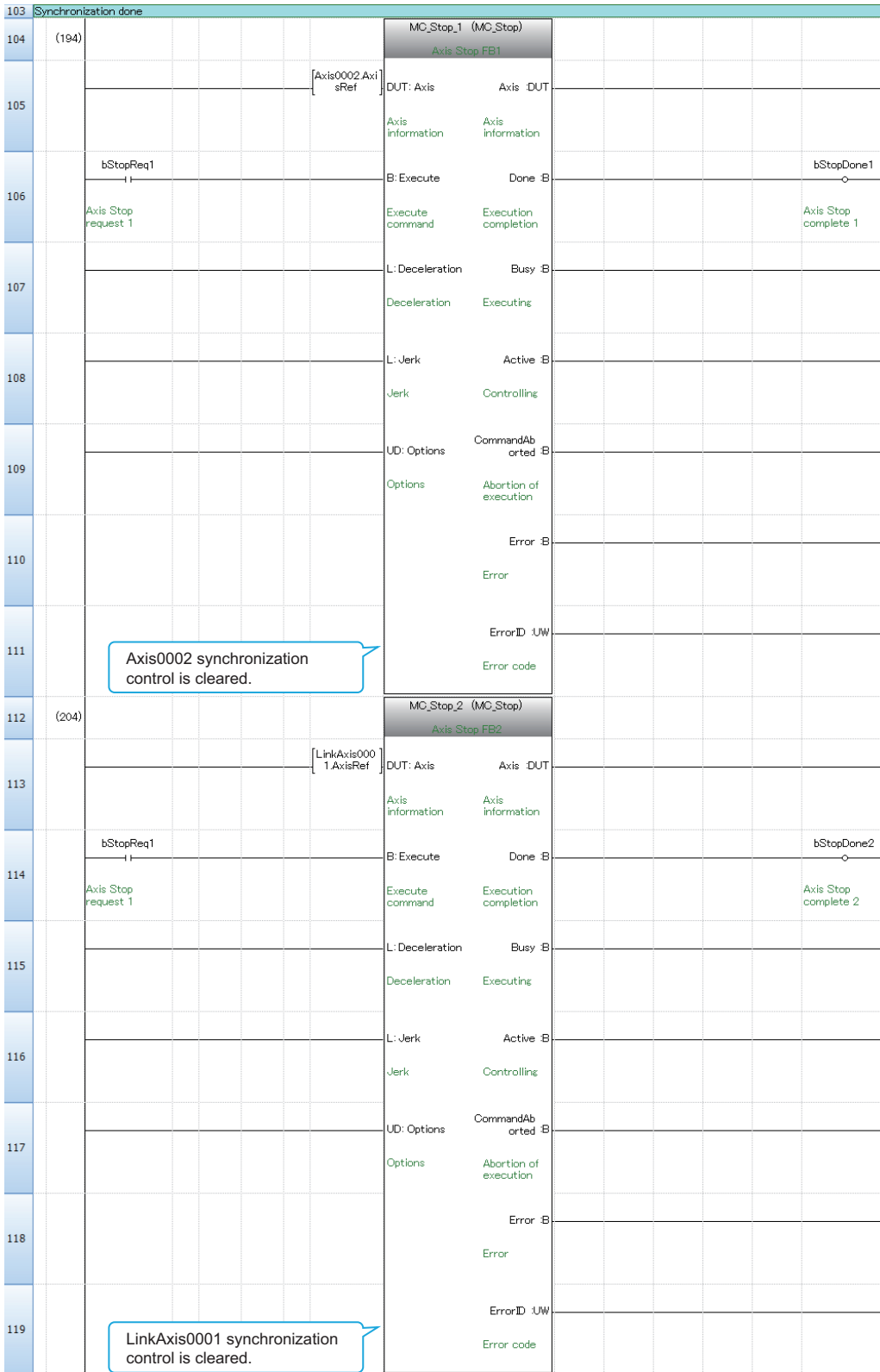

• Synchronization done



- Resets the start request signal when synchronization is completed, Positioning complete signal

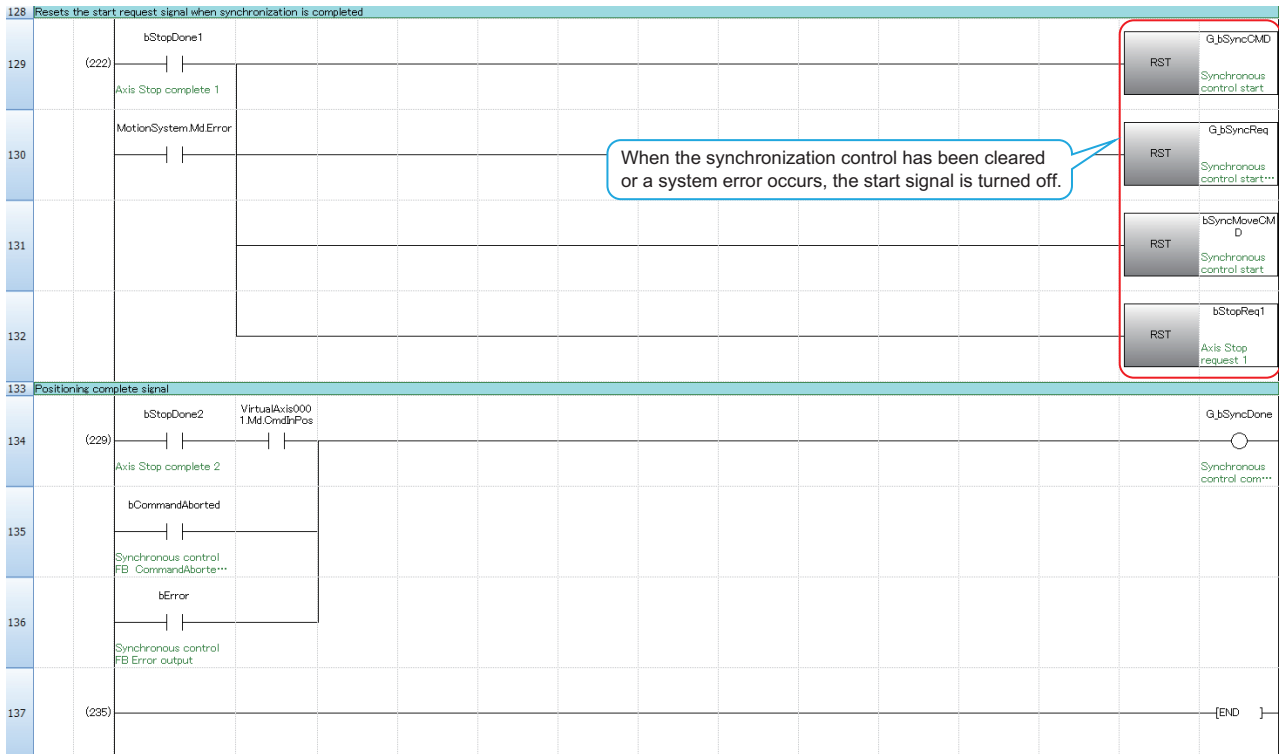

4.12 Error Reset (Program Name: ErrorReset)

This program resets the error on each axis.

FBs used

Type	FB	Description
Administrative	MC_Reset	Resets errors and warnings of the axis.
	MC_GroupReset	Resets errors and warnings of the axes group and each axis in the axes group.
	MCv_MotionErrorReset	Resets all errors and warnings of the motion system.

Local labels

	Label Name	Data Type		Class	English(Display Target)
1	MC_Reset_1	MC_Reset	...	VAR	Axis error reset FB1 Axis0001
2	MC_Reset_2	MC_Reset	...	VAR	Axis error reset FB1 Axis0002
3	MC_Reset_3	MC_Reset	...	VAR	Axis error reset FB1 VirtualAxis0001
4	MC_Reset_4	MC_Reset	...	VAR	Axis error reset FB1 LinkAxis0001
5	MC_Reset_5	MC_Reset	...	VAR	Axis error reset FB1 LinkAxis0002
6	MC_GroupReset_1	MC_GroupReset	...	VAR	Axis group error reset FB
7	MCv_MotionErrorReset_1	MCv_MotionErrorReset	...	VAR	System error reset FB

No.	Description
1 to 7	This label is automatically added when the user drags and drops the FB (MC_Reset, MC_GroupReset, or MCv_MotionErrorReset) onto the program editor.

Program example

The following shows the program example for error reset.

When the error reset label is turned on, MC_Reset and MC_GroupReset are executed.

When the system error reset label is turned on, MCv_MotionErrorReset is executed.

• Axis error reset

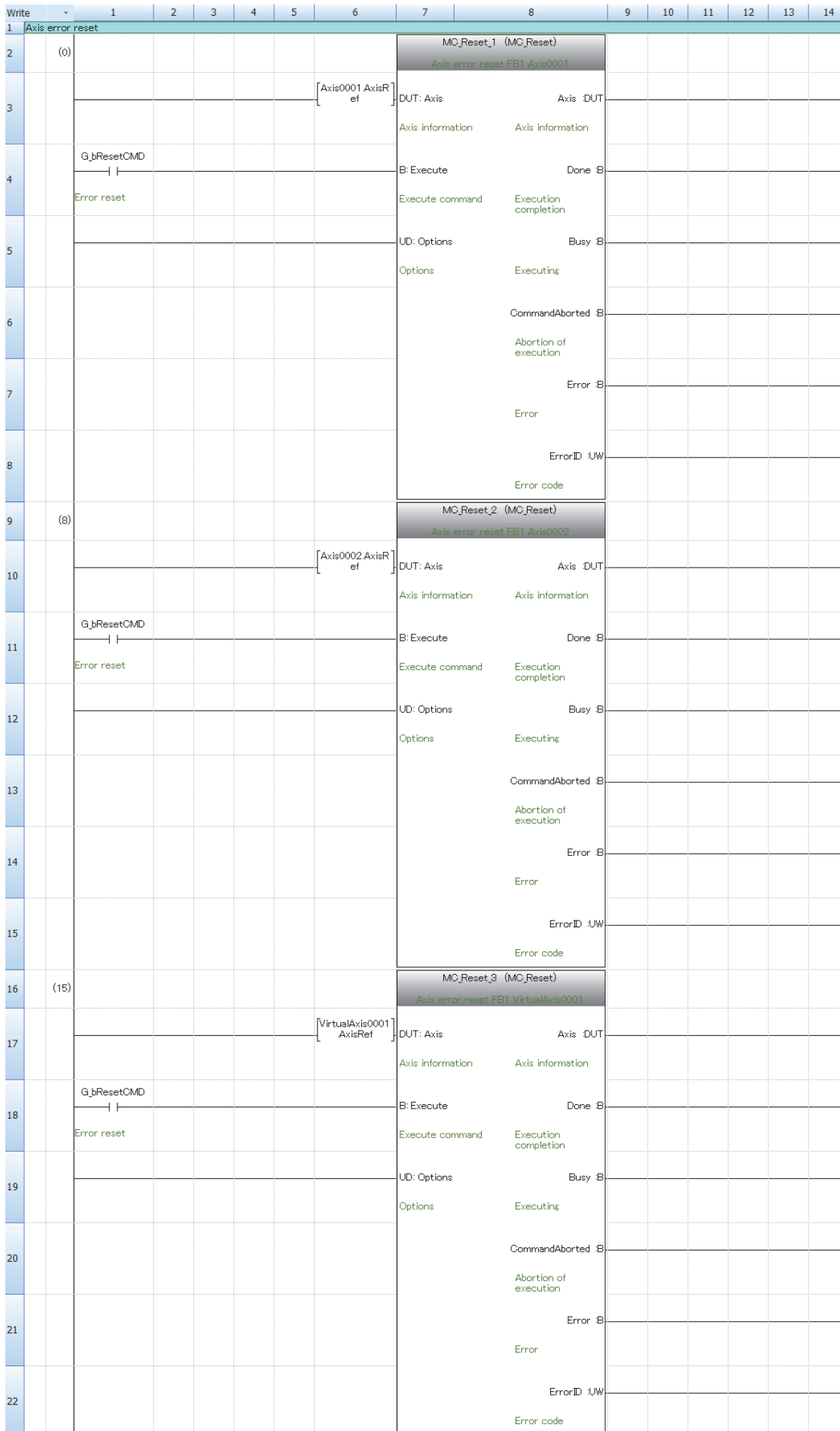



• Axes group error reset, Motion error reset

37		Axes group error reset	
38	(36)		<div style="border: 1px solid black; padding: 5px;"> <p style="text-align: center; margin: 0;">MC_GroupReset_1 (MC_GroupReset)</p> <p style="text-align: center; margin: 0; color: green;">Axes group error reset FB</p> </div>
39		[AxesGroup001] AxesGroupRef	DUT: AxesGroup AxesGroup :DUT Axes group information Axes group information
40		G_bResetCMD Error reset	B: Execute Done B Execute command Execution completion
41			UD: Options Busy B Options Executing
42			CommandAborted B Abortion of execution
43			Error B Error
44			ErrorID :UW Error code
45		Motion error reset	
46	(44)		<div style="border: 1px solid black; padding: 5px;"> <p style="text-align: center; margin: 0;">MCv_MotionErrorReset_1 (MCv_MotionErrorReset)</p> <p style="text-align: center; margin: 0; color: green;">System error reset FB</p> </div>
47			UW: StartIO StartIO :UW I/O Number I/O Number
48		G_bMotionReset CMD System error reset	B: Execute Done B Execute command Execution completion
49			UD: Options Busy B Options Executing
50			CommandAborted B Abortion of execution
51			Error B Error
52			ErrorID :UW Error code
53	(50)		-END-

4.13 Checking Operation

Converting and writing programs

Write the program to the controller.

Operating procedure

1. After creating the programs, select [Convert] ⇒ [Rebuild All] from the menu to convert all the programs.
2. Select [Create Execution Programs after Conversion] in the create executable program and then click the [OK] button.

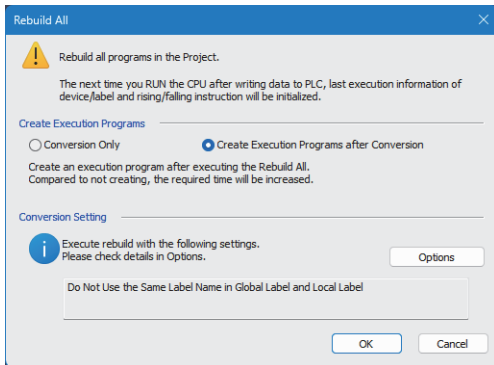

3. Confirm that no error occurs. Select [Online] ⇒ [Write to PLC] in the menu, and write the programs to the controller.

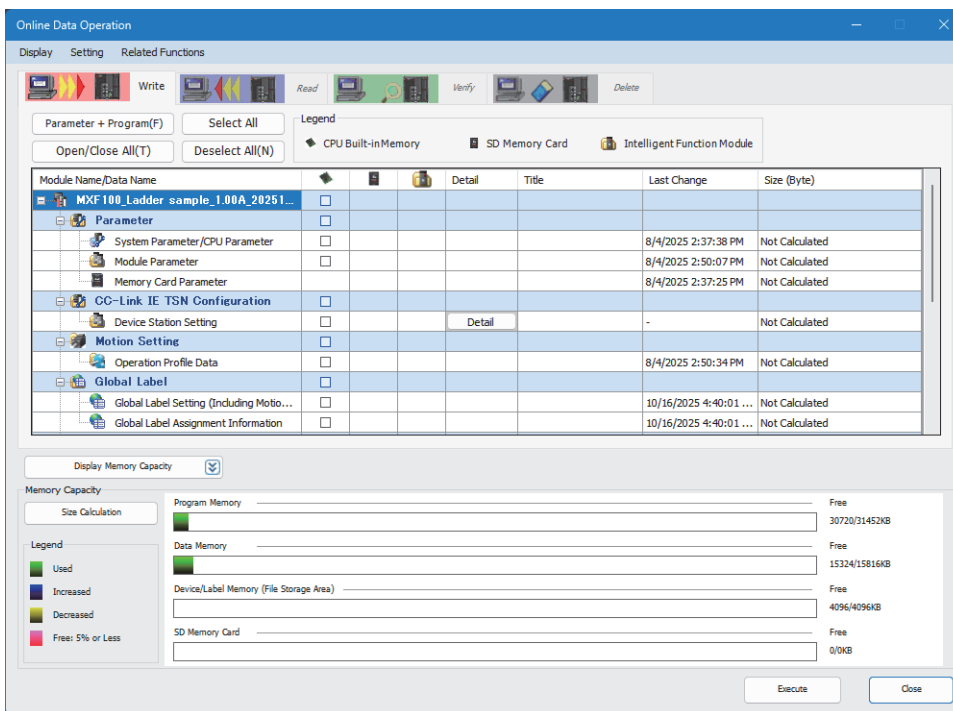

Axis monitor

The axis monitor displays the current values and the error codes of all axes in operation all at once. Users can check the current values and whether any error occurs during the operation.

Displaying the axis monitor window

The following contents are displayed on the axis monitor.

Operating procedure

1. Select [Online] ⇒ [Motion Monitor] ⇒ [Axis Monitor] from the menu bar of the engineering tool.

Displayed contents

The following contents are displayed on the axis monitor.

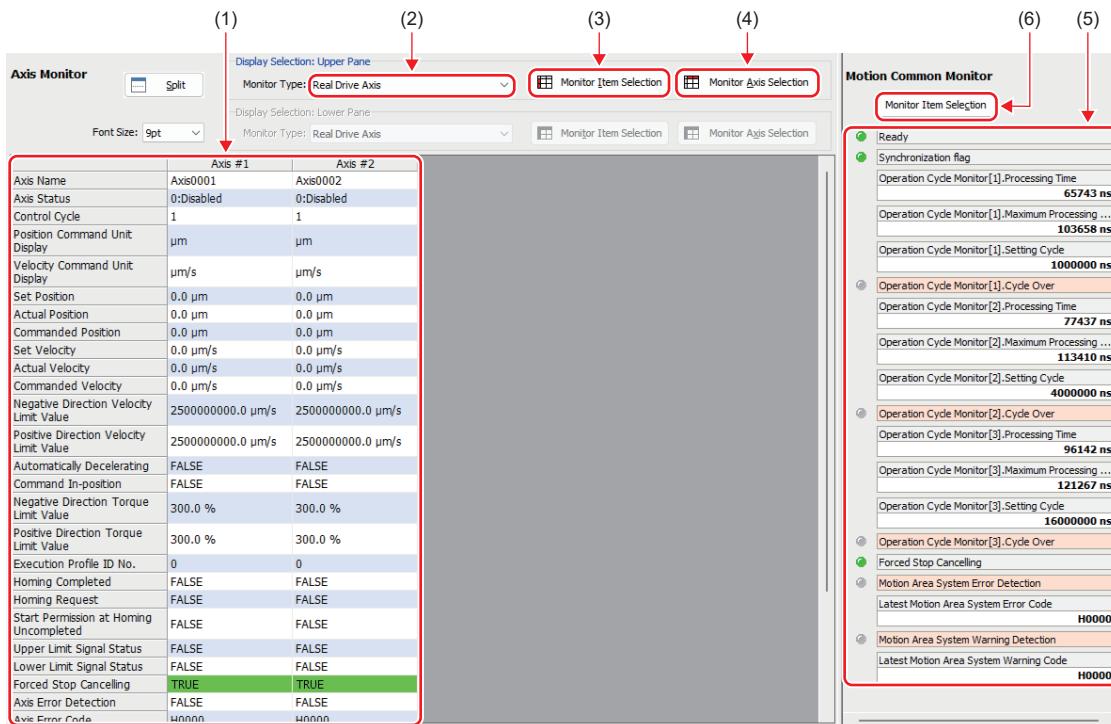

No.	Name	Description
(1)	Axis monitor display items	The monitor items for each axis selected in monitor type are displayed.
(2)	Monitor type	The axis type to monitor can be selected.
(3)	Monitor item selection	Add/delete items to monitor in the axis monitor display items.
(4)	Monitor axis selection	Add/delete axes to monitor in the axis monitor display items.
(5)	System monitor display items	The system monitor items are displayed.
(6)	Monitor item selection	Add/delete items to monitor in the system monitor display items.

Program monitor

The program monitor enables the user to check the current status of the program in execution on the program editor.

Displaying the program monitor window

The program monitor window can be displayed by following the steps below.

- Select [Online] ⇒ [Monitor] ⇒ [Start Monitoring] from the menu bar of the engineering tool.
- Click the "Start Monitoring (All Windows)" icon on the tool bar of the engineering tool.

Watch

The watch function enables the user to check the current values of registered devices and labels.

Register the devices and labels to be monitored to a watch window.

Displaying the watch window

Select [View] ⇒ [Docking Window] ⇒ [Watch 1] to [Watch 4] from the menu in the engineering tool.

Registration of devices/labels/structures to a watch window

Register devices/labels/structures by using the following methods.

- Select the label or structure to register on the program editor, right-click the label or structure, and select [Register to Watch Window] ⇒ [Watch 1] to [Watch 4].
- Enter the device No., label, or structure in the "Name" column of a watch window.

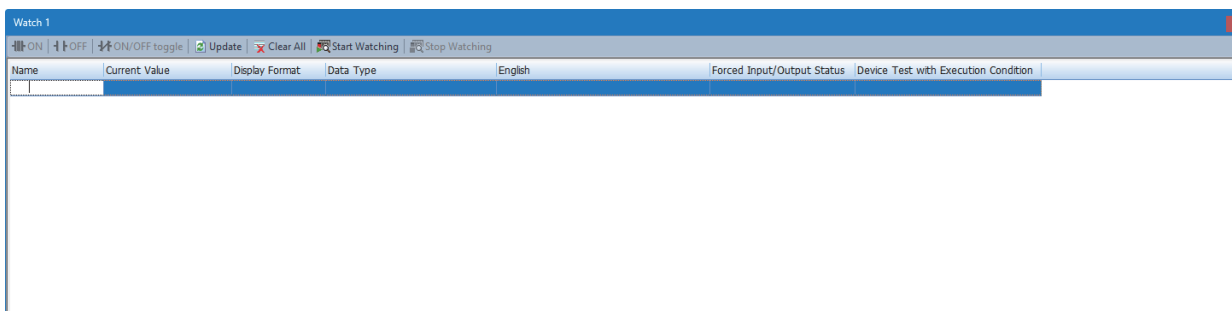

Monitoring start

Select [Online] ⇒ [Watch] ⇒ [Start Watching] from the menu in the engineering tool.

Changing current values

Directly enter a value in "Current Value" during monitoring.

To switch the on/off (TRUE/FALSE) of bit devices or bit type labels, select the row and double-click it with **[Shift]** pressed, or select the row and press both **[Shift]** and **[Enter]**.

Event history

Click [Diagnostics] ⇒ [System Monitor] in the menu of the engineering tool, then click the [Event History] button on the "System Monitor" window to check the event history. If an error occurs, check the details of the error.

The error occurrence time in the event history of the Motion module synchronizes with those recorded in the servo amplifiers. Check the error details of the event history together with the data in the servo amplifier.

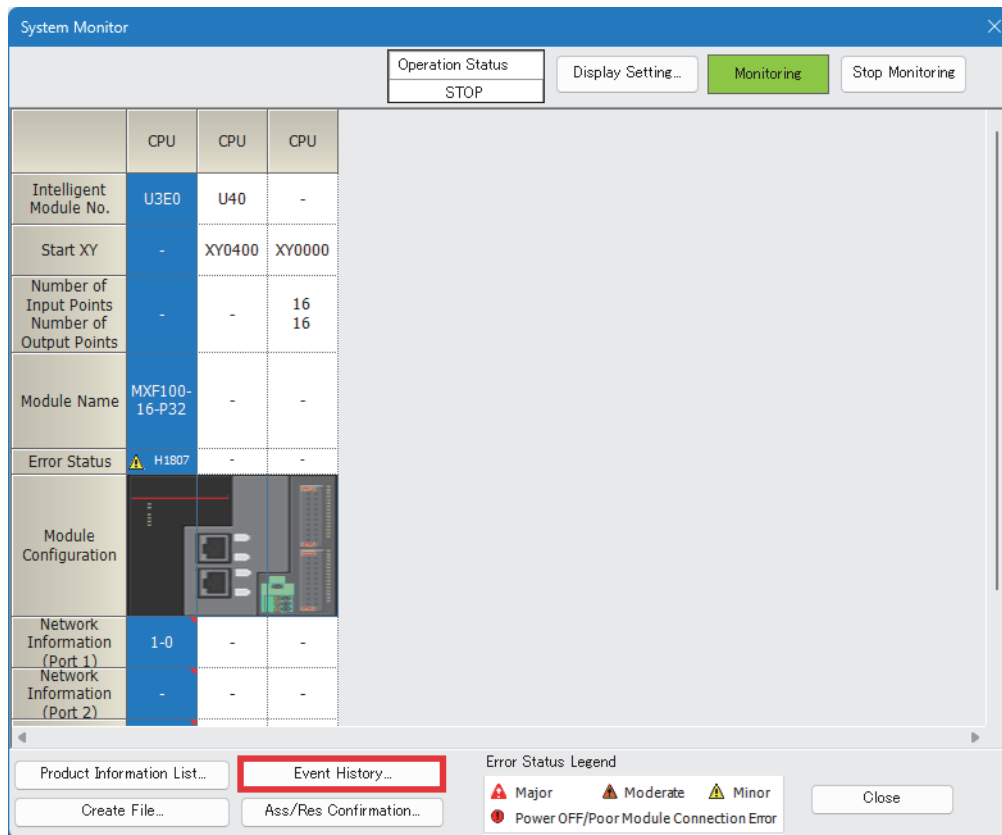

APPENDICES

Appendix 1 Changing the Number of Axes in a Project

The project created in this guide is for the MXF100-16 controller. When using the MXF100-8 controller, the project can be adapted by changing the project's model to an 8-axis controller.

Procedure for changing the number of axes

1. Display the "Change Module Type/Operation Mode" window from the menu of GX Works3.

 [Project] ⇒ [Change Module Type/Operation Mode]

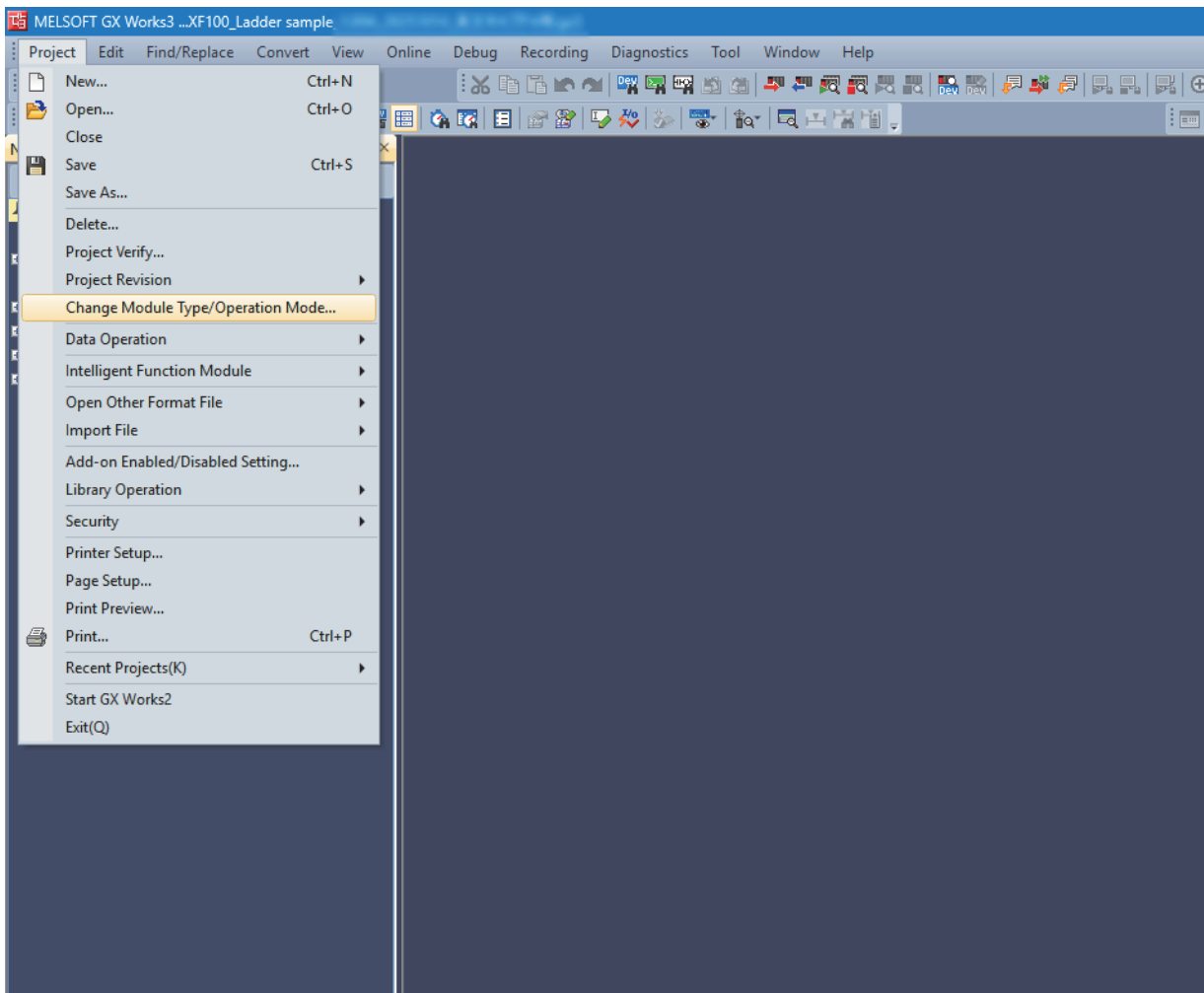

2. Select 8 axes and click the [OK] button.

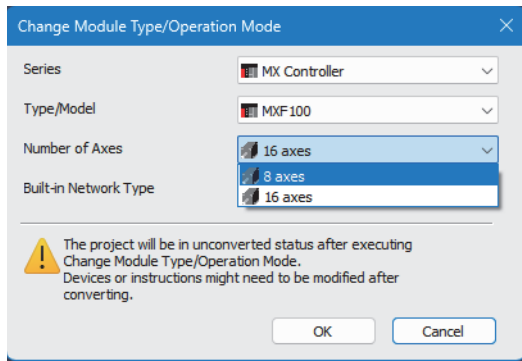

3. After the project conversion, the conversion result will be displayed in the "Output" window.

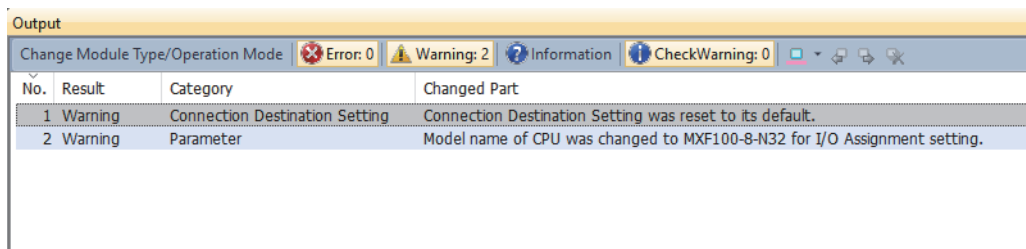

Appendix 2 Using External Input Signals

External input signals can be used for the hardware stroke limit signals and the near-point dog signal.

Available external input signal	Reference
DI signals of the servo amplifier	Page 123 Using the DI signals of the servo amplifier
Input signals of the controller	Page 131 Using the input signals of the controller
Input signals of the remote input module	Page 135 Using the input signals of the remote input module

Using the DI signals of the servo amplifier

This section describes when the LSP/LSN signals of the servo amplifier are used for the hardware stroke limit signals and when homing is executed with the DOG signal of the servo amplifier.

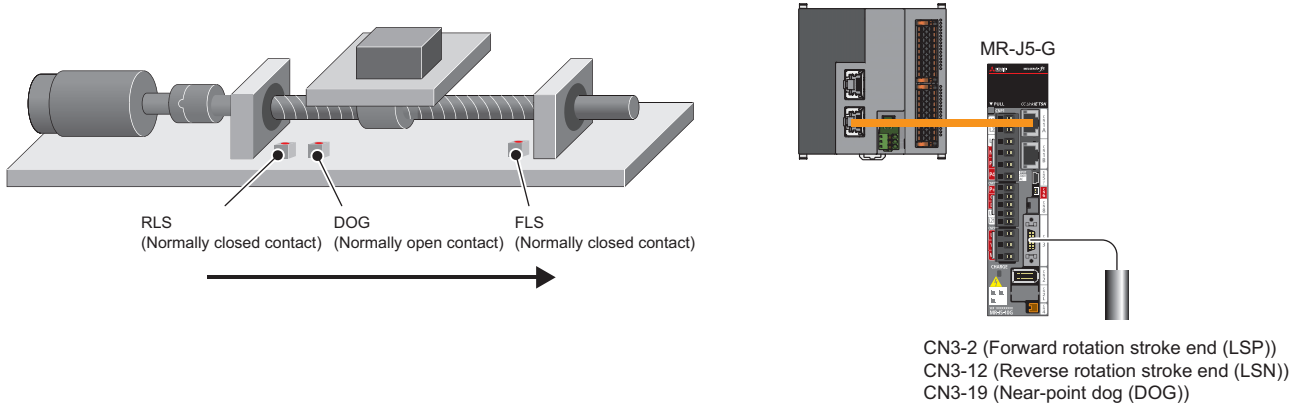

Hardware stroke limit

The negative logic (normally closed contact) is recommended for wiring the hardware stroke limit.

Caution

If the positive logic (normally open contact) is used for the wiring of hardware stroke limit, a serious accident may occur when disconnection or sensor failure occurs.

■ Connection destinations of servo amplifier signals and installation locations of sensors

The installation locations of sensors are changed depending on the setting of the servo parameter [Pr. PA14 (Travel direction selection)]. Set the limit switches connected to the servo amplifier as follows:

[Pr. PA14 (Travel direction selection)]	LSP signal	LSN signal
0 (CCW or positive direction when positioning address increases)	Upper stroke limit of the positioning address increasing side (FLS)	Lower stroke limit of the positioning address decreasing side (RLS)
1 (CW or negative direction when positioning address increases)	Lower stroke limit of the positioning address decreasing side (RLS)	Upper stroke limit of the positioning address increasing side (FLS)

■ Servo parameters

Confirm that the servo parameters are set to the following settings.

No.	Name	Setting value
Pr.PD03.0-1	Device selection DI1	0A (LSP)
Pr.PD04.0-1	Device selection DI2	0B (LSN)
Pr.PD05.0-1	Device selection DI3	22 (DOG)
Pr.PD41.2	Limit switch enabled status selection	1: Enabled only for homing mode
Pr.PD41.3	Sensor input method selection	0: Input from servo amplifier (LSP/LSN/DOG)

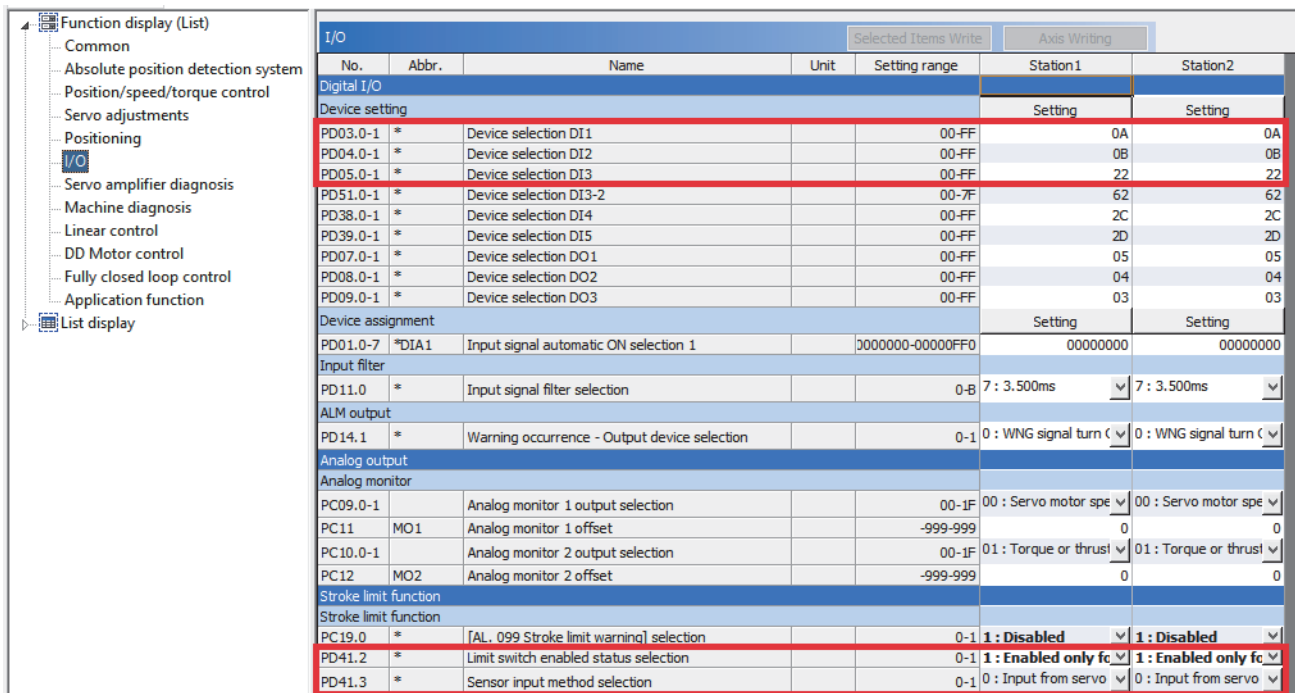

The screenshot shows the 'I/O' parameter configuration screen. The left sidebar lists various function categories, with 'I/O' selected. The main table displays parameters with columns for No., Abbr., Name, Unit, Setting range, Station1, and Station2. Several rows are highlighted in red, indicating the required settings:

- PD03.0-1: Device selection DI1, Setting range 00-FF, Station1 0A, Station2 0A
- PD04.0-1: Device selection DI2, Setting range 00-FF, Station1 0B, Station2 0B
- PD05.0-1: Device selection DI3, Setting range 00-FF, Station1 22, Station2 22
- PD41.2: Limit switch enabled status selection, Setting range 0-1, Station1 1: Enabled only for homing mode, Station2 1: Enabled only for homing mode
- PD41.3: Sensor input method selection, Setting range 0-1, Station1 0: Input from servo, Station2 0: Input from servo

Changing the PDO mapping

1. Double click "<Detailed Setting>" in "PDO Mapping Setting" in the "CC-Link IE TSN Configuration" window.

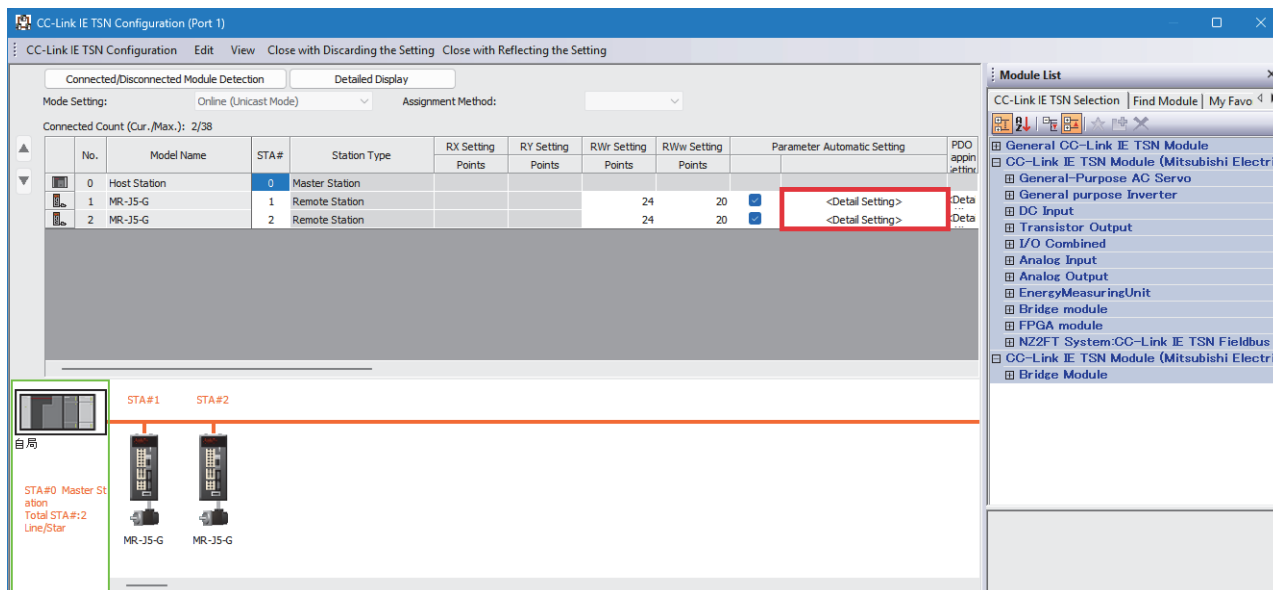

2. Display the "PDO Mapping Setting" window. Set TPDO in the PDO mapping. Select TPDO to display the TPDO list. Set the end of the PDO mapping parameter as follows, then click the [OK] button.

Index (Hex)	Sub-index (Hex)
60fd	00

The entry name will be "Digital inputs" after setting. (The data is the double word type, so it is displayed in two lines.)

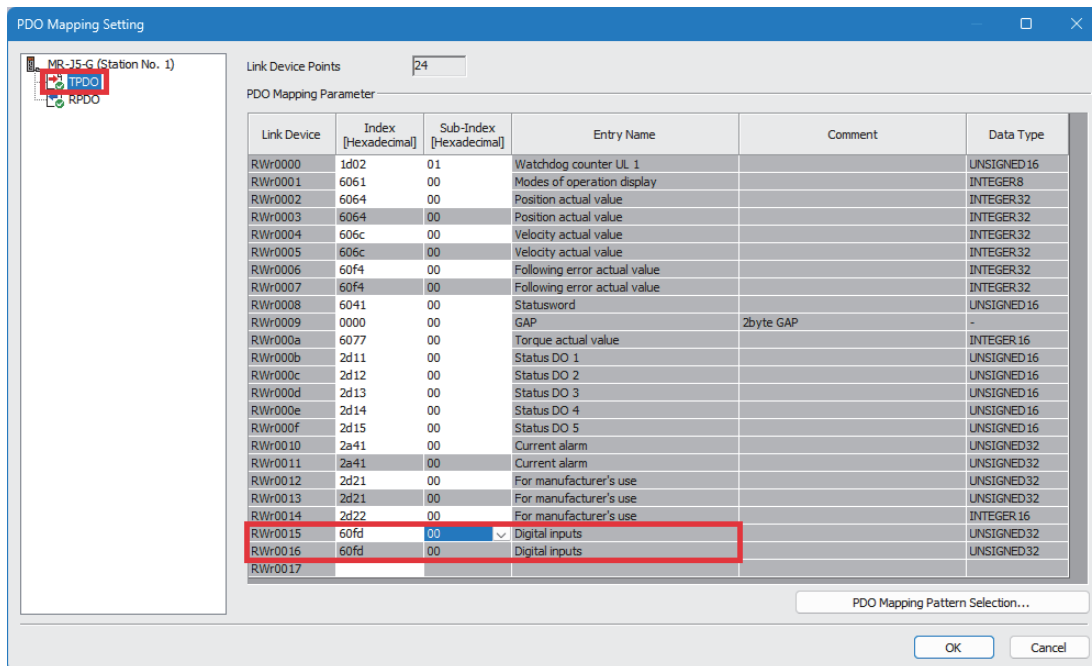

Set as above for all axes that use hardware limit signals connected to the servo amplifier.



"Digital inputs" is a label that stores the status of the servo amplifier input signals.

- bit0: Negative limit switch
- bit1: Positive limit switch

For details, refer to "[Digital inputs (Obj. 60FDh)]" below.

MR-J5-G/MR-J5W-G User's Manual (Object Dictionary)

- After the setting is completed, select [Close with Reflecting the Setting] on the menu bar in the "CC-Link IE TSN Configuration" window. Reflect the data and then close the "CC-Link IE TSN Configuration" window.

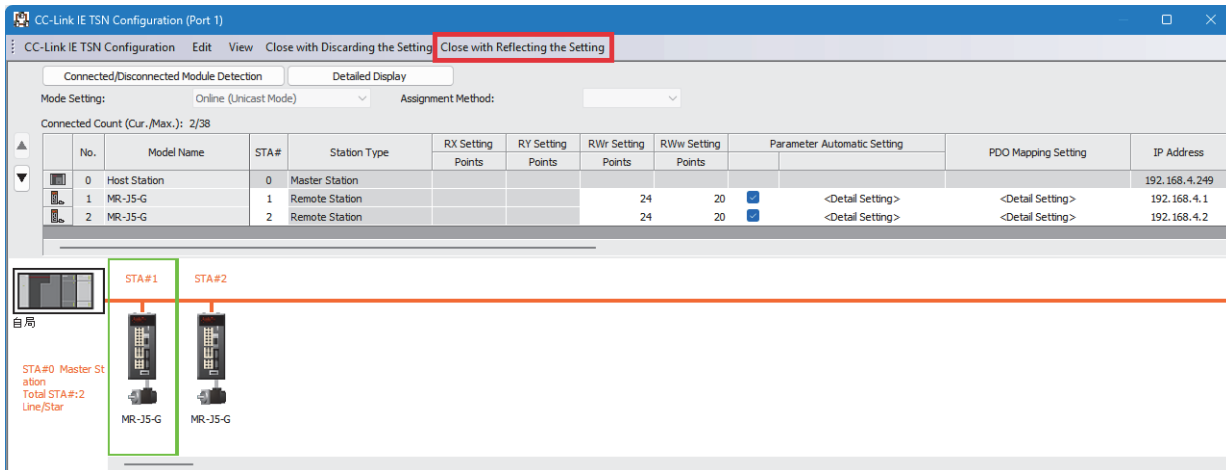

- Click the [Apply] button to reflect the parameters of the controller in the parameter editor (module parameters).

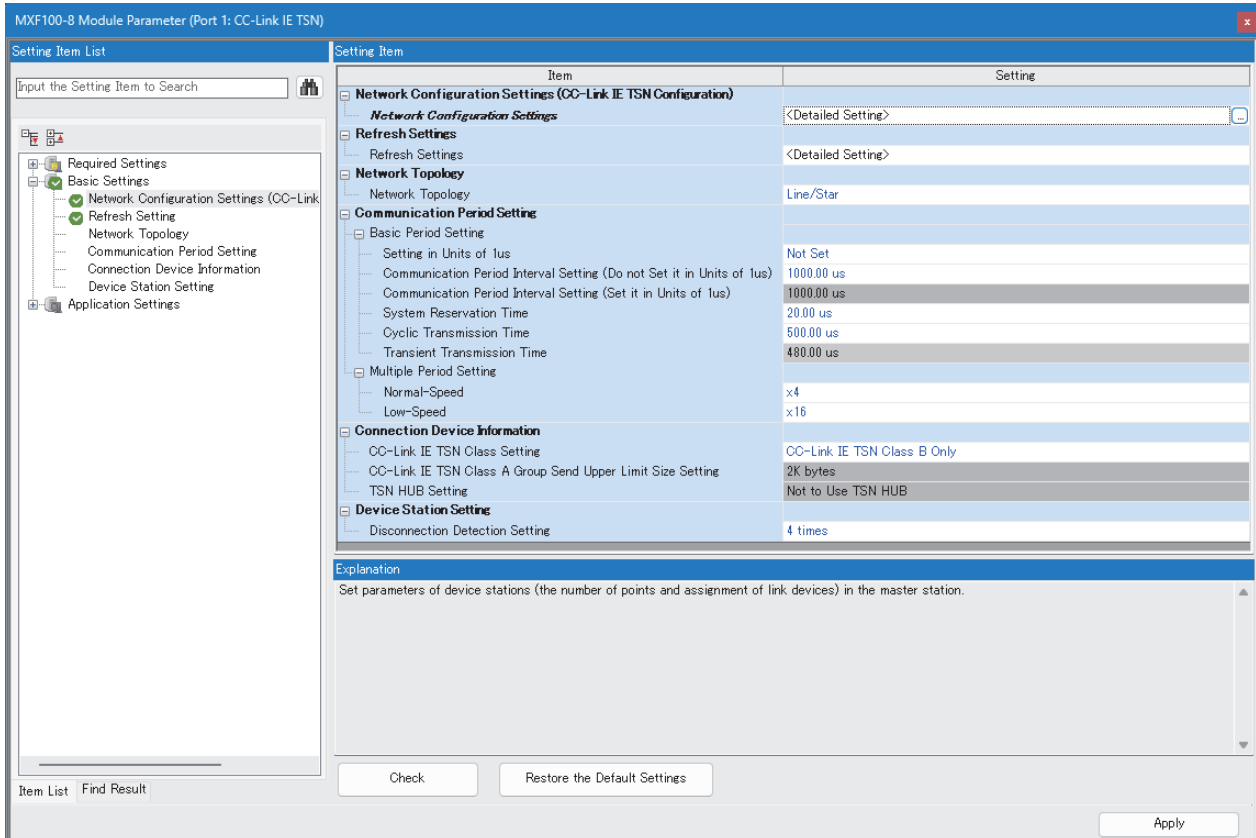

■ Procedure for changing network labels

1. Display the "Network Label Setting" window, and check the boxes of "Labeling Target" for "Data Type" to be labeled.

Navigation window ⇒ Parameter ⇒ Controller ⇒ Module Parameter (CC-Link IE TSN port) ⇒ "Network Label Setting"

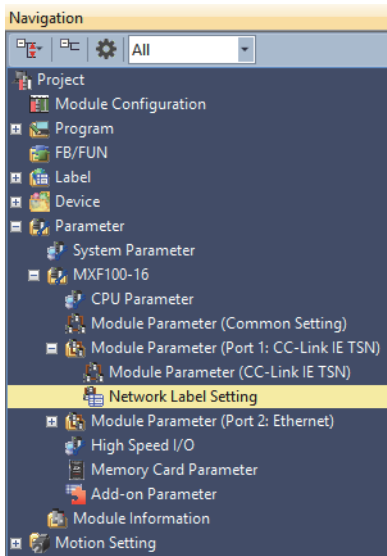

2. Check the boxes of "Labeling Target" of [MR_J5_G_001_DigitalInputs] (the label of the servo amplifier with the hardware stroke limit connected), then click the [Create Label] button.

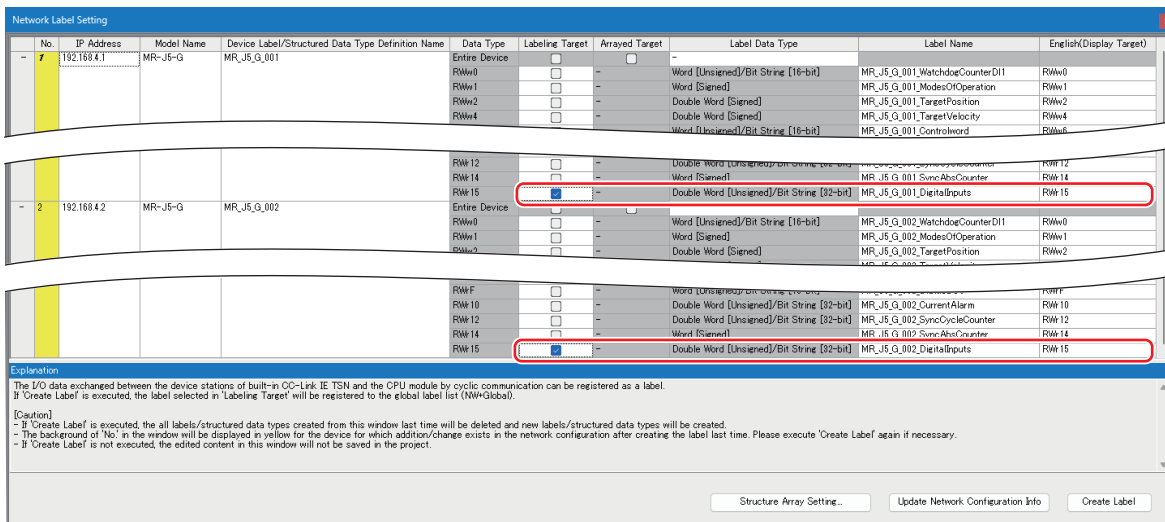

- When the confirmation message appears, click the [Yes] button. "NW+Global1" is added to "Global Label" in the navigation window. The network I/O label is created and stored in "NW+Global1".

MELSOFT GX Works3

Start creating the label on the basis of the setting content.
Are you sure you want to continue?

Yes No

Navigation

- Project
- Module Configuration
- Program
- FB/FUN
- Label
 - Global Label
 - Global
 - En+ Global
 - MotionSys+ Global
 - Addon+ Global
 - Ax+ Global
 - Gr+ Global
 - Prf+ Global
 - NW+ Global1**
- Structured Data Types

	Label Name	Data Type	Class	English(Display Target)
1	MR_J5_G_001_DigitalInputs	Double Word [Unsigned]/Bit String [32-bit]	VAR_GLOBAL	RWr15
2	MR_J5_G_002_DigitalInputs	Double Word [Unsigned]/Bit String [32-bit]	VAR_GLOBAL	RWr15
3				

- Open the axis parameter of the real drive axis.
Double-click "Axis" ⇒ "Axis name to be used (initial value: Axis0001)" in the navigation window.
Display the "Axis Parameter Setting" window. Select "Real Drive Axis" ⇒ "Upper Limit Signal" ⇒ "Target" and click the [...] button.

Axis Parameter Setting

Setting Item List

Input the Setting Item to Search

Select Folder

Display All Data

Real Drive Axis

- Axis Information
- Axis No.
- Basic Parameter
- Limit Parameter
 - Torque Limit Maximum Value
 - Negative Direction Torque Limit
 - Positive Direction Torque Limit
 - Upper Limit Signal
 - Lower Limit Signal
 - Signal
 - Target
- Velocity Limit
- Homing
- Stop
- Stroke Limit
- Driver
- Other
- Real Encoder Axis
- Virtual Drive Axis
- Virtual Encoder Axis
- Virtual Linked Axis

Item	Axis0001	Axis0002
Limit Parameter		
Torque Limit Maximum Value	1000.0 %	1000.0 %
Negative Direction Torque Limit Initial Value	300.0 %	300.0 %
Positive Direction Torque Limit Initial Value	300.0 %	300.0 %
Upper Limit Signal		
Signal		
Target		
Signal Detection Method	0:Detection at TRUE	0:Detection at TRUE
Compensation Time	0.0 s	0.0 s
Filter Time	0.0 s	0.0 s
Lower Limit Signal		
Signal		
Target		
Signal Detection Method	0:Detection at TRUE	0:Detection at TRUE
Compensation Time	0.0 s	0.0 s
Filter Time	0.0 s	0.0 s

Explanation

Specify the signal to be used in control with the following string format.
[Classification] (Type) Data name.Bit position@Target modification
or
[Classification] (Type) WSTRING type label

Example)
When using DINT type to specify a CANopen object:[OBJ](DINT)0:607A0020
When using BOOL type to specify a label:[VAR](BOOL)ADunit10.OutputEnable
When using BOOL type to specify a device:[DEV](BOOL)M0

Restore the Default Settings

Apply

5. Display the "Target Setting" window. Enter "MR_J5_G_***_DigitalInputs.1" into the source.

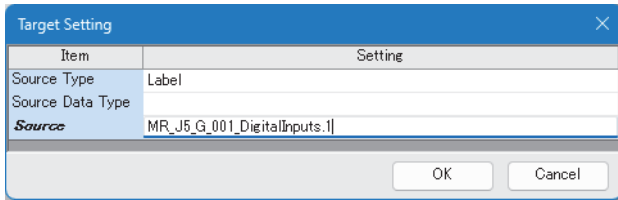

6. In the same way, enter "MR_J5_G_***_DigitalInputs.0" into the source in the "Target Setting" window of the lower limit signal.

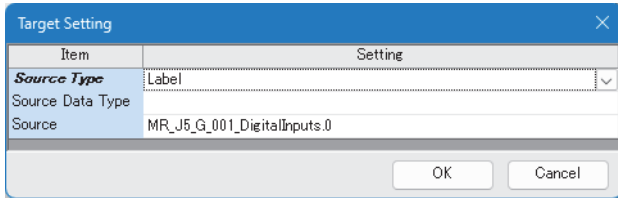

7. Set steps 5 to 6 for all axes using the hardware limit signals connected to the servo amplifier. Note not to confuse the relationship between the axis label and the actual servo amplifier.

To use a normally closed contact, change the signal detection method to "1: Detection at FALSE".

Item	Axis0001	Axis0002
Limit Parameter	Set Limit Parameter	
Torque Limit Maximum	1000.0 %	1000.0 %
Negative Direction Torq	300.0 %	300.0 %
Positive Direction Torq	300.0 %	300.0 %
Upper Limit Signal		
Signal		
Target	[VAR]MR_J5_G_001_DigitalIn	[VAR]MR_J5_G_002_DigitalIn
Signal Detection Met	1:Detection at FALSE	1:Detection at FALSE
Compensation Time	0.0 s	0.0 s
Filter Time	0.0 s	0.0 s
Lower Limit Signal		
Signal		
Target	[VAR]MR_J5_G_001_DigitalIn	[VAR]MR_J5_G_002_DigitalIn
Signal Detection M	1:Detection at FALSE	1:Detection at FALSE
Compensation Time	0.0 s	0.0 s
Filter Time	0.0 s	0.0 s

8. The settings are now completed. Convert all the programs.

■Operation check

Write the program and check whether the on/off status of each signal can be monitored with "Upper Limit Signal Status" and "Lower Limit Signal Status" on the axis monitor.

To return to within the limit range, reset an error once, and then return to the range by the JOG operation or other operations.

Homing using the DOG signal

The following describes the use of DOG signal from the servo amplifier as Homing Switch in the near-point dog signal method.

■ Servo parameters

Set the homing method and the polarity of the near-point dog signal using the following parameters.

No.	Name
Pr.PT29.0	Device input polarity 1
Pr.PT45	Homing method

Set the required parameters from the following according to the homing method.

(The parameters that are required to be set depend on the homing method.)

No.	Name
Pr.PT05	Homing speed
Pr.PT06	Creep speed
Pr.PT07	Home position shift distance
Pr.PT08	Homing position data
Pr.PT09	Movement amount after near-point dog signal
Pr.PT55.0	Homing deceleration time constant selection
Pr.PT56	Homing acceleration time constant
Pr.PT57	Homing deceleration time constant

■ Program

For programs that use the DOG signal of the servo amplifier, the AbsSwitch input of MC_Home is omitted.

Write	1	2	3	4	5	6	7	8	9	10	11	12	13	14
1	(O)						MC_Home_1 (MC_Home)							
2						[Axis0001.AxisRef]	DUT: Axis	Axis · DUT						
							Axis information	Axis information						
3		G_bHoming1Req					B: Execute	Done B						
		Homing Request Axis0001					Execute command	Execution completion						
4						[E0]	L: Position	Busy B						
							Target position	Executing						
5							DUT: AbsSwitch	Active B						
							Home position switch	Controlling						
6							UD: Options	CommandAborted B						
							Options	Abortion of execution						
7								Error B						
								Error						
8								ErrorID · UW						
								Error code						

■ Operation check

Write the program, then check that homing is correctly executed with the specified homing method.

Using the input signals of the controller

This section describes when the input signals of the controller are used for the hardware stroke limit signal and the near-point dog signal.

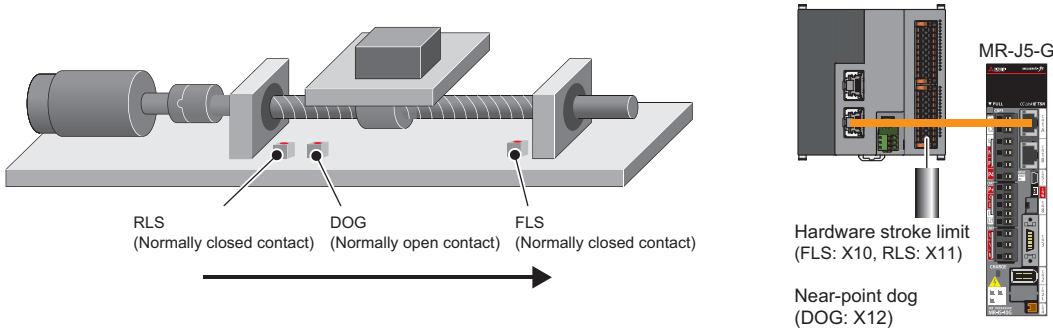

Hardware stroke limit

The negative logic (normally closed contact) is recommended for wiring the hardware stroke limit.

Caution

If the positive logic (normally open contact) is used for the wiring of hardware stroke limit, a serious accident may occur when disconnection or sensor failure occurs.

In this example, "X10" is used as the FLS signal, and "X11" is used as the RLS signal.

Installation location of the sensors

Set the upper stroke limit (FLS) to the positioning address increasing side, and set the lower stroke limit (RLS) to the positioning address decreasing side.

Servo parameters

Set the following servo parameters as follows:

No.	Name	Setting value
Pr.PD41.2	Limit switch enabled status selection	1: Enabled only for homing mode
Pr.PD41.3	Sensor input method selection	1: Input from controller (C_LSP/C_LSN/C_DOG)

I/O					Selected Items Write	Axis Writing	Station1
No.	Abbr.	Name	Unit	Setting range			Setting
Device assignment							
PD01.0-7	*DIA1	Input signal automatic ON selection 1		00000000-00000FF0			00000000
Input filter							
PD11.0	*	Input signal filter selection		0-B			7 : 3.500ms
ALM output							
PD14.1	*	Warning occurrence - Output device selection		0-1			0 : WNG signal turn ON
Analog output							
Analog monitor							
PC09.0-1		Analog monitor 1 output selection		00-1F			00 : Servo motor speed (±8V/max. speed)
PC11	MO1	Analog monitor 1 offset		-999-999			0
PC10.0-1		Analog monitor 2 output selection		00-1F			01 : Torque or thrust (±8V/max. torque or max. thrust)
PC12	MO2	Analog monitor 2 offset		-999-999			0
Stroke limit function							
Stroke limit function							
PC19.0	*	[AL. 099 Stroke limit warning] selection		0-1			1 : Disabled
PD41.2	*	Limit switch enabled status selection		0-1			1 : Enabled only for homing mode
PD41.3	*	Sensor input method selection		0-1			1 : Input from controller (C_FLS/C_RLS/C_DOG)

■Axis parameters of the motion module

In the "Axis Parameter Setting" window, set the target of the "Upper Limit Signal" and "Lower Limit Signal" as follows:

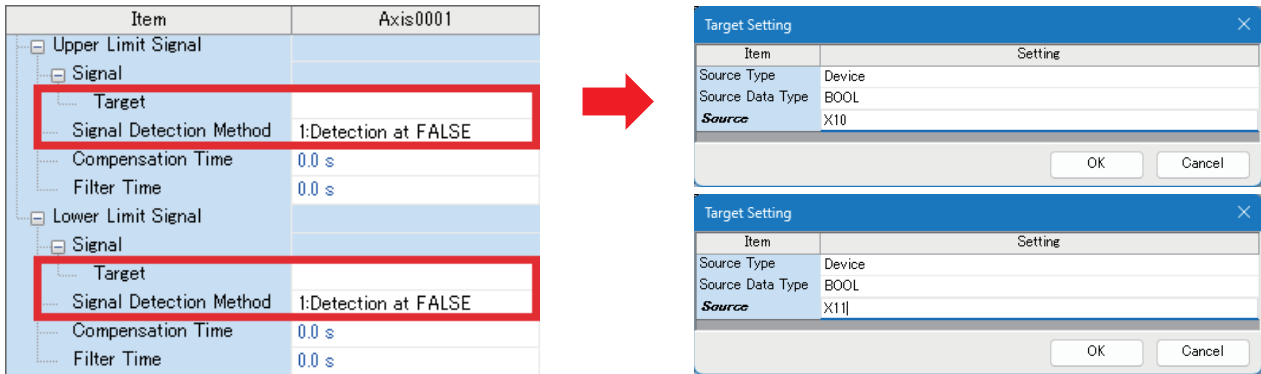

The image shows the "Axis Parameter Setting" window for Axis0001. The "Upper Limit Signal" and "Lower Limit Signal" sections are expanded, and the "Signal Detection Method" is set to "1:Detection at FALSE". A red arrow points to two "Target Setting" dialog boxes. The top dialog box shows the settings for the Upper Limit Signal: Source Type is Device, Source Data Type is BOOL, and Source is X10. The bottom dialog box shows the settings for the Lower Limit Signal: Source Type is Device, Source Data Type is BOOL, and Source is X11.

Item	Axis0001
Upper Limit Signal	
Signal	
Target	
Signal Detection Method	1:Detection at FALSE
Compensation Time	0.0 s
Filter Time	0.0 s
Lower Limit Signal	
Signal	
Target	
Signal Detection Method	1:Detection at FALSE
Compensation Time	0.0 s
Filter Time	0.0 s

Item	Setting
Source Type	Device
Source Data Type	BOOL
Source	X10

Item	Setting
Source Type	Device
Source Data Type	BOOL
Source	X11

Set as above for all axes that use hardware stroke limit signals.

To use a normally closed contact, change the signal detection method to "1: Detection at FALSE".

■Operation check

Write the program and check whether the on/off status of each signal can be monitored with "Upper Limit Signal Status" and "Lower Limit Signal Status" on the axis monitor.

To return to within the limit range, reset an error once, and then return to the range by the JOG operation or other operations.

Homing using the DOG signal

In this example, "X12" is used as the DOG signal.

■ Servo parameters

Set the homing method and the polarity of the near-point dog signal using the following parameters.

No.	Name
Pr.PT29.0	Device input polarity 1
Pr.PT45	Homing method

Set the required parameters from the following according to the homing method.

(The parameters that are required to be set depend on the homing method.)

No.	Name
Pr.PT05	Homing speed
Pr.PT06	Creep speed
Pr.PT07	Home position shift distance
Pr.PT08	Homing position data
Pr.PT09	Movement amount after near-point dog signal
Pr.PT55.0	Homing deceleration time constant selection
Pr.PT56	Homing acceleration time constant
Pr.PT57	Homing deceleration time constant

■ Structures

Prepare the MC_INPUT_REF type structure for the controller label.

The label registration location (global label or local label) is optional. In this example, the label name is "DOG".

	Label Name	Data Type		Class	English(Display Target)
1	DOG	MC_INPUT_REF	...	VAR_GLOBAL	
2			...		

Program

1. Set the members of the MC_INPUT_REF type structure with the program.

- Set the start I/O number of the motion module in "DOG.Signal.Source.StartIO".

Set the device name or the public label name with a Unicode character string in "DOG.Signal.Source.Target".

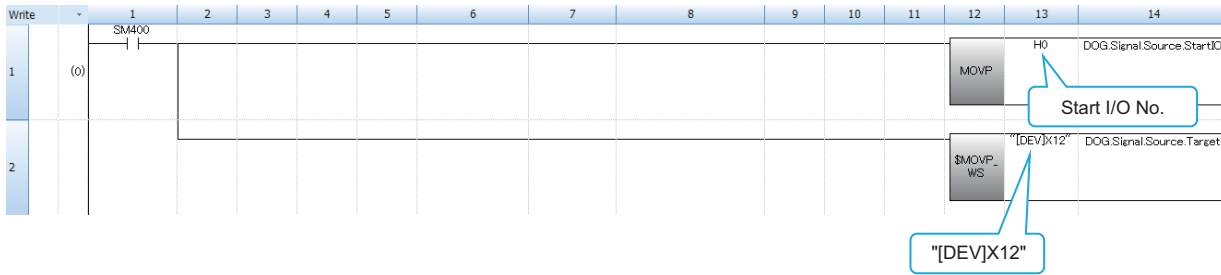

2. Write MC_Home to the program.

- Enter "DOG" (the label of the MC_INPUT_REF type structure set above) into the AbsSwitch input of MC_Home.

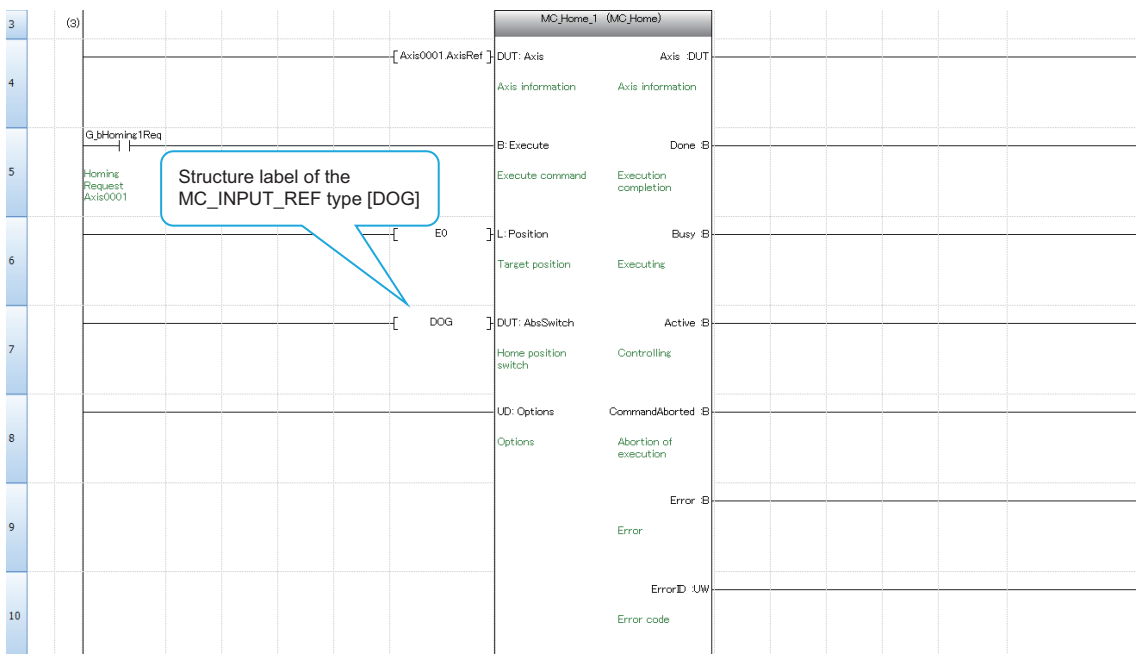

Operation check

Write the program, then check that homing is correctly executed with the specified homing method.

Using the input signals of the remote input module

This section describes when the remote input module is used for the hardware stroke limit signal and the near-point dog signal.

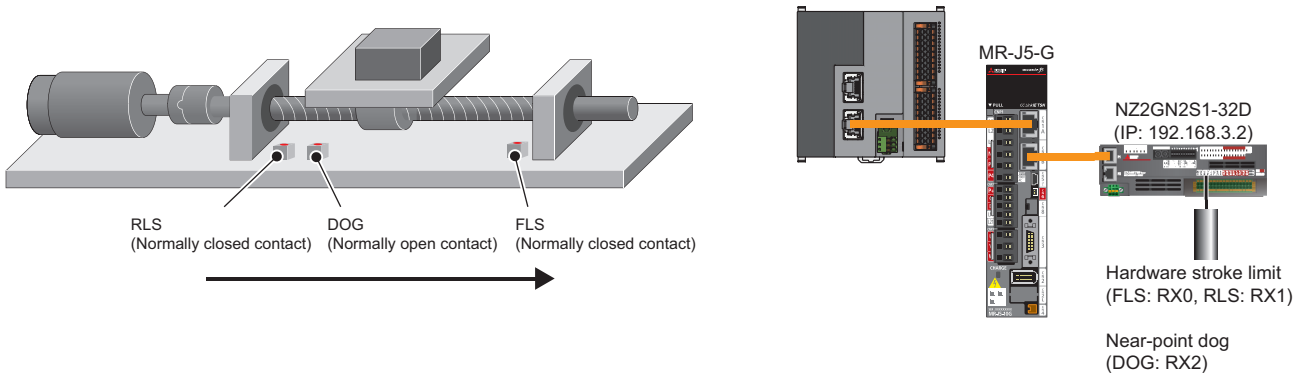

Hardware stroke limit

The negative logic (normally closed contact) is recommended for wiring the hardware stroke limit.

Caution

If the positive logic (normally open contact) is used for the wiring of hardware stroke limit, a serious accident may occur when disconnection or sensor failure occurs.

In this example, "RX0" is used as the FLS signal, and "RX1" is used as the RLS signal.

Installation location of the sensors

Set the upper stroke limit (FLS) to the positioning address increasing side, and set the lower stroke limit (RLS) to the positioning address decreasing side.

Servo parameters

Set the following servo parameters as follows:

No.	Name	Setting value
Pr.PD41.2	Limit switch enabled status selection	1: Enabled only for homing mode
Pr.PD41.3	Sensor input method selection	1: Input from controller (C_LSP/C_LSN/C_DOG)

I/O		Selected Items Write	Axis Writing	
No.	Abbr.	Name	Unit	Setting range
Device assignment				Station1
Setting				Setting
PD01.0-7	*DIA1	Input signal automatic ON selection 1		00000000-0000FF0
Input filter				00000000
PD11.0	*	Input signal filter selection		0-B 7: 3.500ms
ALM output				
PD14.1	*	Warning occurrence - Output device selection		0-1 0: WNG signal turn ON
Analog output				
Analog monitor				
PC09.0-1		Analog monitor 1 output selection		00-1F 00: Servo motor speed (±8V/max. speed)
PC11	MO1	Analog monitor 1 offset		-999-999 0
PC10.0-1		Analog monitor 2 output selection		00-1F 01: Torque or thrust (±8V/max. torque or max. thrust)
PC12	MO2	Analog monitor 2 offset		-999-999 0
Stroke limit function				
Stroke limit function				
PC19.0	*	[AL. 099 Stroke limit warning] selection		0-1 1: Disabled
PD41.2	*	Limit switch enabled status selection		0-1 1: Enabled only for homing mode
PD41.3	*	Sensor input method selection		0-1 1: Input from controller (C_FLS/C_RLS/C_DOG)

■ Network label

1. Double-click "Network Label Setting" in the navigation window. Label the input signals of the remote input module in the displayed "Network Label Setting" window. Check the boxes of "Labeling Target" of "RX0" and "RX1", then click the [Create Label] button.

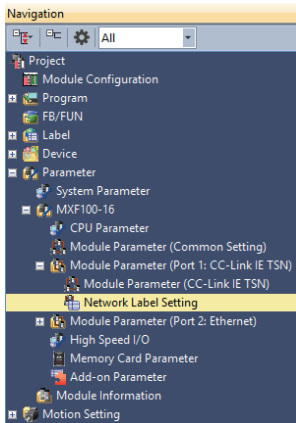

Check [RX0] and [RX1] for a connected remote input module.

No.	IP Address	Model Name	Device Label/Structured Data Type Definition Name	Data Type	Labeling Target	Assigned Target	Label Data Type	Label Name	English (Display Target)
	192.168.4.3	NZ6GNSS1-200	NZ6GNSS1_200_001	Entire Device	<input checked="" type="checkbox"/>	<input type="checkbox"/>	Bit	NZ6GNSS1_200_001_RX0	RX0
					<input checked="" type="checkbox"/>	<input type="checkbox"/>	Bit	NZ6GNSS1_200_001_RX1	RX1
					<input type="checkbox"/>	<input type="checkbox"/>	Bit	NZ6GNSS1_200_001_RX2	RX2
					<input type="checkbox"/>	<input type="checkbox"/>	Bit	NZ6GNSS1_200_001_RX3	External input signal X3
					<input type="checkbox"/>	<input type="checkbox"/>	Bit	NZ6GNSS1_200_001_RX4	External input signal X4
					<input type="checkbox"/>	<input type="checkbox"/>	Bit	NZ6GNSS1_200_001_RX5	External input signal X5
					<input type="checkbox"/>	<input type="checkbox"/>	Bit	NZ6GNSS1_200_001_RX6	External input signal X6
					<input type="checkbox"/>	<input type="checkbox"/>	Bit	NZ6GNSS1_200_001_RX7	External input signal X7
					<input type="checkbox"/>	<input type="checkbox"/>	Bit	NZ6GNSS1_200_001_RX8	External input signal X8
					<input type="checkbox"/>	<input type="checkbox"/>	Bit	NZ6GNSS1_200_001_RX9	External input signal X9
					<input type="checkbox"/>	<input type="checkbox"/>	Bit	NZ6GNSS1_200_001_RXA	External input signal XA
					<input type="checkbox"/>	<input type="checkbox"/>	Bit	NZ6GNSS1_200_001_RXB	External input signal XB
					<input type="checkbox"/>	<input type="checkbox"/>	Bit	NZ6GNSS1_200_001_RXC	External input signal XC
					<input type="checkbox"/>	<input type="checkbox"/>	Bit	NZ6GNSS1_200_001_RXD	External input signal XD
					<input type="checkbox"/>	<input type="checkbox"/>	Bit	NZ6GNSS1_200_001_RXE	External input signal XE
					<input type="checkbox"/>	<input type="checkbox"/>	Bit	NZ6GNSS1_200_001_RXF	External input signal XF
					<input type="checkbox"/>	<input type="checkbox"/>	Bit	NZ6GNSS1_200_001_RXG	External input signal XG
					<input type="checkbox"/>	<input type="checkbox"/>	Bit	NZ6GNSS1_200_001_RXH	External input signal XH
					<input type="checkbox"/>	<input type="checkbox"/>	Bit	NZ6GNSS1_200_001_RXI	External input signal XI
					<input type="checkbox"/>	<input type="checkbox"/>	Bit	NZ6GNSS1_200_001_RXJ	External input signal XJ
					<input type="checkbox"/>	<input type="checkbox"/>	Bit	NZ6GNSS1_200_001_RXK	External input signal XK
					<input type="checkbox"/>	<input type="checkbox"/>	Bit	NZ6GNSS1_200_001_RXL	External input signal XL
					<input type="checkbox"/>	<input type="checkbox"/>	Bit	NZ6GNSS1_200_001_RXM	External input signal XM
					<input type="checkbox"/>	<input type="checkbox"/>	Bit	NZ6GNSS1_200_001_RXN	External input signal XN
					<input type="checkbox"/>	<input type="checkbox"/>	Bit	NZ6GNSS1_200_001_RXO	External input signal XO
					<input type="checkbox"/>	<input type="checkbox"/>	Bit	NZ6GNSS1_200_001_RXP	External input signal XP
					<input type="checkbox"/>	<input type="checkbox"/>	Bit	NZ6GNSS1_200_001_RXQ	External input signal XQ
					<input type="checkbox"/>	<input type="checkbox"/>	Bit	NZ6GNSS1_200_001_RXR	External input signal XR
					<input type="checkbox"/>	<input type="checkbox"/>	Bit	NZ6GNSS1_200_001_RXS	External input signal XS
					<input type="checkbox"/>	<input type="checkbox"/>	Bit	NZ6GNSS1_200_001_RXT	External input signal XT
					<input type="checkbox"/>	<input type="checkbox"/>	Bit	NZ6GNSS1_200_001_RXU	External input signal XU
					<input type="checkbox"/>	<input type="checkbox"/>	Bit	NZ6GNSS1_200_001_RXV	External input signal XV
					<input type="checkbox"/>	<input type="checkbox"/>	Bit	NZ6GNSS1_200_001_RXW	External input signal XW
					<input type="checkbox"/>	<input type="checkbox"/>	Bit	NZ6GNSS1_200_001_RXX	External input signal XX
					<input type="checkbox"/>	<input type="checkbox"/>	Bit	NZ6GNSS1_200_001_RXY	External input signal XY
					<input type="checkbox"/>	<input type="checkbox"/>	Bit	NZ6GNSS1_200_001_RXZ	External input signal XZ

Structure Array Setting **Update Network Configuration Info** **Create Label**

Notes
 The I/O data exchanged between the device stations of built-in CC-Link IE TSN and the CPU module by cyclic communication can be registered as a label.
 If 'Create Label' is executed, the label selected in 'Labeling Target' will be registered to the label list (NWGlobal).
[Caution]
 - If 'Create Label' is executed, the all labels/structured data types created from this window last time will be deleted and new labels/structured data types will be created.
 - The background of No. in the window will be displayed in yellow for the device for which addition/change exists in the network configuration after creating the label last time. Please execute 'Create Label' again if necessary.
 - If 'Create Label' is not executed, the edited content in this window will not be saved in the project.

- After the labels are created, "NW+Global1" will be added in "Global Label" in the navigation window. The network labels are created and stored in "NW+Global1".

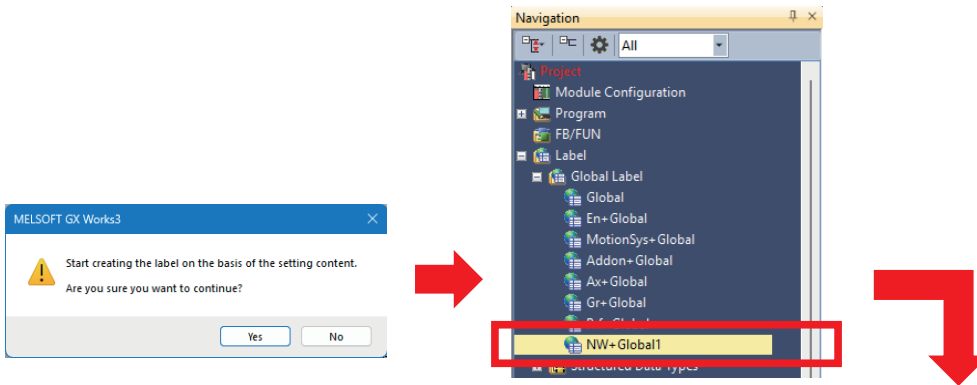

	Label Name	Data Type		Class	English(Display Target)
1	NZ2GN2S1_32D_001_RX0_	Bit	...	VAR_GLOBAL	RX0
2	NZ2GN2S1_32D_001_RX1_	Bit	...	VAR_GLOBAL	RX1
3	NZ2GN2S1_32D_001_RX2_	Bit	...	VAR_GLOBAL	RX2
4					

• Axis parameters

In the "Axis Parameter Setting" window, set the target of the "Upper Limit Signal" and "Lower Limit Signal" as follows:

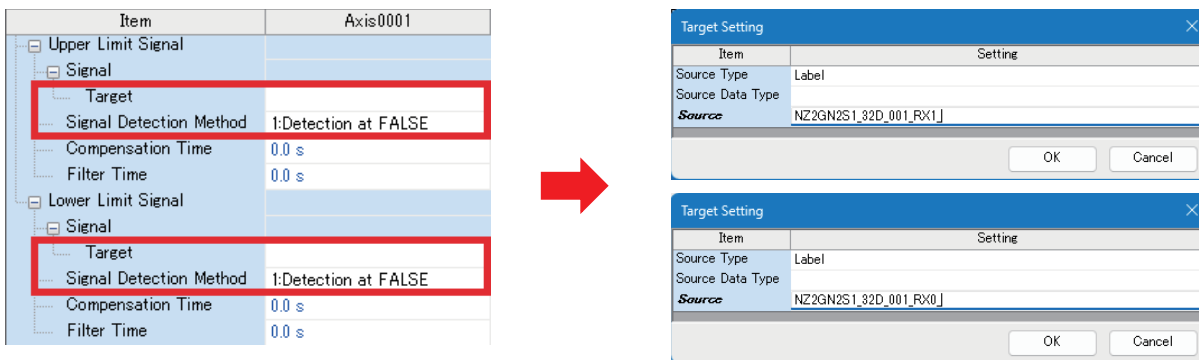

Set as above for all axes that use hardware stroke limit signals.

To use a normally closed contact, change the signal detection method to "1: Detection at FALSE".

■ Operation check

Write the program and check whether the on/off status of each signal can be monitored with "Upper Limit Signal Status" and "Lower Limit Signal Status" on the axis monitor.

To return to within the limit range, reset an error once, and then return to the range by the JOG operation or other operations.

Homing using the DOG signal

In this example, "RX2" is used as the DOG signal.

■ Servo parameters

Set the homing method and the polarity of the near-point dog signal using the following parameters.

No.	Name
Pr.PT29.0	Device input polarity 1
Pr.PT45	Homing method

Set the required parameters from the following according to the homing method.

(The parameters that are required to be set depend on the homing method.)

No.	Name
Pr.PT05	Homing speed
Pr.PT06	Creep speed
Pr.PT07	Home position shift distance
Pr.PT08	Homing position data
Pr.PT09	Movement amount after near-point dog signal
Pr.PT55.0	Homing deceleration time constant selection
Pr.PT56	Homing acceleration time constant
Pr.PT57	Homing deceleration time constant

■ Motion module parameters

- Setting of the network I/O

1. Double-click "Network Label Setting" in the navigation window of Motion Control Setting Function. Label the input signal of the remote input module in the displayed "Network Label Setting" window. Check the box of "Labeling Target" of "RX2", then click the [Create Label] button.

The screenshot shows the 'Network Label Setting' window with a table of input modules. The 'Labeling Target' checkbox for 'RX2' is checked. A callout box points to this checkbox with the text: "Check [RX2] for a connected remote input module."

No.	IP Address	Model Name	Device Label/Structured Data Type Definition Name	Data Type	Labeling Target	Arrayed Target	Label Data Type	Label Name	English/Display Target
1	192.168.4.3	NZ20NS1-200	NZ20NS1_3SD_01	DI	<input checked="" type="checkbox"/>	<input type="checkbox"/>	DI	NZ20NS1_3SD_01_RX01	FX01
				DI	<input checked="" type="checkbox"/>	<input type="checkbox"/>	DI	NZ20NS1_3SD_01_RX02	FX02
				DI	<input type="checkbox"/>	<input type="checkbox"/>	DI	NZ20NS1_3SD_01_RX03	FX03
				DI	<input type="checkbox"/>	<input type="checkbox"/>	DI	NZ20NS1_3SD_01_RX04	FX04
				DI	<input type="checkbox"/>	<input type="checkbox"/>	DI	NZ20NS1_3SD_01_RX05	FX05
				DI	<input type="checkbox"/>	<input type="checkbox"/>	DI	NZ20NS1_3SD_01_RX06	FX06
				DI	<input type="checkbox"/>	<input type="checkbox"/>	DI	NZ20NS1_3SD_01_RX07	FX07
				DI	<input type="checkbox"/>	<input type="checkbox"/>	DI	NZ20NS1_3SD_01_RX08	FX08
				DI	<input type="checkbox"/>	<input type="checkbox"/>	DI	NZ20NS1_3SD_01_RX09	FX09
				DI	<input type="checkbox"/>	<input type="checkbox"/>	DI	NZ20NS1_3SD_01_RX0A	FX0A
				DI	<input type="checkbox"/>	<input type="checkbox"/>	DI	NZ20NS1_3SD_01_RX0B	FX0B
				DI	<input type="checkbox"/>	<input type="checkbox"/>	DI	NZ20NS1_3SD_01_RX0C	FX0C
				DI	<input type="checkbox"/>	<input type="checkbox"/>	DI	NZ20NS1_3SD_01_RX0D	FX0D
				DI	<input type="checkbox"/>	<input type="checkbox"/>	DI	NZ20NS1_3SD_01_RX0E	FX0E
				DI	<input type="checkbox"/>	<input type="checkbox"/>	DI	NZ20NS1_3SD_01_RX0F	FX0F
				DI	<input type="checkbox"/>	<input type="checkbox"/>	DI	NZ20NS1_3SD_01_RX10	FX10
				DI	<input type="checkbox"/>	<input type="checkbox"/>	DI	NZ20NS1_3SD_01_RX11	FX11
				DI	<input type="checkbox"/>	<input type="checkbox"/>	DI	NZ20NS1_3SD_01_RX12	FX12
				DI	<input type="checkbox"/>	<input type="checkbox"/>	DI	NZ20NS1_3SD_01_RX13	FX13
				DI	<input type="checkbox"/>	<input type="checkbox"/>	DI	NZ20NS1_3SD_01_RX14	FX14
				DI	<input type="checkbox"/>	<input type="checkbox"/>	DI	NZ20NS1_3SD_01_RX15	FX15
				DI	<input type="checkbox"/>	<input type="checkbox"/>	DI	NZ20NS1_3SD_01_RX16	FX16
				DI	<input type="checkbox"/>	<input type="checkbox"/>	DI	NZ20NS1_3SD_01_RX17	FX17
				DI	<input type="checkbox"/>	<input type="checkbox"/>	DI	NZ20NS1_3SD_01_RX18	FX18
				DI	<input type="checkbox"/>	<input type="checkbox"/>	DI	NZ20NS1_3SD_01_RX19	FX19
				DI	<input type="checkbox"/>	<input type="checkbox"/>	DI	NZ20NS1_3SD_01_RX1A	FX1A
				DI	<input type="checkbox"/>	<input type="checkbox"/>	DI	NZ20NS1_3SD_01_RX1B	FX1B
				DI	<input type="checkbox"/>	<input type="checkbox"/>	DI	NZ20NS1_3SD_01_RX1C	FX1C
				DI	<input type="checkbox"/>	<input type="checkbox"/>	DI	NZ20NS1_3SD_01_RX1D	FX1D
				DI	<input type="checkbox"/>	<input type="checkbox"/>	DI	NZ20NS1_3SD_01_RX1E	FX1E
				DI	<input type="checkbox"/>	<input type="checkbox"/>	DI	NZ20NS1_3SD_01_RX1F	FX1F

Structure Array Setting... Update Network Configuration Info Create Label

- After the label is created, "NW+Global1" will be added in "Global Label" in the navigation window. The network I/O label is created and stored in "NW+Global1".

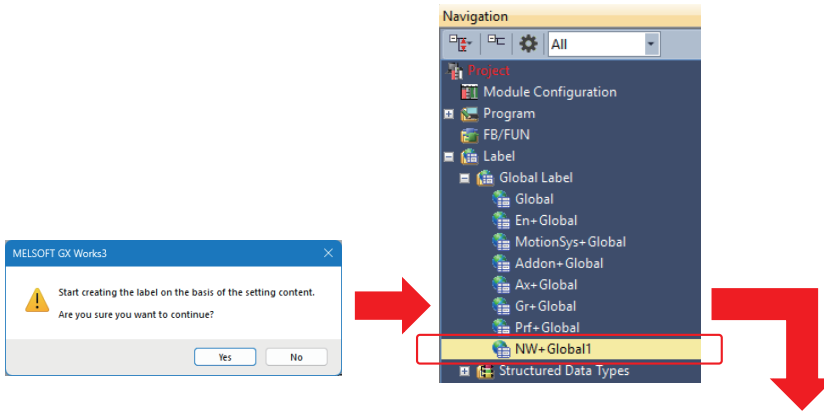

	Label Name	Data Type		Class	English(Display Target)
1	NZ2GN2S1_32D_001_RX0_	Bit	...	VAR_GLOBAL	RX0
2	NZ2GN2S1_32D_001_RX1_	Bit	...	VAR_GLOBAL	RX1
3	NZ2GN2S1_32D_001_RX2_	Bit	...	VAR_GLOBAL	RX2
4			...		

Structures

Prepare the MC_INPUT_REF type structure for the controller label. The label registration location (global label or local label) is optional. In this example, the label name is "DOG".

	Label Name	Data Type		Class	English(Display Target)
22	G_bSysErrorReset	Bit	...	VAR_GLOBAL	System error reset
23	G_bAxis0001 Status	Bit	...	VAR_GLOBAL	Standby Axis0001
24	G_bAxis0001 Status	Bit	...	VAR_GLOBAL	Standby Axis0002
25	DOG	MC_INPUT_REF	...	VAR_GLOBAL	Proximity dog
26			...		

Program

1. Set the members of the MC_INPUT_REF type structure with the program.

- Set the start I/O number of the motion module in "DOG.Signal.Source.StartIO".

Set the label name of "RX2" with a Unicode character string in "DOG.Signal.Source.Target".

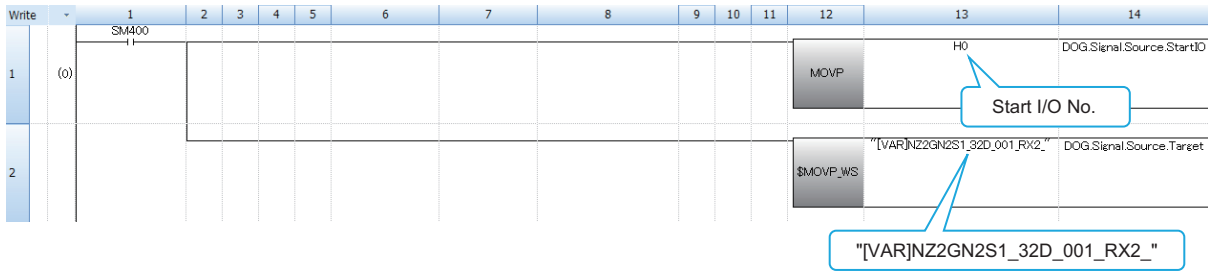

2. Write MC_Home to the program.

- Enter "DOG" (the label of the MC_INPUT_REF type structure set above) into the AbsSwitch input of MC_Home.



Operation check

Write the program, then check that homing is correctly executed with the specified homing method.

Appendix 3 Precautions to Use Absolute Position Detection System

When using in an absolute position detection system, note that the following items.

Servo parameter settings

For the servo parameter, change the following two items.

No.	Name	Setting value
PA03.0	Absolute position detection system selection	"0: Disabled (incremental system)" → "1: Enabled (absolute position detection system)"
PC29.5	[AL. 0E3 Absolute position counter warning] selection	"1: Enabled" → "0: Disabled"

At initial startup

After the absolute position detection system is set, [AL. 025.1 Servo motor encoder absolute position erased] occurs on the servo amplifier at initial startup.

Wait for 5 seconds while the alarm is present, then turn the power on again.

After that, execute homing.

REVISIONS

*The manual number is given on the bottom left of the back cover.

Revision date	*Manual number	Revision
January 2026	L(NA)08983ENG-A	First edition

Japanese manual number: L08982-A

This guide confers no industrial property rights or any rights of any other kind, nor does it confer any patent licenses. Mitsubishi Electric Corporation cannot be held responsible for any problems involving industrial property rights which may occur as a result of using the contents noted in this guide.

© 2026 MITSUBISHI ELECTRIC CORPORATION

L(NA)08983ENG-A(2601)

MITSUBISHI ELECTRIC CORPORATION

HEAD OFFICE: TOKYO BLDG., 2-7-3, MARUNOUCHI, CHIYODA-KU, TOKYO 100-8310, JAPAN
NAGOYA WORKS: 1-14, YADA-MINAMI 5-CHOME, HIGASHI-KU, NAGOYA 461-8670, JAPAN

When exported from Japan, this manual does not require application to the
Ministry of Economy, Trade and Industry for service transaction permission.

Specifications subject to change without notice.