



TECHNICAL BULLETIN

[1 / 36]

[Issue No.] GOT-A-0010-AC

[Title] List of Valid Devices Applicable for GOT1000 Series

[Date of Issue] September 2005 (Ver. AC: December 2019)

[Relevant Models] GOT1000 Series

Thank you for your continued support of Mitsubishi Electric Graphic Operation Terminal (GOT).
The peripheral devices listed in this bulletin have been concluded by Mitsubishi Electric to be applicable for the GOT1000 series.
For how to use each product, refer to the respective product's manual.
Regarding the production status of each product, confirm with the manufacturer.

Recommended Product Products that are compliant with Mitsubishi Electric standards. Use Recommended Products according to their specifications.
Compatible Product Products that are connectable to Mitsubishi Electric products. (Note that compatibility is not verified by Mitsubishi Electric.) Use Compatible Products according to their specifications. Some Compatible Products may not be connected because their specifications have changed depending on the date of manufacture. Verify Compatible Products, and determine whether or not to use the products.
Discontinued Product Recommended Products or Compatible Products that have been mentioned in the bulletin before, but may be difficult to procure because they have been discontinued.
Incompatible Product Products that are not connectable to Mitsubishi Electric products. Use Compatible Products.

Contents

1. Memory Card (CF card and SD card).....	3
2. USB Memory.....	3
3. Barcode Reader.....	4
3.1 Compatible Products.....	4
3.2 System equipment of barcode readers.....	5
3.2.1 System equipment (1).....	5
3.2.2 System equipment (2).....	7
3.2.3 System equipment (3).....	8
3.2.4 System equipment (4).....	9
3.2.5 System equipment (5).....	9
3.2.6 System equipment (6).....	10
3.2.7 System equipment (7).....	11
3.3 Compatible barcode types.....	12
3.4 How to read data by a barcode reader.....	13
4. 2D Code Reader.....	14
4.1 Compatible Products.....	14
4.2 System equipment of 2D code reader.....	15
4.2.1 System equipment (1).....	15
4.2.2 System equipment (2).....	17
4.2.3 System equipment (3).....	18
4.2.4 System equipment (4).....	19
4.2.5 System equipment (5).....	20

MITSUBISHI ELECTRIC CORPORATION

HEAD OFFICE : TOKYO BUILDING, 2-7-3 MARUNOUCHI, CHIYODA-KU, TOKYO 100-8310, JAPAN
NAGOYA WORKS : 1-14, YADA-MINAMI 5-CHOME, HIGASHI-KU, NAGOYA, JAPAN

4.2.6	System equipment (6).....	21
4.3	Compatible 2D code type	21
4.4	How to read data by a 2D code reader	21
5.	Hubs for Ethernet Connection and Gateway Function	22
6.	Printer.....	23
6.1	PictBridge compatible printer.....	23
6.2	Serial printer	24
7.	Video Camera	26
8.	Display.....	26
9.	Display Related Equipment: Image Transmitter and Receiver	27
10.	Speaker	27
11.	RFID Controller	27
11.1	Compatible Products	27
11.2	System equipment of RFID controllers.....	28
11.3	How to read data by an RFID controller	31
11.4	RFID Controllers Available for the External Authentication	32
12.	Modem.....	32
12.1	AT command list.....	32
12.2	Connection cable	33
12.2.1	Connection cable between a personal computer and a modem	33
12.2.2	Connection cable between a modem and the GOT.....	34
13.	USB Keyboard.....	35
14.	USB Mouse Function	35
15.	USB Hub.....	35
	REVISIONS	36

1. Memory Card (CF card and SD card)

Supported memory card	GOT				
	GT16	GT15	GT14	GT11	GT10
CF card (MITSUBISHI GT05-MEM-□C)	Not Supported *1 Max. 32GB	Supported Max. 2GB	Not Supported	Supported Max. 2GB	Not Supported
SD card (MITSUBISHI L1MEM-□GBSD)	Not Supported	Not Supported	Supported	Not Supported	Not Supported

*1 The CF card has a capacity of 32GB.

When the GOT has the BootOS with version [05.09.00.AE] or earlier and the standard monitor OS with version [05.08.99] or earlier, the USB memory has a capacity of 2GB.

For the applicable non-Mitsubishi Electric memory cards (CF cards and SD cards), refer to the following Technical Bulletins.

→ Non-Mitsubishi Electric CF card: Operation Check Results of Third Party CF Cards on GOT1000 Series Units (GOT-A-0025)

Non-Mitsubishi Electric SD card: Applicable Non-Mitsubishi SD Cards for the GT14 (HIME-T-P-0089)

2. USB Memory

A USB memory is available only for the GT16 and GT14.

Item	Specification
USB memory	USB memory compliant with USB1.1 (including forward-compatible with USB2.0 and others) *1*2

*1 For the GT16, the USB memory has a capacity of 2GB.

When the GOT has the BootOS with [05.09.00.AF] or later and the standard monitor OS with [05.09.00] or later, the maximum USB memory is 32GB.

*2 A USB memory with a particular function and others may not be available depending on the USB memory type.

Particular function examples:

- A composite device (including a hub function and a card reader function)
- A USB memory with an authentication function, an encryption function, or a security function including an anti-virus function and others
- A USB memory whose functions are added by dedicated driver software.

3. Barcode Reader

3.1 Compatible Products

Manufacturer	Model	Operation validation		Refer to
		GOT1000	GT SoftGOT1000 *3	
AIMEX Corporation	BR-530RS-B1	Supported	Not Supported	3.2.1
	BW-880RS-B1 *4	Supported	Not Supported	
IDEC AUTO-ID SOLUTIONS Corporation	DS2200-1100 *1	Supported	Not Supported	3.2.1
	DS2100-1114 *2	Supported	Not Supported	
	GRYPHON D100	Supported	Not Supported	
	GRYPHON D130	Supported	Not Supported	
	DS2400N-□□□□	Supported	Supported	3.2.6
	DS4800-1□00	Supported	Supported	
	QD2130-□□	Supported	Supported	3.2.4
	QD4130-□□	Supported	Supported	
	GBT4130-BK-BT	Supported	Supported	3.2.5
	MG1100i-1D	Supported	Supported	3.2.4
NEC Platforms, Ltd.	PD7130-YB-PTR	Supported	Supported	3.2.1
	BCH5542-STA	Supported	Not Supported	
OMRON Corporation	BCR5342H-STZ	Supported	Not Supported	3.2.2
	V520-RH21-6	Supported	Not Supported	
OPTOELECTRONICS CO.,LTD.	OPT-5125-RS232C(H)	Supported	Supported	3.2.1
	OPL-6735-RS232C(X04)	Supported	Not Supported	
	NFT-7175-RS-1	Supported	Not Supported	
	OPL-6845R-RS232	Supported	Supported	
KEYENCE CORPORATION	3.2.4			3.2.1
	BL-210R	Supported	Not Supported	
	BL-210RK *2	Supported	Not Supported	
	BL-601	Supported	Not Supported	
	BL-N70R	Supported	Not Supported	
DENSO WAVE Incorporated	SR-510	Supported	Not Supported	3.2.7
	GT10B-SB	Supported	Supported	
MARS TOHKEN SOLUTION CO.,LTD	TLMS-3500RV	Supported	Not Supported	3.2.1
	THLS-6712 *1	Supported	Not Supported	
	THLS-6800 *2	Supported	Not Supported	
Nippon Systems Development Co.,Ltd.	AC-812-000-D1	Supported	Not Supported	3.2.3
	PDC-812-400-00+PDC-812-300-D1	Supported	Supported	
Motorola Solutions, Inc.	LS2208	Supported	Not Supported	3.2.2
Honeywell International Inc.	3800G-04E	Supported	Not Supported	3.2.4

*1 GT11 is available only.

*2 GT16 or GT15 is available only. (Configure the settings in the utility of the GOT to supply 5VDC.)

*3 GT SoftGOT1000 Version 3.28E or later is required.

*4 For the GT16 and GT15, turn on the barcode reader after any of the following conditions.

- More than two seconds have elapsed since the GOT is turned on.
- The logo [GOT1000] is displayed on the screen after the GOT is turned on.

3.2 System equipment of barcode readers

The following shows the equipment to configure with different types of barcode readers.

3.2.1 System equipment (1)

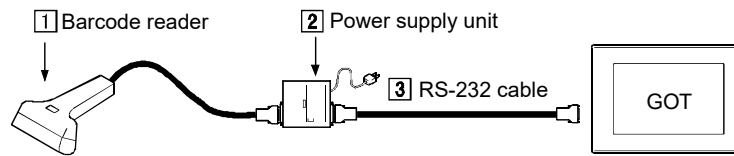

Manufacturer	1 Barcode reader	2 Power supply unit	3 RS-232 cable
AIMEX Corporation	BR-530RS-B1	Included with a barcode reader (An adapter (BB-60) must be purchased separately.)	Included with a barcode reader
	BW-880RS-B1	Included with a barcode reader	Included with a barcode reader
IDEC AUTO-ID SOLUTIONS Corporation	DS2200-1100	DSPW-2102	GT01-C30R2-25P *1
	DS2100-1114	DSPW-2102	GT01-C30R2-25P *1
	GRYPHON D100	PG5 MAIN POWER BLOCK	Included with a barcode reader
	GRYPHON D130	UL310-0515	Sold separately: CAB-327/CAB-350/CAB-362
NEC Platforms, Ltd.	BCH5542-STA	BCV5070 or CA1071	GT01-C30R2-9S *1
	BCR5342H-STZ	BCV5070 or BCA1071	GT01-C30R2-9S *1
OPTOELECTRONICS CO.,LTD.	OPT-5125-RS232C(H)	Not necessary	Included with a barcode reader *2
	OPL-6735-RS232C(X04)	DC-5300T	Included with a barcode reader
	NFT-7175-RS-1	GT16/GT15: Not necessary GT11: DC-5300T	GT16/GT15: Included with a barcode reader GT11: A cable with jack for the power supply is required.
KEYENCE CORPORATION	BL-210R	Included with a barcode reader	Included with a barcode reader
	BL-210RK	Not necessary	Produced by the user Refer to 1) below. (5VDC is required.)
	BL-601	BL-U1	Produced by the user Refer to 2) below. *3
		BL-U2	Produced by the user Refer to 3) below. *4
	BL-N70R	R3W005-025J	Included with a barcode reader
	SR-510	BL-U2	GT01-C30R2-9S
MARS TOHKEN SOLUTION CO.,LTD	TLMS-3500RV	Not necessary *5	GT01-C30R2-25P *1
	THLS-6712	AD-6712	Included with a barcode reader
	THLS-6800	An adapter must be purchased separately.	Included with a barcode reader

*1 This is a Mitsubishi Electric product. Please contact your local Mitsubishi Electric or representative for purchasing the cable.
 *2 When purchasing OPT-5125-RS232C(H), select one with the same connector shape as OPL-6735-RS232C(X04).
 *3 The OP-22149(1.5m) and the OP-25057 (conversion connector) manufactured by KEYENCE CORPORATION are available.
 *4 The OP-27937(2m) manufactured by KEYENCE CORPORATION is available.
 *5 It is necessary to supply 24VDC to the barcode reader separately. For details, please refer to the manual of the barcode reader to be used.

[Issue No.] GOT-A-0010-AC

1) Cable connection diagram for a barcode reader manufactured by KEYENCE CORPORATION (BL-210RK)
 The following shows connection cables that must be produced by the user.
 Maximum cable length: confirm with the barcode reader manufacturer.

Barcode reader		Cable connection and signal direction	GOT	
Signal name	Pin No.		Pin No.	Signal name
SG	1		1	CD
RD(RXD)	2		2	RD(RXD)
SD(TXD)	3		3	SD(TXD)
ER(DTR)	4		4	ER(DTR)
SG	5		5	SG
DR(DSR)	6		6	DR(DSR)
RS(RTS)	7		7	RS(RTS)
CS(CTS)	8		8	CS(CTS)
5V	9		9	5V

2) RS-232 cable connection diagram for a barcode reader manufactured by KEYENCE CORPORATION (BL-601, BL-U1)

The following shows connection cables that must be produced by the user.
 Maximum cable length: confirm with the barcode reader manufacturer.

Barcode reader		Cable connection and signal direction	GOT	
Signal name	Pin No.		Pin No.	Signal name
FG	1			Connector case
SD	2		2	RD(RXD)
RD	3		3	SD(TXD)
RS	4		4	ER(DTR)
CS	5		5	SG
DR	6		6	DR(DSR)
SG	7		7	RS(RTS)
	8		8	CS(CTS)
ER	20		9	-

3) Cable connection diagram for a barcode reader manufactured by KEYENCE CORPORATION (BL-601, BL-U2)
 The following shows connection cables that must be produced by the user.
 Maximum cable length: confirm with the barcode reader manufacturer.

Barcode reader		Cable connection and signal direction	GOT	
Signal name	Pin No.		Pin No.	Signal name
Connector case				Connector case
RD	2		2	RD(RXD)
SD	3		3	SD(TXD)
ER	4		4	ER(DTR)
SG	5		5	SG
DR	6		6	DR(DSR)
RS	7		7	RS(RTS)
CS	8		8	CS(CTS)
-	9		9	-

3.2.2 System equipment (2)

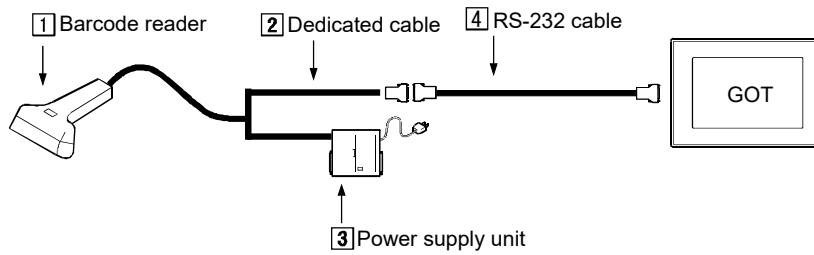

Manufacturer	1 Barcode reader	2 Dedicated cable	3 Power supply unit	4 RS-232 cable
OMRON Corporation	V520-RH21-6 (With dedicated cable)	V509-W012	S8VS-03005(A 100VAC plug cable must be purchased separately.)	Produced by the user Refer to 1) below.
Motorola Solutions, Inc.	LS2208	CBA-R01-S07PAR	symbol 50-14000-101R	Not necessary

1) Cable connection diagram for a barcode reader manufactured by OMRON Corporation

The following shows connection cables that must be produced by the user.

Maximum cable length: confirm with the barcode reader manufacturer.

Barcode reader			Cable connection and signal direction	GOT	
Signal direction	Signal name	Pin No.		Pin No.	Signal name
Internal connection	FG	1		1	CD *1
	SD(TXD) *2	2		2	RD(RXD)
	RD(RXD) *2	3		3	SD(TXD)
	RS(RTS)	4		4	ER(DTR)
	CS(CTS)	5		5	SG
	-	6		6	DR(DSR)
	-	7		7	RS(RTS)
	-	8		8	CS(CTS)
	SG	9		9	-

*1 NC for GT11

*2 A dedicated cable, V509-W012 (cross cable), is used between the barcode reader and the cables mentioned above. Even if the signal name for cable connection is SD-SD or RD-RD, the communication can be performed with no problem.

3.2.3 System equipment (3)

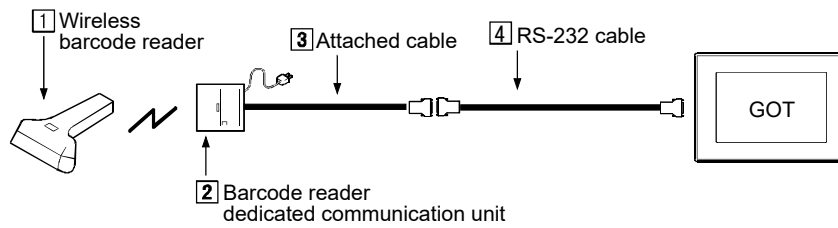

Manufacturer	1 Wireless barcode reader	2 Barcode reader dedicated communication unit	3 Attached cable	4 RS-232 cable	
Nippon Systems Development Co.,Ltd.	AC-812-000-D1	Included with a barcode reader	Included with a barcode reader	GT16	Not required with the extended function OS, Barcode [04.00.**] or later
	PDC-812-400-00 + PDC-812-300-D1			GT15	Not required with the extended function OS, Barcode [03.00.00] or later Produced by the user with the extended function OS, Barcode [02.04.**] or earlier Refer to 1) below.
				GT11	Not required By using 3 Attached cable, a barcode reader can be connected to the GOT.

1) RS-232 cable connection diagram for a barcode reader manufactured by Nippon Systems Development Co., Ltd.

The following shows connection cables that must be produced by the user.
Maximum cable length: confirm with the barcode reader manufacturer.

Barcode reader		Cable connection and signal direction	GOT	
Signal name	Pin No.		Pin No.	Signal name
-	1		1	CD
SD(TXD)	2		2	RD(RXD)
RD(RXD)	3		3	SD(TXD)
-	4		4	ER(DTR)
SG	5		5	SG
DTR(ER)	6		6	DR(DSR)
CS(CTS)	7		7	RS(RTS)
RS(RTS)	8		8	CS(CTS)
SG	9		9	-

3.2.4 System equipment (4)

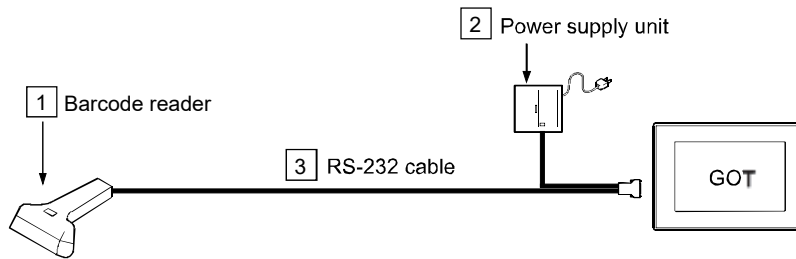

Manufacturer	1 Barcode reader	2 Power supply unit	3 RS-232 cable
IDEC AUTO-ID SOLUTIONS Corporation	QD2130-□□	UL310-0515	CAB-350 *1
	QD4130-□□		
	MG1100i-1D	HK-CP13-A05	8-0736-80 *1
	PD7130-YB-PTR	SET8-0935	CAB-433 *1
OPTOELECTRONICS CO.,LTD.	OPL-6845R-RS232	Included with a barcode reader	Included with a barcode reader *1
Honeywell International Inc	3800G-04E	An adapter must be purchased separately.	Included with a barcode reader

*1 To connect the barcode reader to GT SoftGOT1000, connect the following USB/RS-232 conversion cables to a USB port on the personal computer.

For the USB/RS-232 conversion cables, refer to Technical Bulletin FA-D-0036.

- DIFC-U2 (Diatrend Corporation)
- DAC01R2VD (Diatrend Corporation)

<Connection example>

[Barcode reader (RS-232)] + [3] RS-232 cable + [DAC01R2VD] + [DIFC-U2] + [Personal computer (USB)]

3.2.5 System equipment (5)

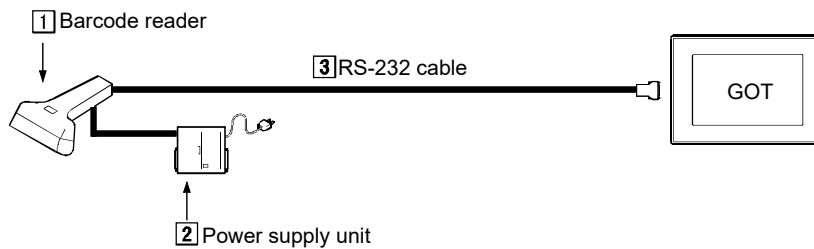

Manufacturer	1 Barcode reader	2 Power supply unit	3 RS-232 cable
IDEC AUTO-ID SOLUTIONS Corporation	GBT4130-BK-BT	PSAA18U-120	CAB-350 *1

*1 To connect the barcode reader to GT SoftGOT1000, connect the following USB/RS-232 conversion cables to a USB port on the personal computer.

For the USB/RS-232 conversion cables, refer to Technical Bulletin FA-D-0036.

- DIFC-U2 (Diatrend Corporation)
- DAC01R2VD (Diatrend Corporation)

<Connection example>

[Barcode reader (RS-232)] + [3] RS-232 cable + [DAC01R2VD] + [DIFC-U2] + [Personal computer (USB)]

3.2.6 System equipment (6)

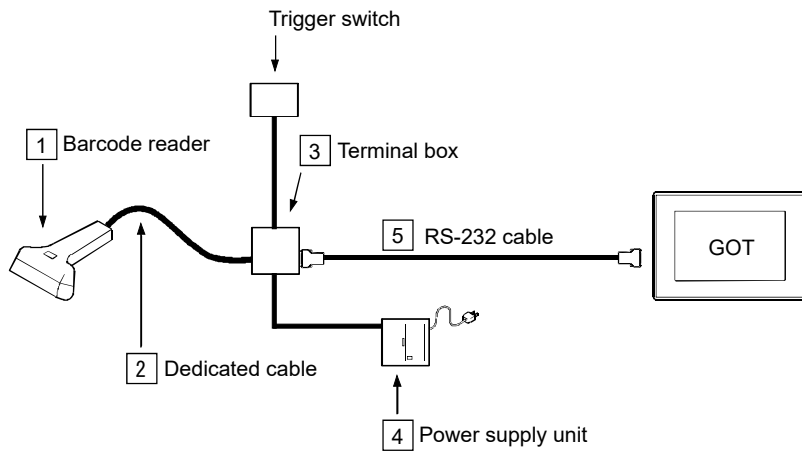

Manufacturer	1 Barcode reader	2 Dedicated cable	3 Terminal box	4 Power supply unit	5 RS-232 cable
IDECA AUTO-ID SOLUTIONS Corporation	DS2400N-□□□□ DS4800-1□00	Included with a barcode reader	CBX100	PS5R-B24	Produced by the user Refer to 1) below.

1) RS-232 cable connection diagram for a barcode reader manufactured by IDECA AUTO-ID SOLUTIONS Corporation.

The following shows connection cables that must be produced by the user.

Maximum cable length: confirm with the barcode reader manufacturer.

Barcode reader		Cable connection and signal direction	GOT	
Signal name	Pin No.		Pin No.	Signal name
SGND	-	←	1	CD
TX	-	→	2	RD(RXD)
RTS	-	→	3	SD(TXD)
RX	-	←	4	ER(DTR)
CTS	-	→	5	SG
-	-		6	DR(DSR)
-	-		7	RS(RTS)
-	-		8	CS(CTS)
-	-		9	NC

3.2.7 System equipment (7)

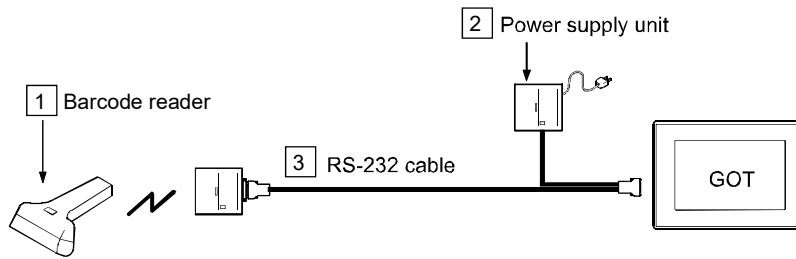

Manufacturer	1 Barcode reader	2 Power supply unit	3 RS-232 cable
DENSO WAVE INCORPORATED	GT10B-SB	Included with a barcode reader (A Bluetooth adapter (BA-10RKU) must be purchased separately.)	CBBA-RS2000/9 *1

*1 To connect the barcode reader to GT SoftGOT1000, connect the following USB/RS-232 conversion cables to a USB port on the personal computer.

For the USB/RS-232 conversion cables, refer to Technical Bulletin FA-D-0036.

- DIFC-U2 (Diatrend Corporation)
- DAC01R2VD (Diatrend Corporation)

<Connection example>

[Barcode reader (RS-232)] + [3 RS-232 cable] + [DAC01R2VD] + [DIFC-U2] + [Personal computer (USB)]

3.3 Compatible barcode types

The following barcode reader communication settings are supported by the GOT.

○: Can be read in the GOT, △: Partly restricted, ×: Unreadable in GOT

Manufacturer	Barcode reader	Barcode type									
		UPC) WPC (JAN, EAN,	CODE-39	CODE-93	CODE-128	NW-7 (CODABAR)	Zof5 (Industrial)	ITF (2of5Interleaved)	MSI/Plessey	IATA Zof5	
AIMEX Corporation	BR-530RS-B1	○	○	○	○	○	○	×	○	×	×
	BW-880RS-B1	○	○	○	○	○	○	○	○	○	×
IDEC AUTO-ID SOLUTIONS Corporation	DS2200-1100	○	○	○	○	○	○	×	○	×	×
	DS2100-1114	○	○	○	○	○	○	×	○	×	×
	GRYPHON D100	○	○	○	○	○	○	○	○	○	×
	GRYPHON D130	○	○	○	○	○	○	○	○	×	×
	DS2400N-□□□□	○	○	○	○	○	○	○	○	○	○
	DS4800-1□00	○	○	○	○	○	○	○	○	○	○
	QD2130-□□	○	○	○	○	○	○	○	○	○	○
	DQ4130-□□	○	○	○	○	○	○	○	○	○	○
	GBT4130-BK-BT	○	○	○	○	○	○	○	○	○	○
	MG1100i-1D	○	○	○	○	○	○	○	○	○	○
PD7130-YB-PTR	○	○	○	○	○	○	○	○	○	○	
NEC Platforms, Ltd.	BCH5542-STA	○	○	○	○	○	○	○	○	×	×
	BCR5342H-STZ	○	○	○	○	○	○	○	○	×	×
OMRON Corporation	V520-RH21-6	○	○	○	○	○	○	×	○	×	×
OPTOELECTRONICS CO.,LTD.	OPT-5125-RS232C(H)	○	○	○	○	○	○	○	○	○	×
	OPL-6735-RS232C(X04)	○	○	○	○	○	○	○	○	○	×
	NFT-7175-RS-1	○	○	○	○	○	○	○	×	○	×
	OPL-6845R-RS232	○	○	○	○	○	○	○	×	×	○
KEYENCE CORPORATION	BL-210R	○	○	○	○	○	○	○	○	×	×
	BL-210RK	○	○	○	○	○	○	×	×	×	×
	BL-601	○	○	○	○	○	○	○	○	×	×
	BL-N70R	○	○	○	○	○	○	×	○	○	×
	SR-510	○	○	○	○	○	○	○	○	×	×
	HR-50R	○	○	○	○	○	○	○	○	×	×
DENSO WAVE INCORPORATED	GT10B-SB	○	○	○	○	○	○	○	○	○	×
MARS TOHKEN SOLUTION CO.LTD.	TLMS-3500RV	△*1	○	×	○	○	○	×	○	×	×
	THLS-6712	○	○	○	○	○	○	×	○	×	×
	THLS-6800	○	○	○	○	○	○	×	○	×	×
Nippon Systems Development Co.,Ltd.	AC-812-000-D1	○	○	×	○	○	○	○	○	×	×
Motorola Solutions, Inc.	LS2208	○	○	○	○	○	○	×	○	×	×
Honeywell International Inc.	3800G-04E	○	○	○	○	○	○	×	○	×	○

*1 Only JAN is supported.

3.4 How to read data by a barcode reader

Please refer to the followings for the data transfer format (header/terminator settings and others) that can be used in the GOT or the setting method to read data by a barcode reader.

- (a) Data transfer format (header/terminator settings and others) that can be used in the GOT.
- (b) Setting to connect a barcode reader to the GOT. ([Peripheral Setting] on GT Designer3 or [Communication Settings] on GT Designer2)
- (c) Setting to write the data, read by a barcode reader, to the PLC CPU. ([Detail Setting] in the [Bar Code] dialog box on GT Designer3 or [Detail Setting] in the [Bar Code] dialog box on GT Designer2)

Refer to the following.

- GT Designer3 Version□ Screen Design Manual (Functions) (SH-080867ENG)
- GT Designer2 Version□ Screen Design Manual (SH-080530ENG)

- (d) Setting procedure from connecting a barcode reader to the GOT until reading a barcode.

Refer to the following.

- GOT1000 Series Connection Manual (Microcomputer, MODBUS Products, Peripherals) for GT Works3 (SH-080871ENG)
- GOT1000 Series Connection Manual (SH-080532ENG)

4. 2D Code Reader

4.1 Compatible Products

Manufacturer	Model	Operation validation		Reference
		GOT1000	GT SoftGOT1000 *4	
AIMEX Corporation	IT4600SR-RS	Supported	Not Supported	4.2.1
IDEC AUTO-ID SOLUTIONS Corporation	MATRIX210-21□-□□□	Supported	Supported	4.2.4
	MATRIX410-□□□-0□0	Supported	Supported	4.2.3
	GD4430-□□	Supported	Supported	
	GD4430-□□-HD	Supported	Supported	
	GBT4430-□□	Supported	Supported	
	MG1100i-2D	Supported	Supported	
	M3200i Series	Supported	Supported	
OMRON Corporation	V400-F250	Supported	Not Supported	4.2.1
OPTOELECTRONICS CO.,LTD.	OPD-7435	Supported	Not Supported	4.2.1
	NFD1267 *1	Supported	Not Supported	4.2.1
	OPI-3601-V	Supported	Supported	
KEYENCE CORPORATION	TL-30	Supported	Supported	4.2.1
	TL-40	Supported	Not Supported	
	SR-510	Supported	Not Supported	
	HR-100	Supported	Supported	
DENSO WAVE INCORPORATED	GT10Q-SB	Supported	Not Supported	4.2.1
	GT10Q-SR	Supported	Supported	
	GT11Q-SR	Supported	Supported	
	QB20/20-HD *2	Supported	Not Supported	
	QB20K *1	Supported	Not Supported	
	QD20	Supported	Not Supported	
	AT10Q-SM	Supported	Not Supported	4.2.3
MARS TOHKEN SOLUTION CO.LTD.	THIR-3000N	Supported	Supported	4.2.1
	TFIR-3102 *2	Supported	Not Supported	
	THIR-6000	Supported	Not Supported	
	TFIR-31	Supported	Not Supported	
	THIR-6200DDM	Supported	Not Supported	
Cognex K.K.	THIR-6780R	Supported	Supported	4.2.1
	DataMan 100	Supported	Not Supported	
	DataMan 7500/7500LR	Supported	Not Supported	
	DataMan 7550/7550LR	Supported	Not Supported	
	DataMan 750/750S	Supported	Not Supported	
	DataMan 200 *3	Supported	Not Supported	
Motorola Solutions, Inc.	DS6608-RS-DOS/V	Supported	Supported	4.2.1
Honeywell International Inc.	1900GSR-2	Supported	Supported	4.2.3

*1 GT16 or GT15 is available only. (5VDC is required.)

*2 GT11 is available only.

*3 Configure the communication settings of the DataMan 200 and the GOT as shown below.

Setting item	Set value
Baud rate	115200 bps
Data length	8 bits or 7 bits
Stop bit	None, Even number or odd number
Parity	1 bit or 2 bits

*4 GT SoftGOT1000 Version 3.28E or later is required.

4.2 System equipment of 2D code reader

The following shows the equipment to configure with different types of 2D code readers.

4.2.1 System equipment (1)

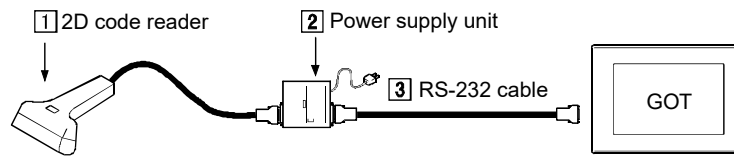

Manufacturer	1 2D code reader	2 Power supply unit	3 RS-232 cable
AIMEX Corporation	IT4600SR-RS	Included with a 2D code reader	Included with a 2D code reader
OMRON Corporation	V400-F250	Not necessary *1*2	Purchased by the user (V400-W24) Including a 24VDC power cable
OPTOELECTRONICS CO.,LTD.	OPD-7435	Included with a 2D code reader	Included with a 2D code reader
	NFD1267	Not necessary *3	Produced by the user Refer to 1) below. (5VDC is required.)
	OPI-3601-V	Included with a 2D code reader	Included with a 2D code reader
KEYENCE CORPORATION	TL-30	TL-U1	For GT11, included with a 2D code reader For GT16 or GT15, refer to 2) below.
	TL-40	TL-U1	Included with a 2D code reader
	SR-510	BL-U2	GT01-C30R2-9S *4
	HR-100	OP-87530	HR-1C3RC
DENSO WAVE INCORPORATED	GT10Q-SR	AD1005/3600	GT27, GT25, GT21: ·CBG1-RS2000/9 ·CBG1-RS5000/9-1 ·GT10Q RS232C/2m Curl SoftGOT2000: *5
	GT11Q-SR	AD1005/3600	CBG11-RS2000/9
	QB20/20-HD	2000639	496800-0040
	QB20K	Included with a 2D code reader	Included with a 2D code reader
	QD20	Not necessary *1*2	Produced by the user Refer to 3) below.
	MARS TOHKEN SOLUTION CO.LTD.	THIR-3000N	S-8440
TFIR-3102		Not necessary *1	Produced by the user Refer to 4) below.
THIR-6000		Included with a 2D code reader	Included with a 2D code reader
TFIR-31		Included with a 2D code reader	Included with a 2D code reader
THIR-6200DDM		Included with a 2D code reader	Included with a 2D code reader
THIR-6780R		Included with a 2D code reader	Included with a 2D code reader
Cognex K.K.	DataMan 100	DM100-RWR-000	DM100-RS232-000
	DataMan 7500	Included with a 2D code reader	DM42206139-04
	DataMan 7550	Included with a 2D code reader	DM42203758-03S
Motorola Solutions, Inc.	DS6608-RS-DOS/V	Included with a 2D code reader	Included with a 2D code reader *5

*1 It is necessary to supply 24VDC to the 2D code reader separately. For details, please refer to the manual of the 2D code reader to be used.

*2 For adjusting settings of the 2D code reader by using the monitor, please refer to the manual of the 2D code reader to be used.

*3 It is necessary to supply 5VDC to the 2D code reader separately. For details, please refer to the manual of the 2D code reader to be used.

*4 This is a Mitsubishi Electric product. Please contact your local Mitsubishi Electric or representative for purchasing the cable.

*5 To connect the 2D code reader to GT SoftGOT1000, connect the following USB/RS-232 conversion cables to a USB port on the personal computer.

For the USB/RS-232 conversion cables, refer to Technical Bulletin FA-D-0036.

- DIFC-U2 (Diatrend Corporation)

- DAC01R2VD (Diatrend Corporation)

<Connection example>

[2D code reader (RS-232)] + [3 RS-232 cable] + [DAC01R2VD] + [DIFC-U2] + [Personal computer (USB)]

*6 With the USB/RS-232 conversion cables (DIFC-U2 and DAC01R2VD), configure the 2D code reader setting so that the RS/CS control is not performed.

[Issue No.] GOT-A-0010-AC

1) RS-232 cable connection diagram for a 2D code reader manufactured by OPTOELECTRONICS CO., LTD.
The following shows connection cables that must be produced by the user.
Maximum cable length: confirm with the 2D code reader manufacturer.

2D code reader		Cable connection and signal direction	GOT	
Signal name	Pin No.		Pin No.	Signal name
Trigger	Green		1	CD
OK-	Yellow		2	RD(RXD)
NG	Blue		3	SD(TXD)
SD	Purple		4	DTR(ER)
RD	Orange		5	SG
RS	Brown		6	DSR(DR)
CS	Gray		7	RS(RTS)
+5V	Red		8	CS(CTS)
GND	White		9	5V

2) RS-232 cable connection diagram for a 2D code reader manufactured by KEYENCE CORPORATION
The following shows connection cables that must be produced by the user.
Maximum cable length: confirm with the 2D code reader manufacturer.

2D code reader		Cable connection and signal direction	GOT	
Signal name	Pin No.		Pin No.	Signal name
N.C	1		1	CD
SD(TXD)	2		2	RD(RXD)
RD(RXD)	3		3	SD(TXD)
N.C	4		4	DTR(ER)
SG	5		5	SG
N.C	6		6	DSR(DR)
CS(CTS)	7		7	RS(RTS)
RS(RTS)	8		8	CS(CTS)
N.C	9		9	-

3) RS-232 cable connection diagram for a 2D code reader manufactured by DENSO WAVE INCORPORATED
The following shows connection cables that must be produced by the user.
Maximum cable length: confirm with the 2D code reader manufacturer.

2D code reader		Cable connection and signal direction	GOT	
Signal name	Pin No.		Pin No.	Signal name
-	-		1	CD
/TXD	2		2	RD(RXD)
/RXD	3		3	SD(TXD)
-	-		4	DTR(ER)
GND	5		5	SG
-	-		6	DSR(DR)
CTS	7		7	RS(RTS)
RTS	8		8	CS(CTS)
-	-		9	NC

[Issue No.] GOT-A-0010-AC

4) RS-232 cable connection diagram for a 2D code reader manufactured by MARS TOHKEN SOLUTION CO.LTD.

The following shows connection cables that must be produced by the user.

Maximum cable length: confirm with the 2D code reader manufacturer.

2D code reader		Cable connection and signal direction	GOT	
Signal name	Pin No.		Pin No.	Signal name
-	-		1	CD *1
RXD /RD-	2		2	RD(RXD)
TXD /TD+	3		3	SD(TXD)
-	-		4	DTR(ER)
GND	5		5	SG
-	-		6	DSR(DR)
-	-		7	RS(RTS)
RTS	11		8	CS(CTS)
CTS	12		9	-

*1 NC for GT11

4.2.2 System equipment (2)

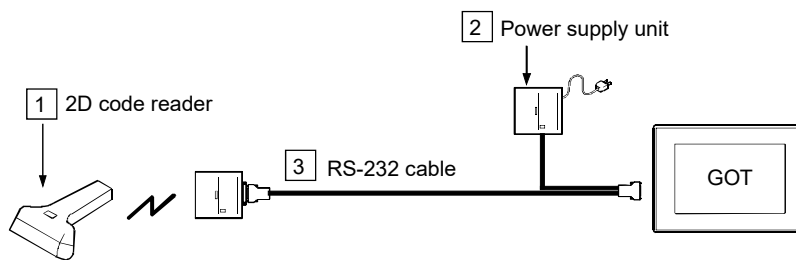

Manufacturer	1 2D code reader	2 Power supply unit	3 RS-232 cable
DENSO WAVE INCORPORATED	GT10Q-SB	Included with a 2D code reader (A Bluetooth adapter (BA10-RKU) must be purchased separately.)	CBBA-RS2000/9

4.2.3 System equipment (3)

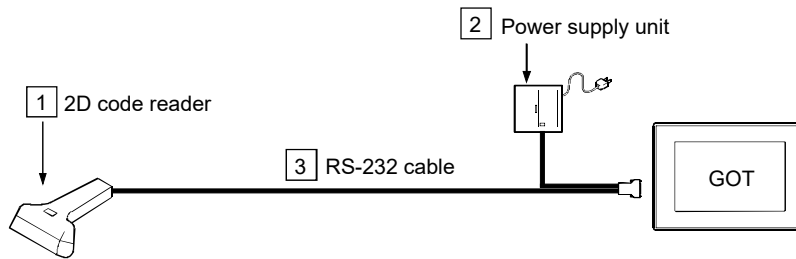

Manufacturer	1 2D code reader	2 Power supply unit	3 RS-232 cable
IDEC AUTO-ID SOLUTIONS Corporation	GD4430-□□	UL310-0515 , or 5V power supply from the GOT standard interface *2	CAB-350 *3
	GD4430-□□-HD		
	GBT4430-□□		
	MG1100i-2D	11-0387 or HK-CP13-A05	
DENSO WAVE INCORPORATED	M3200i Series	Included with a 2D code reader	8-0730-54 *3
	AT10Q-SM	Included with a 2D code reader	Included with a 2D code reader
	Cognex K.K.	DataMan 750	DMA-24KIT-00, DM100-PWR-000
DataMan 750S			
DataMan 8100 *1		DM100-PWR-00	DM8000-RS232-00
DataMan 8500 *1			
Honeywell International Inc.	1900GSR-2	Included with a 2D code reader	Included with a 2D code reader

*1 DataMan 8100/8500 requires the communication module DMCM-SERIALM-00.

*2 It is necessary to supply 5VDC to the 2D code reader separately. For details, please refer to the manual of the 2D code reader to be used.

*3 To connect the 2D code reader to GT SoftGOT2000, connect the following USB/RS-232 conversion cables to a USB port on the personal computer.

For the USB/RS-232 conversion cables, refer to Technical Bulletin FA-D-0036.

- DIFC-U2 (Diatrend Corporation)
- DAC01R2VD (Diatrend Corporation)

<Connection example>

[2D code reader (RS-232)] + [3 RS-232 cable] + [DAC01R2VD] + [DIFC-U2] + [Personal computer (USB)]

4.2.4 System equipment (4)

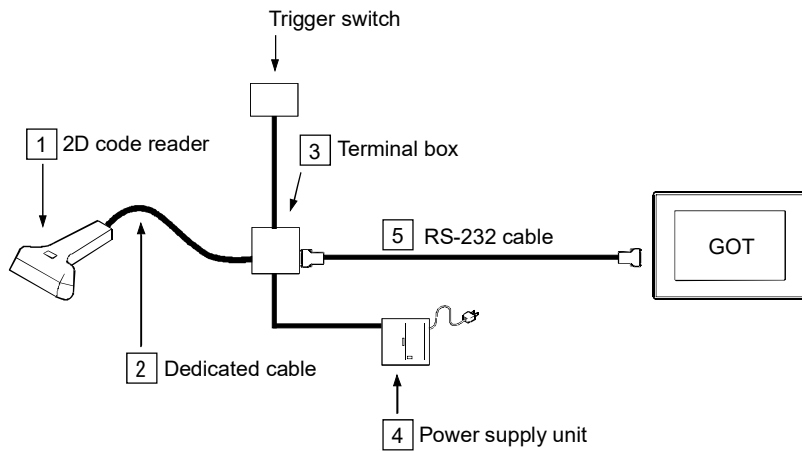

Manufacturer	1 2D code reader	2 Dedicated cable	3 Terminal box	4 Power supply unit	5 RS-232 cable
IDEC AUTO-ID SOLUTIONS Corporation	MATRIX210-21□-□□□	Included with a 2D code reader	CBX100	PS5R-B24	Produced by the user Refer to 1) below.
	MATRIX410-□□□-0□0	CAB-MS01			

1) RS-232 cable connection diagram for a 2D code reader manufactured by IDEC AUTO-ID SOLUTIONS Corporation.

The following shows connection cables that must be produced by the user. Maximum cable length: confirm with the barcode reader manufacturer.

Barcode reader		Cable connection and signal direction	GOT	
Signal name	Pin No.		Pin No.	Signal name
SGND	-	←	1	CD
TX	-	→	2	RD(RXD)
RTS	-	→	3	SD(TXD)
RX	-	←	4	ER(DTR)
CTS	-	→	5	SG
-	-		6	DR(DSR)
-	-		7	RS(RTS)
-	-		8	CTS
-	-		9	NC

4.2.5 System equipment (5)

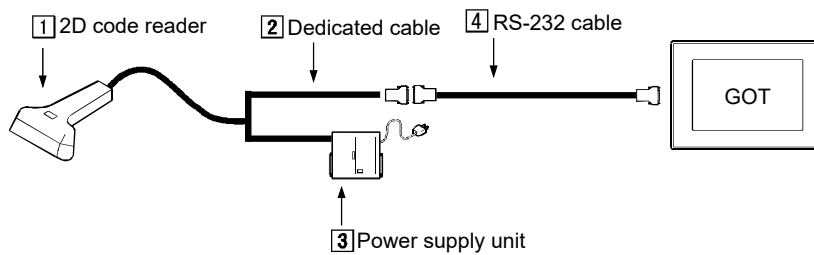

Manufacturer	1 2D code reader	2 Dedicated cable	3 Power supply unit	4 RS-232 cable	
KEYENCE CORPORATION	TL-30	Included with a 2D code reader	TL-U1	GT16	Not required with the extended function OS, Barcode [04.00.**] or later
				GT15	Not required with the extended function OS, Barcode [03.00.00] or later Produced by the user with the extended function OS, Barcode [02.04.**] or earlier Refer to 1) below.
				GT11	Not required By using 2 Dedicated cable, a 2D code reader can be connected to the GOT.

1) RS-232 cable connection diagram for a 2D code reader manufactured by KEYENCE CORPORATION. The following shows connection cables that must be produced by the user. Maximum cable length: confirm with the barcode reader manufacturer.

2D code reader		Cable connection and signal direction	GOT	
Signal name	Pin No.		Pin No.	Signal name
N.C	1		1	CD
SD(TXD)	2	→	2	RD(RXD)
RD(RXD)	3	←	3	SD(TXD)
N.C	4		4	DTR(ER)
SG	5	←	5	SG
N.C	6		6	DSR(DR)
CS(CTS)	7	←	7	RS(RTS)
RS(RTS)	8	→	8	CS(CTS)
N.C	9		9	NC

4.2.6 System equipment (6)

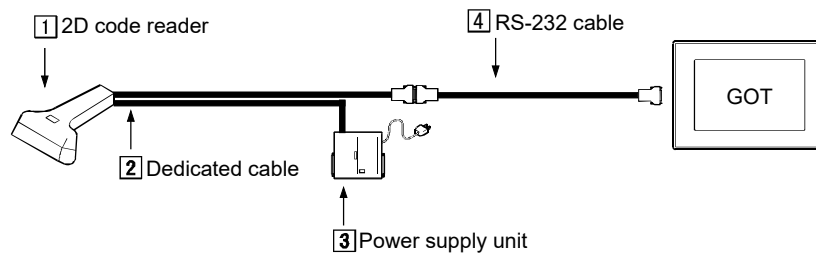

Manufacturer	1 2D code reader	2 Dedicated cable	3 Power supply unit	4 RS-232 cable
Cognex K.K.	DataMan 200	CCB-84901-1003-△△	CPS-AC-POE1A-△△	CCB-M8X4-△△

4.3 Compatible 2D code type

Only “QR code” is supported by the GOT.

4.4 How to read data by a 2D code reader

Please refer to the followings for the data transfer format (header/terminator settings and others) that can be used in the GOT or the setting method to read data by a 2D code reader.

- (a) Data transfer format (header/terminator settings and others) that can be used in the GOT.
- (b) Setting to connect a 2D code reader to the GOT. ([Peripheral Setting] on GT Designer3 or [Communication Settings] on GT Designer2)
- (c) Setting to write the data, read by a 2D code reader, to the PLC CPU. ([Detail Setting] in the [Bar Code] dialog box on GT Designer3 or [Detail Setting] in the [Bar Code] dialog box on GT Designer2)
Refer to the following.
 - GT Designer3 Version□ Screen Design Manual (Fundamentals) (SH-080866ENG)
 - GT Designer2 Version□ Screen Design Manual (SH-080530ENG)
- (d) Setting the procedure from connecting a 2D code reader to the GOT until reading 2D code data.
Refer to the following.
 - GOT1000 Series Connection Manual (Microcomputer, MODBUS Products, Peripherals) for GT Works3 (SH-080871ENG)
 - GOT1000 Series Connection Manual (SH-080532ENG)

[Issue No.] GOT-A-0010-AC

5. Hubs for Ethernet Connection and Gateway Function

(Compatible Product)

Manufacturer	Model
Allied Telesis K.K.	CentreCOM FS708XL, CentreCOM MR815TL, CentreCOM RH505EL, CentreCOM FS705TX, CentreCOM FS705TX V2
I-O DATA DEVICE, INC.	ETX-ESH5, ETX-SH5
KEYENCE CORPORATION	NE-V08
PHOENIX CONTACT	FL SWITCH SF 8TX, FL SWITCH 5TX (Hardware version 13 or later)
Mitsubishi Electric Corporation	NZ2EHG-T8
Mitsubishi Cable Industries, Ltd.	ET10618, ST12904-AC

(Discontinued Product *1)

Manufacturer	Model
Allied Telesis K.K.	CentreCOM MR820TR, CentreCOM 3012TR V2
Mitsubishi Cable Industries, Ltd.	ST12608

*1 Discontinued Products are not checked with GOT2000 Series.

(Incompatible Product *1)

Manufacturer	Model
BUFFALO INC.	LSW-TX-5EP

*1 Incompatible Products are not checked with GOT2000 Series.

6. Printer

The following printers can be used with the GOT2000 series.

GOT	Available printer	Available software	Reference
GT16	PictBridge compatible printer	GT Designer2/GT Works2 Version2.27D or later GT Works3 Version1.01B or later	6.1
	Serial printer	GT Works3 Version1.17T or later	6.2
GT15	PictBridge compatible printer	GT Designer2/GT Works2 Version2.27D or later GT Works3 Version1.01B or later	6.1
	Serial printer	GT Works3 Version1.17T or later	6.2
GT14	Serial printer	GT Works3 Version1.54G or later	6.2
GT11	-	-	-
GT10	Serial printer	GT Works3 Version1.54G or later	6.2

6.1 PictBridge compatible printer

By mounting the printer unit (GT15-PRN) on the GT16 or the GT15, a PictBridge compatible printer is available. For the GT15-PRN printer unit, only PictBridge compatible printers are connectable. (Serial printers cannot be connected.)

To use a PictBridge compatible printer, install the extended function OS (Printer (PictBridge)) to the GOT with the following screen design software.

- **GT Designer2/GT Works2 Version 2.27D** or later
- **GT Works3 Version 1.01B** or later

Precautions

PictBridge compatible printers are available, however the paper size, print area, or corrective actions for errors vary according to the type of the model. For details, follow the printer manual.

(1) Paper size

Regardless of the paper size set on the GOT, an image on the GOT may be printed at the size set on the printer. When the paper size of the hard copy is specified other than the A4 size, an error may occur and the hard copy cannot be printed. Set the paper size to A4.

(2) Printable area

When using the report function of the GOT, the printable area varies according to the printer.

By the printer specifications, the trimming process is performed and some specified lines may not be printed. (The trimming process adjusts image dimensions to a full printable area specified for the paper size, and does not print the unprintable areas.)

When some areas are not printed, adjust margins and lines by using the report function of the GOT in accordance with the printer specifications. (Refer to the figure below.)

Example) When the number of lines is set to 70, and the first line and 70th line are unprintable

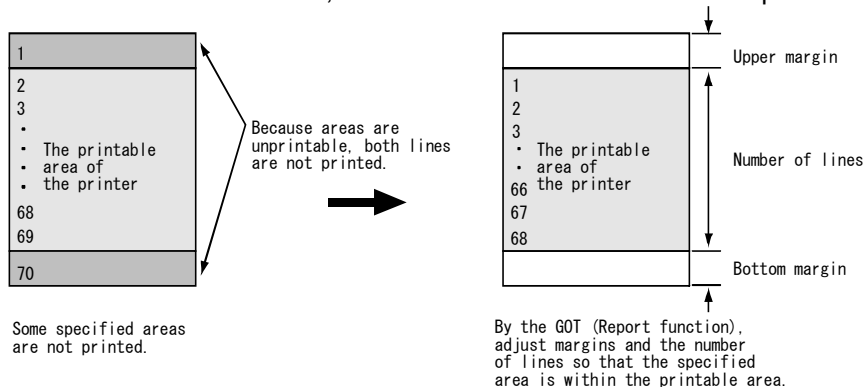

When some of lines are not printed for the report function of the GOT, configure the printer setting with no trimming. Doing so may print the lines correctly.

[Issue No.] GOT-A-0010-AC

(3) Paper jam

For the paper jam, remove the paper, and then execute the printing process again by using the GOT.

When the printing process does not start after the above actions, execute any of the following methods.

- (a) Press the cancel button on the printer to stop the printing process, and then execute the printing process again by using the GOT.
- (b) Disconnect and connect the cable of the printer, and then turn on the printer again. (The printing process starts again automatically.)
- (c) Press the OK button on the printer to stop the printing process. Then execute the printing process again by using the GOT.
- (d) Press the cancel button on the printer. (The printing process starts again automatically.)

(4) Others

For some printers, the print enable/disable status notification signal (GS258.b3) may turn on before the preparations for printing are not completed.

Check the preparations for printing and then execute the printing process.

6.2 Serial printer

You can use a serial printer by connecting to the built-in RS-232 interface of the GT16, GT15, GT14, or GT10, or by mounting the GT15-RS2-9P on the GT16 or GT15.

To use a serial printer, install the extended function OS (Printer (serial)) to the GOT with the following screen design software.

- **GT Works3 Version 1.17T** or later for the GT16 and GT15

- **GT Works3 Version 1.54G** or later for the G14

For the GT10, install the standard monitor OS to the GOT with **GT Works3 Version 1.54G** or later.

The GOTs support printer control code ESC/P24-J84.

(Compatible Product)

Manufacturer	Model	Available hard copy size	Reference
NADA ELECTRONICS, LTD.	TP-642EG *2	QVGA, VGA *1	Refer to (1) below.
	TP-1728G *2	QVGA, VGA, SVGA, XGA	
SEIKO EPSON CORPORATION	VP-700U	QVGA, VGA, SVGA	Refer to (2) below.

*1 Since the hard copy size is larger than the printable size, set the printer setting to Group 6 (unprintable area not printed) or Group 5 (the hard copy printed in a reduced size).

For details on the groups of the printer setting, refer to the manual of the printer.

*2 TP-642EG or TP-1728G only supports the hard copy function.

[Issue No.] GOT-A-0010-AC

(1) Cable connection diagram and precautions for a printer manufactured by NADA ELECTRONICS, LTD.

(a) Connection cable diagram

The following shows connection cables that must be produced by the user.
(Maximum cable length: confirm with a printer manufacturer.)

Printer		Cable connection and signal direction	GOT	
Signal name	Pin No.		Pin No.	Signal name
-	-		1	CD
RXD	2		2	RD(RXD)
TXD	3		3	SD(TXD)
-	-		4	DTR(ER)
GND	5		5	SG
-	-		6	DSR(DR)
RTS	7		7	RS(RTS)
CTS	8		8	CS(CTS)
-	-		9	NC

(b) Precautions

- Monochrome printing
- If printing is interrupted due to a turned-off printer, cable disconnection, and others, turn off and then on the printer power, and perform the printing again.
- For printing with the report function, one-byte characters are printed as two-byte characters.
- For printing with the report function, the left margin setting of the print format is disabled.
- Since the printing paper is roll paper, the page break function is disabled.

(2) Cable connection diagram and precautions for a printer manufactured by SEIKO EPSON CORPORATION

(a) Connection cable diagram

The following shows connection cables that must be produced by the user.
(Maximum cable length: confirm with a printer manufacturer.)

Printer		Cable connection and signal direction	GOT	
Signal name	Pin No.		Pin No.	Signal name
-	-		1	CD
TXD	2		2	RD(RXD)
RXD	3		3	SD(TXD)
-	-		4	DTR(ER)
SIGNAL GND	7		5	SG
-	-		6	DSR(DR)
-	-		7	RS(RTS)
DTR	20		8	CS(CTS)
-	-		9	NC

(b) Precautions

- Monochrome printing
- If printing is interrupted due to a turned-off printer, cable disconnection, and others, turn off and then on the printer power, and perform the printing again.
- For printing with the report function, the available left margin setting of the print format ranges from 0 to 67.

[Issue No.] GOT-A-0010-AC

7. Video Camera

Precautions

Some video cameras may require a separate power supply unit.
Regarding a required power supply unit for a video camera, confirm with the manufacturer.

(Compatible Product)

Manufacturer	Model
Sony Corporation	XC-ST70 *1, XC-ST50 *1, XC-ST51 *1, XC-ES50 *1, XC-ES50L *1, XC-ES51 *1, XC-ES30 *1, XC-EI50 *1, XC-EI30 *1, XC-ST70CE *2, XC-ST30CE *2, XC-ES30CE *2
TOSHIBA TELI CORPORATION	CS8630i *1, CS8550i-51 *1*4, CS8311Bi *2, CS8310Bi *1
Mitsubishi Electric Corporation	CIT-8000 *3*5, CIT-8510M *3*5, CIT-8800M *3*5, CIT-9510M *3*5, C-4010 *3*5, C-2600 *3*5, C-2670 *3*5, C-2915 *3*5

- *1 EIA format (Monochrome) Set NTSC for the video input signal of the communication settings.
- *2 CCIR format (Monochrome) Set PAL for the video input signal of the communication settings.
- *3 NTSC format (Color)
- *4 Set the 1/60s interlace mode for the video output mode (VIDEO) of the dipswitch on the camera rear panel.
- *5 Some video cameras may require a separate power supply unit or the equipment for converting the specifications to Mitsubishi specifications. For details, check the manual of the video camera to be used.

(Discontinued Product *3)

Manufacturer	Model
TOSHIBA TELI CORPORATION	CS5260BD *2*3*4*6, CS5270B *2, CS8420i *1, CS8430i *1
Mitsubishi Electric Corporation	CIT-722 *2*5*6, CIT-743 *2*5, CIT-772 *2*5, CIT-7300 *2*5, CIT-7500 *2*5*6, CIT-7550 *2*5, CIT-8510 *2*5*6, CIT-8800 *2*5*6, CIT-9510 *2*5*6, C-2860 *2*5, C-2910 *2*5

- *1 EIA format (Monochrome) Set NTSC for the video input signal of the communication settings.
- *2 NTSC format (Color)
- *3 PAL format (Color)
- *4 The type of the model is different from NTSC format and PAL format.
- *5 Some video cameras may require a separate power supply unit or the equipment for converting the specifications to Mitsubishi specifications. For details, check the manual of the video camera to be used.
- *6 Discontinued Products are not checked with GT16.

8. Display

(Compatible Product)

Manufacturer	Model
Mitsubishi Electric Corporation	RDT242WH, RDT241WEX, RDT234WX

(Discontinued Product)

Manufacturer	Model
Dell Inc.	2007FP
BUFFALO INC.	FTD-G722AS/F *1
Mitsubishi Electric Corporation	RDT261WH, RDT241W, RDT222WM, RDT221WLM, RDT203WM, RDT201WLM, RDT193WM, RDT191WLM, RDT195LM, RDT194LM, RDT179LM, RDT178LM, RDT177LM, RDT1714VM, RDT158LM, RDT196S *1, RDT196V *1, RDT1712S *1, RDT1712V *1, RDT176LM *1, RDT1713VM *1, RDT159V *1, RDT155LM *1, MDT461S *1, MDT401S *1, MDT321S *1, MDT242WG, MDT221WG, MDT201WS *1, LDT461V, LDT421V, LDT321V

- *1 Not checked with GT16.

[Issue No.] GOT-A-0010-AC

9. Display Related Equipment: Image Transmitter and Receiver
(Compatible Product)

Manufacturer	Model
CONTEC CO., LTD	Transmitter: RP-VL-S-01 *1*2 Receiver: RP-VL-R-01 *2

- *1 This product can convert the analog RGB signals to the digital signals via Ethernet to transmit the screen images. For the RGB output from the GOT, the transmission distance can be extended. A dedicated receiver and others are required separately. For details, please refer to the manual of the manufacturer.
- *2 The operation is not checked with GT15.

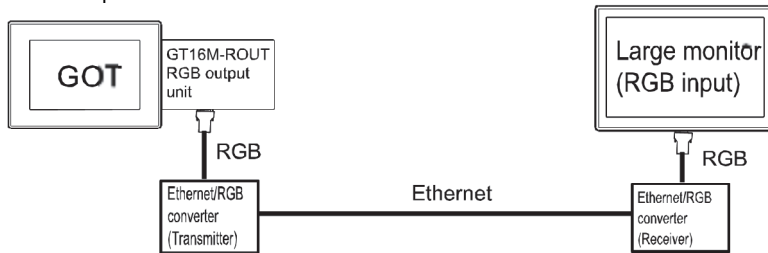

10. Speaker

For a sound output unit of the GOT, use a speaker with amplifier.
Use a speaker compatible with the following specifications.

Item	Specification
Sound output terminal	For connecting external L/R speakers, 1 channel for each speaker (2Vp-p, 0.4mW (for rated load 10kΩ))
Applicable jack	Φ3.5 stereo mini jack, straight type
Playable file	Windows WAV format 8.000kHz, 16 bits, mono (8 seconds/sound file)

11. RFID Controller

11.1 Compatible Products

Manufacturer	Model	Operation validation	
		GOT1000	GT SoftGOT1000 *1
LS Industrial Systems Co., Ltd.	LSRF-C	Supported	Supported
OMRON Corporation	V600/V620	Supported	Supported
MARS TOHKEN SOLUTION CO.LTD..	ICU-60S	Supported	Supported
	ICU-215	Supported	Not Supported
PONGEE INDUSTRIES CO., LTD	PUA-310	Supported	Supported

*1 GT SoftGOT1000 Version 3.28E or later is required.

11.2 System equipment of RFID controllers

The following shows the equipment to configure with different types of RFID controllers.

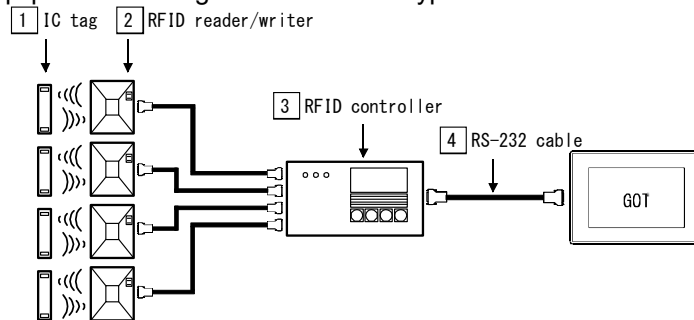

Manufacturer	1 IC tag	2 RFID reader/writer	3 RFID controller	4 RS-232 cable
LS Industrial Systems Co., Ltd.	LSRT125	LSRF-L	LSRF-C	Produced by the user Refer to (1) below *1
OMRON Corporation	V600-D□	V600-H□	V600-CA5D□	Produced by the user Refer to (2) below *1
	V620-D8KR01	V620-H□	V620-CA1A	Produced by the user Refer to (3) below *1
MARS TOHKEN SOLUTION CO.LTD..	Mifare(ISO14443 TypeA) card	ICU-60S (built-in a controller)		Produced by the user Refer to (4) below *1
		ICU-215 (built-in a controller)		Produced by the user Refer to (5) below *1
PONGEE INDUSTRIES CO., LTD	PUA-310-compatible tag	PUA-310 (built-in a controller)		Produced by the user Refer to (6) below *1

*1 To connect the RFID controller to GT SoftGOT2000, connect the following USB/RS-232 conversion cables to a USB port on the personal computer.

For the USB/RS-232 conversion cables, refer to Technical Bulletin FA-D-0036.

- DIFC-U2 (Diatrend Corporation)

- DAC01R2VD (Diatrend Corporation)

<Connection example>

[RFID controller (RS-232)] + [3 RS-232 cable] + [DAC01R2VD] + [DIFC-U2] + [Personal computer (USB)]

[Issue No.] GOT-A-0010-AC

(1) RS-232 cable connection diagram for an RFID controller manufactured by LS Industrial Systems Co., Ltd. The following shows connection cables that must be produced by the user. Maximum cable length: confirm with the RFID controller manufacturer.

RFID controller		Cable connection and signal direction	GOT	
Signal name	Pin No.		Pin No.	Signal name
NC	1		1	CD
RD(RXD)	2	←	2	RD(RXD)
SD(TXD)	3	→	3	SD(TXD)
NC	4		4	DTR(ER)
SG	5	←	5	SG
NC	6	←	6	DSR(DR)
NC	7		7	RS(RTS)
NC	8	←	8	CS(CTS)
NC	9		9	NC

* For the cables between [2] and [3], refer to the manual created by LS Industrial Systems Co., Ltd.

(2) RS-232 cable connection diagram for a V600 RFID controller manufactured by OMRON Corporation. The following shows connection cables that must be produced by the user. Maximum cable length: confirm with the RFID controller manufacturer.

RFID controller		Cable connection and signal direction	GOT	
Signal name	Pin No.		Pin No.	Signal name
-	1		1	CD *1
SD	2	→	2	RD(RXD)
RD	3	←	3	SD(TXD)
RS	4		4	DTR(ER)
CS	5	←	5	SG
-	6		6	DSR(DR)
-	7		7	RS(RTS)
-	8		8	CS(CTS)
SG	9	←	9	-

*1 NC for GT11

* For the cables between [2] and [3], refer to the manual created by OMRON Corporation

(3) RS-232 cable connection diagram for a V620 RFID controller manufactured by OMRON Corporation. The following shows connection cables that must be produced by the user. Maximum cable length: confirm with the RFID controller manufacturer.

RFID controller		Cable connection and signal direction	GOT	
Signal name	Pin No.		Pin No.	Signal name
FG	1		1	CD *1
SD	2	→	2	RD(RXD)
RD	3	←	3	SD(TXD)
RS	4		4	DTR(ER)
CS	5	←	5	SG
-	6		6	DSR(DR)
SG	7	←	7	RS(RTS)
-	8		8	CS(CTS)
ER	20		9	NC

*1 NC for GT11

* For the cables between [2] and [3], refer to the manual created by OMRON Corporation

[Issue No.] GOT-A-0010-AC

(4) RS-232 cable connection diagram for an ICU-60S RFID controller manufactured by MARS TOHKEN SOLUTION CO.LTD.

The following shows connection cables that must be produced by the user.

Maximum cable length: confirm with the RFID controller manufacturer.

RFID controller (ICU-60S)		Cable connection and signal direction	GOT	
Signal name	Pin No.		Pin No.	Signal name
+24V	1		1	CD *1
GND	2		2	RD(RXD)
TXD	3		3	SD(TXD)
RXD	4		4	DTR(ER)
CTS	5		5	SG
RTS	6		6	DSR(DR)
/RST	7		7	RS(RTS)
GND	8		8	CS(CTS)
-	9		9	NC

*1 NC for GT11

* For the cables between [2] and [3], refer to the manual created by MARS TECHNO SCIENCE Corp.

(5) RS-232 cable connection diagram for an ICU-215 RFID controller manufactured by MARS TOHKEN SOLUTION CO.LTD.

The following shows connection cables that must be produced by the user.

Maximum cable length: confirm with the RFID controller manufacturer.

RFID controller (ICU-215)		Cable connection and signal direction	GOT	
Signal name	Pin No.		Pin No.	Signal name
/RXD	1		1	CD *1
/TXD	2		2	RD(RXD)
+5V	3		3	SD(TXD)
GND	4		4	DTR(ER)
GND	5		5	SG
-	-		6	DSR(DR)
-	-		7	RS(RTS)
-	-		8	CS(CTS)
-	-		9	5V *2

*1 NC for GT11

*2 Supply 5VDC to the RFID controller.

* For the cables between [2] and [3], refer to the manual created by MARS TECHNO SCIENCE Corp.

[Issue No.] GOT-A-0010-AC

(6) RS-232 cable connection diagram for an ICU-215 RFID controller manufactured by PONGEE INDUSTRIES CO., LTD.

The following shows connection cables that must be produced by the user.

Maximum cable length: confirm with the RFID controller manufacturer.

RFID controller		Cable connection and signal direction	GOT	
Signal name	Color		Pin No.	Signal name
+12VDC	Red		1	CD *1
Ground	Black	←	2	RD(RXD)
TX+	White	→	3	SD(TXD)
Shield/Ground	Yellow		4	DTR(ER)
-	-		5	SG
-	-		6	DSR(DR)
-	-		7	RS(RTS)
-	-		8	CS(CTS)
-	-		9	-

*1 NC for GT11

* For the cables between [2](#) and [3](#), refer to the manual created by PONGEE INDUSTRIES CO., LTD

11.3 How to read data by an RFID controller

Please refer to the followings for the data transfer format (header/terminator settings and others) that can be used in the GOT or the setting method to read data by an RFID controller.

- (a) Data transfer format (header/terminator settings and others) that can be used in the GOT.
- (b) Setting to connect an RFID controller to the GOT. ([Peripheral Setting] on GT Designer3 or [Communication Settings] on GT Designer2)
- (c) Setting to write the data, read by an RFID controller, to the PLC CPU. ([Detail Setting] in the [Bar Code] dialog box on GT Designer3 or [Detail Setting] in the [Bar Code] dialog box on GT Designer2)
Refer to the following.

- GT Designer3 Version □ Screen Design Manual (Fundamentals) (SH-080866ENG)
- GT Designer2 Version □ Screen Design Manual (SH-080530ENG)

- (d) Setting procedure from connecting an RFID controller to the GOT until reading IC tag data.
Refer to the following.

- GOT1000 Series Connection Manual (Microcomputer, MODBUS Products, Peripherals) for GT Works3 (SH-080871ENG)
- GOT1000 Series Connection Manual (SH-080532ENG)

- (e) The send data and receive data for an RFID controller manufactured by MARS TOHKEN SOLUTION CO.LTD.

- 1) ICU-60S
Send data: Set the data except STX and ETX to LF.
Receive data: The data except STX and ETX to LF are stored.
- 2) ICU-215
Send data: Set the data except STX and BCC to ETX.
Receive data: The data except STX and BCC to ETX are stored.

[Issue No.] GOT-A-0010-AC

11.4 RFID Controllers Available for the External Authentication

The following RFID controllers are available for the external authentication.

Manufacturer	Model
LS Industrial Systems Co., Ltd.	LSRF-C
OMRON Corporation	V600/V620
PONGEE INDUSTRIES CO., LTD	PUA-310

12. Modem

To use a modem, **GT Designer3 Version1.01B** or later is required.

(Compatible Product)

Manufacturer	Model
I-O DATA DEVICE, INC. *1	DFML-560ER
Yokogawa Electric Corporation *1	TN30
MITSUBISHI ELECTRIC *2	MIM-A01
MITSUBISHI ELECTRIC *2	MIM-G01
SIXNET *3	VT-MODEM

*1 For Japan

*2 For overseas (Europe)

*3 For overseas (North America)

12.1 AT command list

Set AT commands according to a modem to be used.

AT commands to be used differ depending on whether the modem is connected to the GOT or the modem is connected to a personal computer.

For details of the AT commands, refer to the manual for each modem.

Model	Initialization command	
	Personal computer side *1	GOT side *2
DFML-560ER	AT&F0V1E0Q0%C0&K0&D0W2	AT&F0V1E0Q0%C0&K0&D0W2S0=1
TN30	AT&FV1E0Q0%C0&K0&D0W2	AT&FV1E0Q0%C0&K0&D0W2S0=1
MIM-A01 *3	AT&FV1E0Q0%C0&K0&D0W2+TFORMAT="8N1";+TBAUD="9600"	AT&FV1E0Q0%C0&K0&D0W2S0=1+TFORMAT="8N1";+TBAUD="9600"
MIM-G01 *4	AT&FE0%C0&K0&D0+CICB=0;+IPR=9600;+ICF=3,4;+IFC=0,0	AT&FE0%C0&K0&D0S0=1+CICB=0;+IPR=9600;+ICF=3,4;+IFC=0,0
VT-MODEM	AT&FQ0E0V1%C0&K0&D0W2	AT&FQ0E0V1%C0&K0&D0W2S0=1

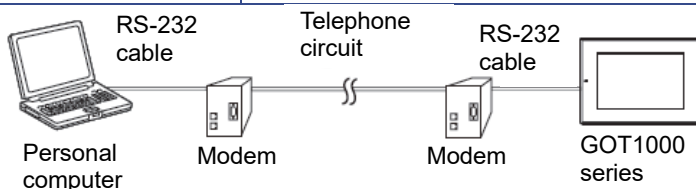

*1 Enter a command in the initialization command field for GOT Modem Connection Tool.

*2 Enter a command in the initialization command field of [Detail Setting] in the [I/F Communication Setting] dialog box on GT Designer3.

*3 Configure a communication setting of the MIM-A01 by using AT commands. To configure the setting, use AT commands (+TBAUD and +TFORMAT). The example shows the case when the baud rate is 9600bps, the data length is 8 bits, the parity is none, and the stop bit is 1 bit.

*4 Configure a communication setting of the MIM-G01 by using AT commands. To configure the setting, use AT commands (+IPR and +ICF). The example shows the case when the baud rate is 9600bps, the data length is 8 bits, the parity is none, and the stop bit is 1 bit.

12.2 Connection cable

12.2.1 Connection cable between a personal computer and a modem

Model	Connection cable
	Between personal computer and modem
DFML-560ER TN30	(1) Cable 1)
MIM-A01 MIM-G01	(2) Cable 2)
VT-MODEM	(1) Cable 1)

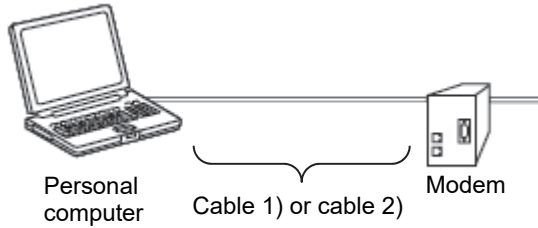

(1) Cable 1)

A cable included with a modem is available. To create a cable by the user, refer to the following cable connection diagram.

The cable length must be up to 15m.

Personal computer Pin No.	Cable connection	Modem Pin No.
1		1
2		2
3		3
4		4
5		5
6		6
7		7
8		8
9		9

[Issue No.] GOT-A-0010-AC

(2) Cable 2)

Create a cable by referring to the following cable connection diagram. The cable length must be up to 15m.

Personal computer Pin No.	Cable connection	Modem Pin No.
1		1
2		2
3		3
4		4
5		5
6		6
7		7
8		8
9		9

12.2.2 Connection cable between a modem and the GOT

- GT16, GT15, GT11, GT105□, GT104□

Model	Connection cable Between modem and GOT
DFML-560ER	(1) Cable 3)
TN30	
MIM-A01	
MIM-G01	
VT-MODEM	

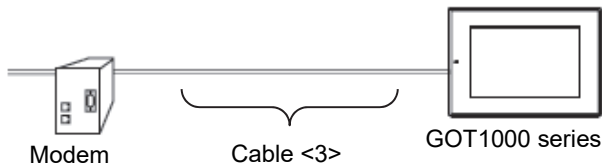

- GT1020, GT1030

For the connection between a modem and the GOT, a cable included with the modem and the GT10-C02H-6PT9P are required.

Model	Connection cable Between modem and GOT
DFML-560ER	(1) Cable 3)+GT10-C02H-6PT9P
TN30	
MIM-A01	
MIM-G01	
VT-MODEM	

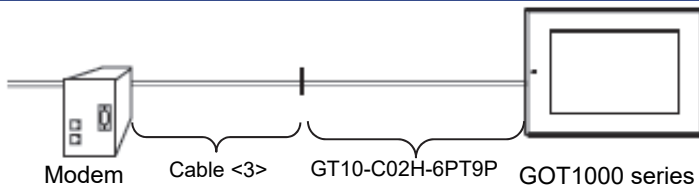

[Issue No.] GOT-A-0010-AC

(1) Cable 3)

A cable included with a modem is available. To create a cable by the user, refer to the following cable connection diagram.

The cable length must be up to 15m.

Modem	Cable connection	GOT
Pin No.		Pin No.
1		1
2		2
3		3
4		4
5		5
6		6
7		7
8		8
9		9

13. USB Keyboard

A USB keyboard is available for the GT16 and GT14.

To use a USB keyboard, the GT16 requires **GT Works3 Version 1.10L** or later, and the GT14 requires **GT Works3 Version 1.37P** or later.

Item	Specification
USB keyboard	Japanese 106 keyboard, English 101 keyboard, and forward-compatible keyboards (Japanese 109 keyboard and others) *1*2

*1 Only keys compatible with Japanese 106 keyboards and English 101 keyboards are available. (Keys other than on Japanese 106 keyboards or on an English 101 keyboards are invalid.)

*2 A keyboard with a particular function and others may not be available depending on the keyboard type.

14. USB Mouse Function

A USB keyboard is available for the GT16 and GT14.

To use a USB keyboard, the GT16 requires **GT Works3 Version 1.10L** or later, and the GT14 requires **GT Works3 Version 1.37P** or later.

Item	Specification
USB mouse	2 or 3-button USB mouse *1

*1 A particular USB mouse and others may not be available depending on the USB mouse type.

Particular function examples:

A composite device (a device with a USB hub function, a card reader, a numeric keypad, or others), a 4-button mouse, and a mouse whose functions are added by dedicated driver software

15. USB Hub

A USB keyboard is available for the GT16 and GT14.

To use a USB keyboard, the GT16 requires **GT Works3 Version 1.10L** or later, and the GT14 requires **GT Works3 Version 1.37P** or later.

Item	Specification
USB hub	USB hub compatible with USB1.1 (including forward-compatible USB hubs)*1

*1: A particular hub and others may not be available depending on the USB hub type.

Particular function examples:

A hub with 5 or more ports, a hub with multiple hubs, and a composite device with functions other than a hub function

REVISIONS

Version	Print Date	Revision
N	February 2010	- Revised the contents of "2. USB Memory" - Added models to "11. RFID Controller"
P	-	- Revised the contents of "2. USB Memory" - Added the models to "6. Printer" - Added the models to "12. Modem"
Q	-	- Revised the contents of "2. USB Memory"
R	October 2010	- Added "5. Hubs for Ethernet Connection and Gateway Function"
S	December 2010	- Added the models to "3. Barcode Reader" - Added the models to "4. 2D Code Reader" - Added the models to "5. Hubs for Ethernet Connection and Gateway Function"
T	April 2011	- Added the operation validation with GT SoftGOT1000 to "3. Barcode Reader", "4. 2D Code Reader"
U	May 2011	- Added the models to "4. 2D Code Reader"
V	-	- Added the models to "3. Barcode Reader" - Added the models to "4. 2D Code Reader" - Revised the whole composition
W	-	- Added the models to "3. Barcode Reader"
X	-	- Corrected the writing in "3. Barcode Reader"
Y	-	- Corrected the cable connection diagram for OMRON barcode readers
Z	-	- Revised the contents in "7. Video Camera" - Revised the contents in "8. Display"
AA	January 2014	- Added the models to "3. Barcode Reader"
AB	December 2014	- Added the models to "4. 2D Code Reader"
AC	December 2019	- Revised the annotation of "6.2 Serial printer"

QR Code is a trademark or registered trademark of DENSO WAVE INCORPORATED in Japan, the United States, and/or other countries.

Other company and product names herein are trademarks or registered trademarks of their respective owners.