

Proposal of replacement by Global PM motor EM-A series

Application examples



Transport application

Positioning is possible
without a sensor
(encoder)

Other features

- Improved work speed and stopping accuracy.
- Not subject to high-efficiency laws and regulations of various countries, and can be used safely for overseas projects.

Before

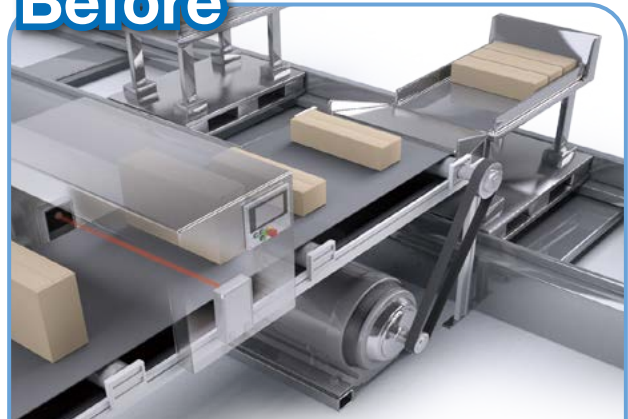

[Current] Mitsubishi inverter + General purpose motor (+ proximity sensor)

After

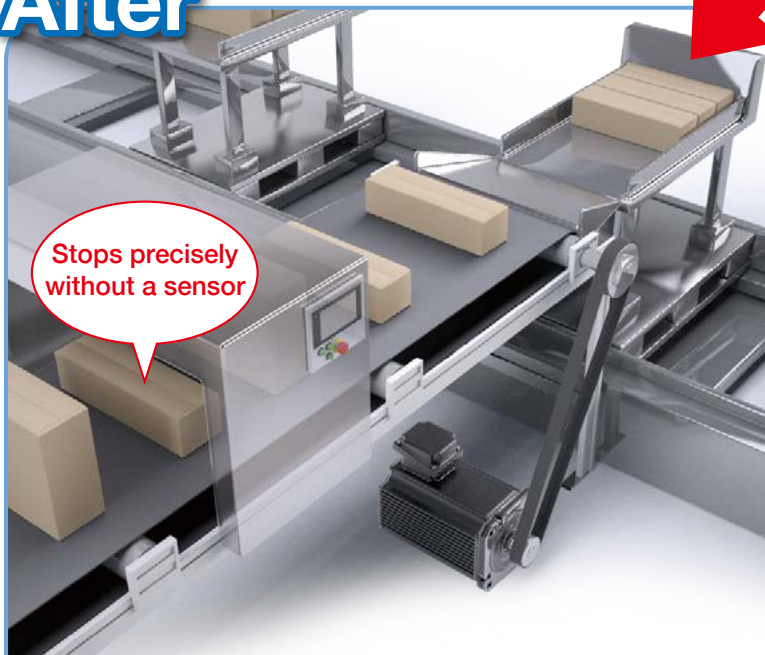

[Suggested] FR-E700EX+EM-A

Induction motor

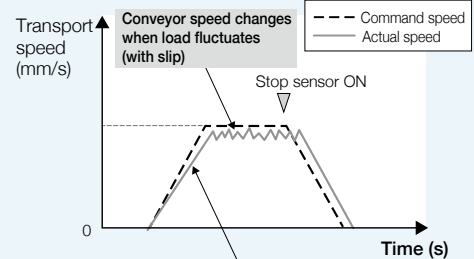

Variation in repeated operating pattern precision
* Without sensorless servo control

EM-A

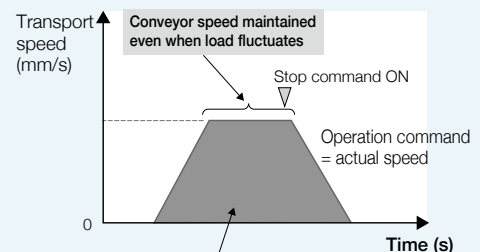

Good repeated operating pattern precision
* Consistent operation pattern area can be ensured with fixed-position conveyance

Polishing application



**High precision
speed control**

**Maximum rotation speed
4000 r/min**

Point of replacement

Existing motors change rotation speed due to load fluctuation during high speed rotation. By replacing those motors with the EM-A series, they can operate at stable speeds that are resistant to load fluctuations.

Speed fluctuation
rate is *1

±0.05%

* For digital input

Maximum torque is

200%

- The EM-A series uses Mitsubishi's unique PM sensorless vector control to achieve high-precision speed control with minimal speed fluctuation even when the load changes.

*1: Continuous operating torque is 80% in the low speed range (15 r/min or less).

When high load operation is performed in the low speed range (15 r/min or less), electronic thermal protection (E.THT, E.THM) may be activated and it may not be possible to produce torque in the the short-time operating range.

[Operating torque characteristics]

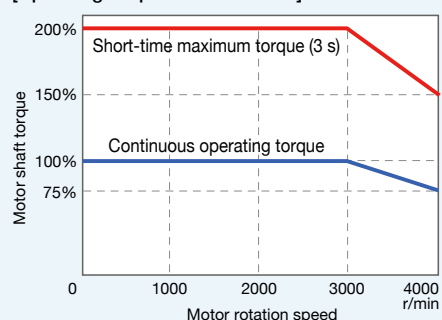

MITSUBISHI ELECTRIC CORPORATION

HEAD OFFICE: TOKYO BLDG., 2-7-3 MARUNOUCHI, CHIYODA-KU, TOKYO 100-8310, JAPAN

Proposal of replacement by Global PM motor EM-A series

Application examples



Clean room applications

Reducing dust emission

All EM-A series are fully enclosed and self-cooling, so they do not have cooling fans, do not scatter dust, and do not disturb the airflow in clean rooms.

[Other features]

- The completely sealed structure of the unit, even with a brake, provides peace of mind.
- IP65 compliance is also available.

Before

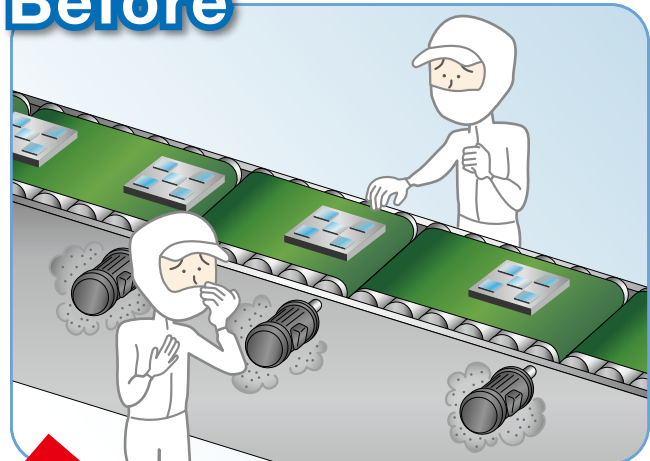

After

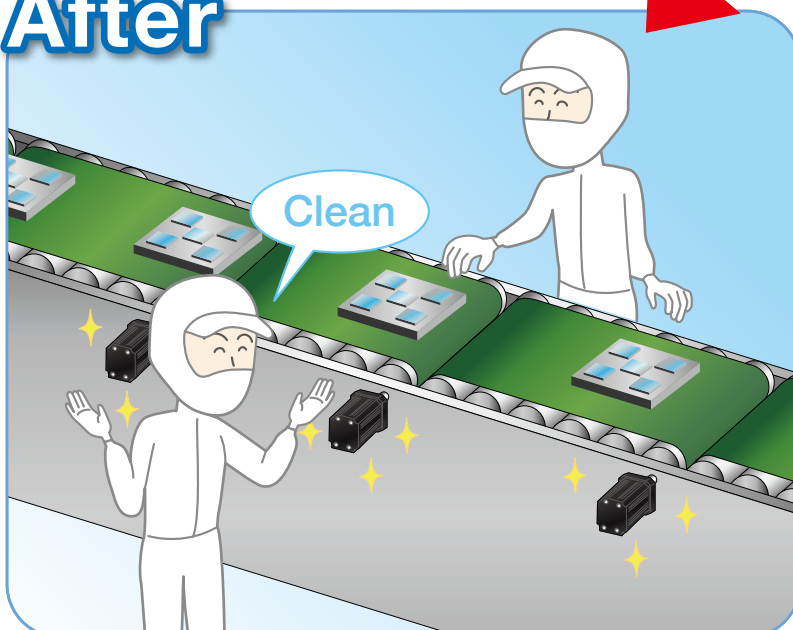

Induction motor

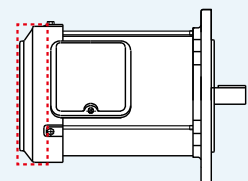

EM-A series

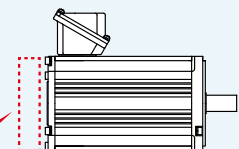

No cooling fan!

- The EM-A series, including those with brakes, do not use cooling fans.

Pump application

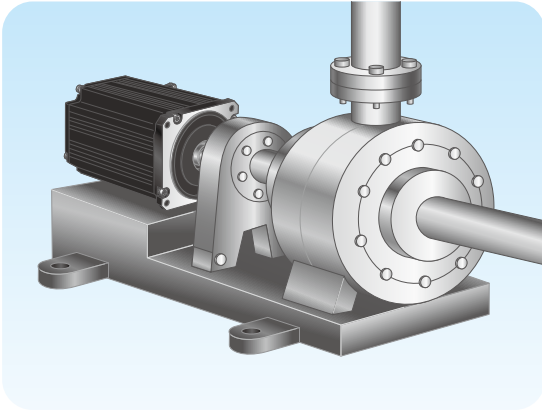

Torque in the low speed range

The speed control range is wide and the torque is good even at low speeds.
(Speed control range 1:1300)

High precision speed control

Compared to induction motors, these new motors provide high precision speed control with less speed fluctuation.
(Speed fluctuation rate is $\pm 0.05\%$)

Speed fluctuation rate is *1

$\pm 0.05\%$

* For digital input

Maximum torque is

200%

- The EM-A series uses Mitsubishi's unique PM sensorless vector control to achieve high-precision speed control with minimal speed fluctuation even when the load changes.
- These motors can operate at stable speeds that are resistant to load fluctuations.

*1: Continuous operating torque is 80% in the low speed range (15 r/min or less).
When high load operation is performed in the low speed range (15 r/min or less), electronic thermal protection (E.THT, E.THM) may be activated and it may not be possible to produce torque in the short-time operating range.

[Operating torque characteristics]

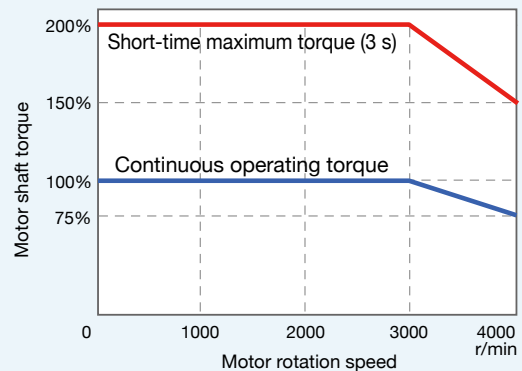

MITSUBISHI ELECTRIC CORPORATION

HEAD OFFICE: TOKYO BLDG., 2-7-3 MARUNOUCHI, CHIYODA-KU, TOKYO 100-8310, JAPAN