

MITSUBISHI ELECTRIC CORPORATION
PUBLIC RELATIONS DIVISION
7-3, Marunouchi 2-chome, Chiyoda-ku, Tokyo, 100-8310 Japan

FOR IMMEDIATE RELEASE

No. 3058

Customer Inquiries

Power Distribution Systems Center
Mitsubishi Electric Corporation
[www.MitsubishiElectric.com/ssl/contact/
bu/powersystems/form](http://www.MitsubishiElectric.com/ssl/contact/bu/powersystems/form)
[www.MitsubishiElectric.com/products/
energy/index.html](http://www.MitsubishiElectric.com/products/energy/index.html)

Media Inquiries

Public Relations Division
Mitsubishi Electric Corporation
prd.gnews@nk.MitsubishiElectric.co.jp
www.MitsubishiElectric.com/news/

Mitsubishi Electric to Build HVDC Verification Facility at Transmission and Distribution Systems Center

*Will launch voltage-sourced converter (VSC) based high voltage direct current (HVDC) systems
business globally*

TOKYO, October 12, 2016 – [Mitsubishi Electric Corporation](http://www.MitsubishiElectric.com) (TOKYO: 6503) announced today that it will enter the global market for voltage-sourced converters (VSC) based high-voltage direct current (HVDC) systems with a new HVDC verification facility to be built at its Transmission and Distribution Center in Amagasaki, Japan by 2018. The company is targeting more than US\$ 500 million in global orders for HVDC -Diamond[®] systems by 2020.



Rendition of Mitsubishi Electric's HVDC Verification Facility

HVDC systems are expected to reduce CO₂ through the efficient integration and expansion of renewable energies, such as photovoltaic and offshore wind power. HVDC-Diamond[®] systems will utilize the company's own high-voltage insulated gate bipolar transistors (HVIGBT).

HVIGBT devices are insulated for high voltage and designed for large current ratings to reduce the number of sub-modules, resulting in space and cost savings. The parallel connectivity of the HVIGBT devices in each sub-module allows for a flexible design to meet wide-ranging needs for power transmission capacities in the global market for VSC-based HVDC systems.

HVDC-Diamond[®] will offer high reliability through the use of high speed control and protection systems. Optimized control functions with appropriate hardware configuration will comply with system requirements for stable and continuous operation, even during faults on the AC network such as lightning strikes. Protection systems with high speed response will ensure all equipment can be effectively protected from high currents generated at the time of DC faults within the HVDC system.

There are two types of HVDC systems; the line-commutated converter (LCC) type requires an external power source for commutation, while the VSC type does not. VSC-based HVDC systems are expected to be in greater demand with a more compact footprint as a result of having the innate ability of separately controlling active and reactive power. This advantage allows for applying VSC-based HVDC in weak systems and removes the need for additional reactive compensation from harmonic filters and other reactive voltage support.

Mitsubishi Electric is launching the business of VSC-based HVDC globally in response to the various needs of modern power systems and will implement its verification facility aiming to be operational in the first part of 2018 for the verification of HVDC-Diamond[®]. The global market for HVDC systems, estimated to have been worth about US\$ 5 billion in 2015, is expected to grow by about seven percent annually.

HVDC Verification Facility

Location	8-1-1 Tsukaguchi-Honmachi, Amagasaki, Hyogo Prefecture, Japan
Building Area	Approx. 1,250 square meters (approx. 13,450 square feet)
Floor Space	Approx. 1,700 square meters (approx. 18,300 square feet)
Structure	Two-story steel-frame
Start of Operation	First half of 2018
Specification	50MW VSC-based HVDC BTB*
Main facility	Converter, Control and protection, AC equipment

* HVDC BTB (back-to-back): HVDC system which transfers energy between AC buses at the same location.

About Mitsubishi Electric’s VSC HVDC-Diamond[®] Systems

VSC-based HVDC systems consist of multiple AC/DC converter stations and DC connectors, such as cables or overhead lines. HVDC-Diamond[®] is the brand name for the components and technologies encompassing the converter station and the control and protection system governing the HVDC system.

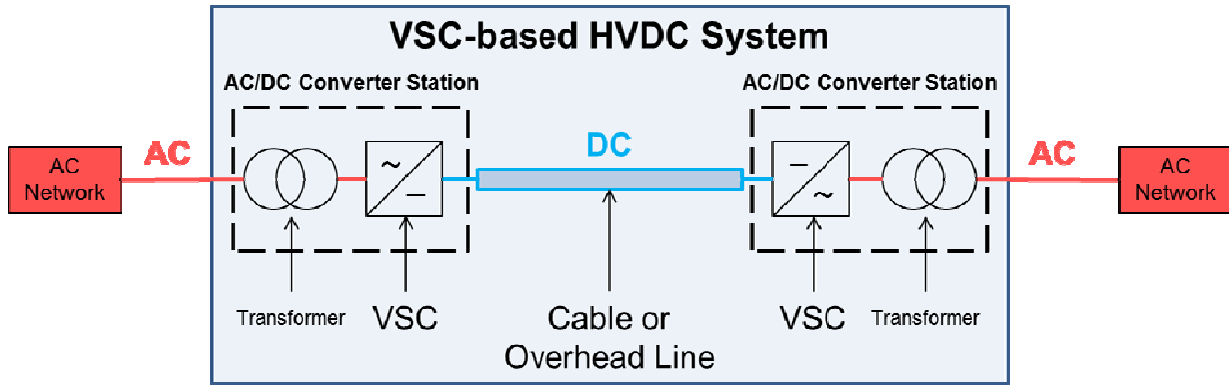

Example VSC-based HVDC Configuration **

** This outline is simplified for explanatory purpose. Actual system configuration may vary.

HVDC-Diamond is a registered trademark of Mitsubishi Electric Corporation.

###

About Mitsubishi Electric Corporation

With over 90 years of experience in providing reliable, high-quality products, Mitsubishi Electric Corporation (TOKYO: 6503) is a recognized world leader in the manufacture, marketing and sales of electrical and electronic equipment used in information processing and communications, space development and satellite communications, consumer electronics, industrial technology, energy, transportation and building equipment. Embracing the spirit of its corporate statement, Changes for the Better, and its environmental statement, Eco Changes, Mitsubishi Electric endeavors to be a global, leading green company, enriching society with technology. The company recorded consolidated group sales of 4,394.3 billion yen (US\$ 38.8 billion*) in the fiscal year ended March 31, 2016. For more information visit:

www.MitsubishiElectric.com

*At an exchange rate of 113 yen to the US dollar, the rate given by the Tokyo Foreign Exchange Market on March 31, 2016