

< Silicon RF Power MOS FET (Discrete) >

RD00LUS2

RoHS Compliance, Silicon MOSFET Power Transistor, 520MHz, 0.5W, 3.6V

DESCRIPTION

RD00LUS2 is a MOS FET type transistor designed for VHF/UHF RF driver device.

FEATURES

High power gain and High Efficiency.
 $P_{out}=0.7W_{typ}$, $G_p=18.5dB_{typ}$, Drain Effi.=60% $_{typ}$
 @ $V_{DD}=3.6V$, $I_{dq}=60mA$,
 $P_{in}=10mW$, $f=520MHz$
 Integrated gate protection diode.

APPLICATION

For output stage of high-power amplifiers in VHF/UHF-band mobile radio sets.

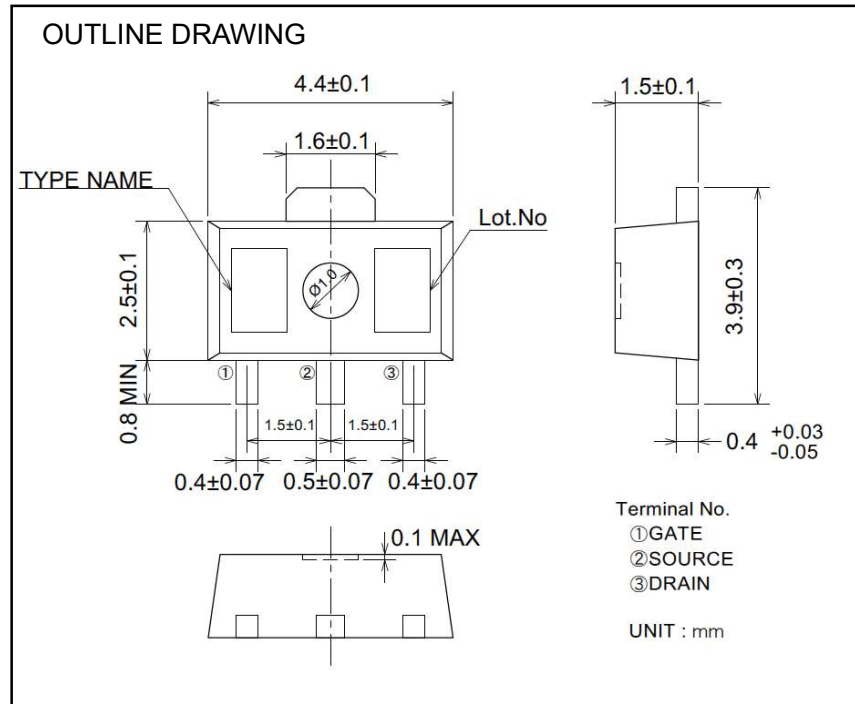

RoHS COMPLIANT

RD00LUS2 is RoHS compliant product.

This product includes the lead in high melting temperature type solders.

However, it is applicable to the following exceptions of RoHS Directions.

1. Lead in high melting temperature type solders (i.e.tin-lead solder alloys containing more than85% lead.)

ORDERING INFORMATION

ORDER NUMBER	SUPPLY FORM
RD00LUS2-501	Stick (25pcs / Stick), for evaluation
RD00LUS2-T513	Tape & Reel (3,000pcs/reel)

RD00LUS2

RoHS Compliance, Silicon MOSFET Power Transistor, 520MHz, 0.5W, 3.6V

ABSOLUTE MAXIMUM RATINGS (Ta=25°C UNLESS OTHERWISE NOTED)

SYMBOL	PARAMETER	CONDITIONS	RATING	UNIT
V _{DSS}	Drain to Source Voltage	V _{GS} =0V	25	V
V _{GSS}	Gate to Source Voltage	V _{DS} =0V	-5/+10	V
P _D *	Power Dissipation	T _c =25°C	17	W
P _{in}	Input Power	f=520MHz	150	mW
I _{DS}	Drain Current	-	0.9	A
T _{j (op)}	Operating Junction Temperature	-	+150	°C
T _{stg}	Storage Temperature	-	-40 to +125	°C

Note: Above parameters are guaranteed independently.

* Theoretical value in case of mounted on infinite heat sink.

ELECTRICAL CHARACTERISTICS (Ta=25°C, UNLESS OTHERWISE NOTED)

SYMBOL	PARAMETER	TEST CONDITIONS	LIMIT			UNIT
			MIN	TYP	MAX.	
I _{DSS}	Drain cutoff current	V _{DS} =17V, V _{GS} =0V	-	-	50	μA
I _{GSS}	Gate cutoff current	V _{GS} =10V, V _{DS} =0V	-	-	1	μA
V _{th}	Gate threshold Voltage	V _{DS} =7.2V, I _{DS} =1.8mA	0.5	-	1.5	V
P _{out}	Output power	f=520MHz, V _{DD} =3.6V	0.5	0.7	-	W
η _D	Drain efficiency	P _{in} =10mW, I _{dq} =60mA	50	60	-	%

Note: Above parameters, ratings, limits and conditions are subject to change.

THERMAL CHARACTERISTICS (Ta=25°C UNLESS OTHERWISE NOTED)

SYMBOL	PARAMETER	TEST CONDITIONS	LIMIT			UNIT
			MIN	TYP	MAX	
R _{thj-c}	Thermal Resistance	ΔVF method	-	4.5	7	°C /W

RD00LUS2

RoHS Compliance, Silicon MOSFET Power Transistor, 520MHz, 0.5W, 3.6V

TYPICAL CHARACTERISTICS

(These are only typical curves and devices are not necessarily guaranteed at these curves.)

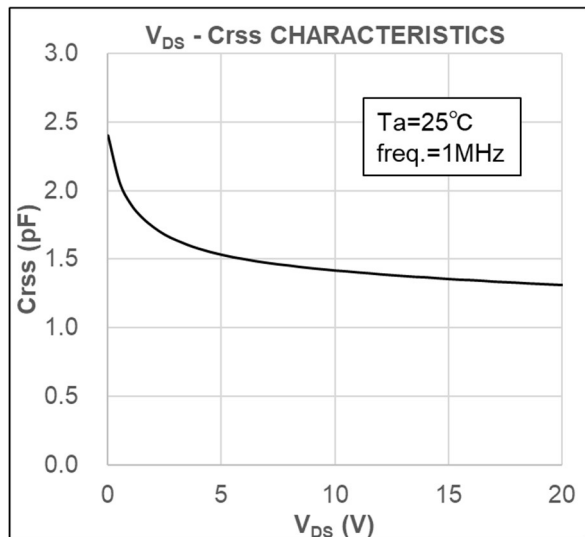
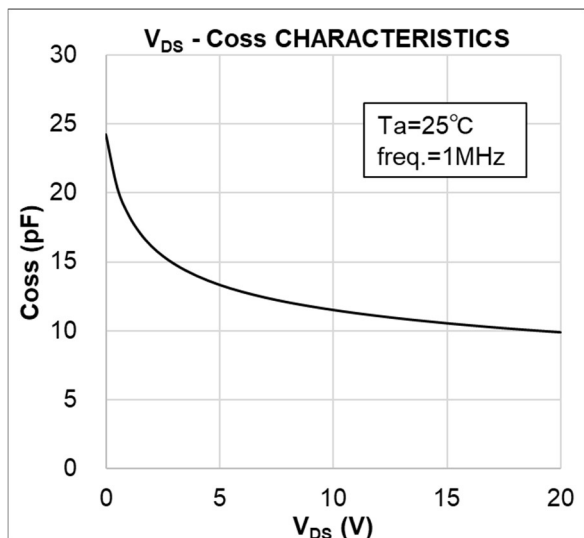
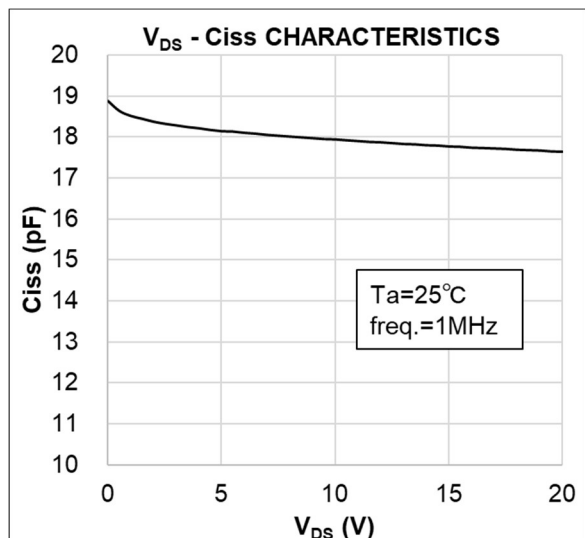
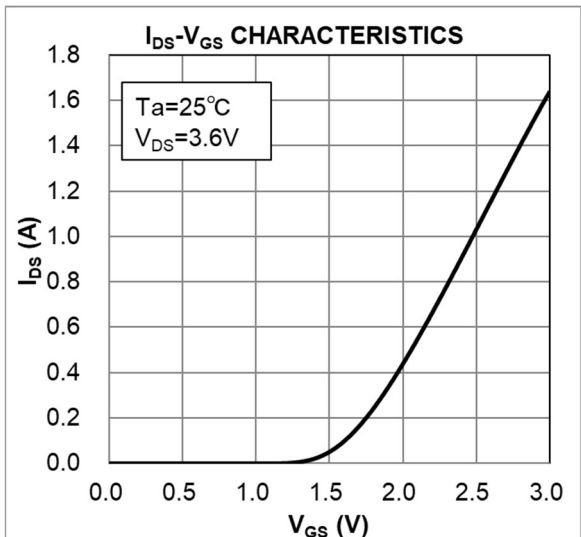
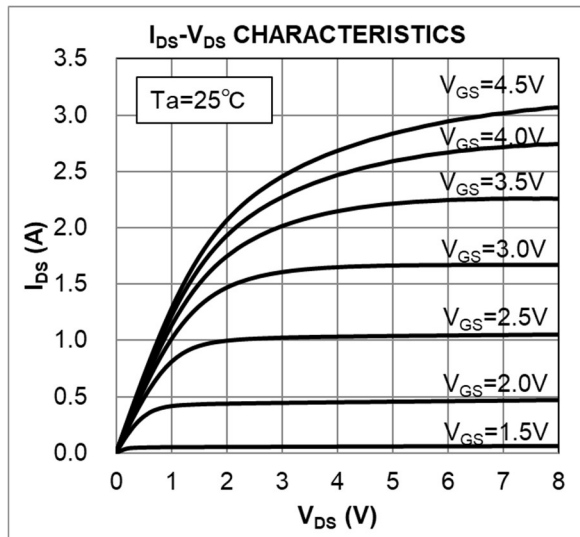

RD00LUS2

RoHS Compliance, Silicon MOSFET Power Transistor, 520MHz, 0.5W, 3.6V

TYPICAL CHARACTERISTICS WITH TEST FIXTURE (f=520MHz, Ta=25°C)

(These are only typical curves and devices are not necessarily guaranteed at these curves.)

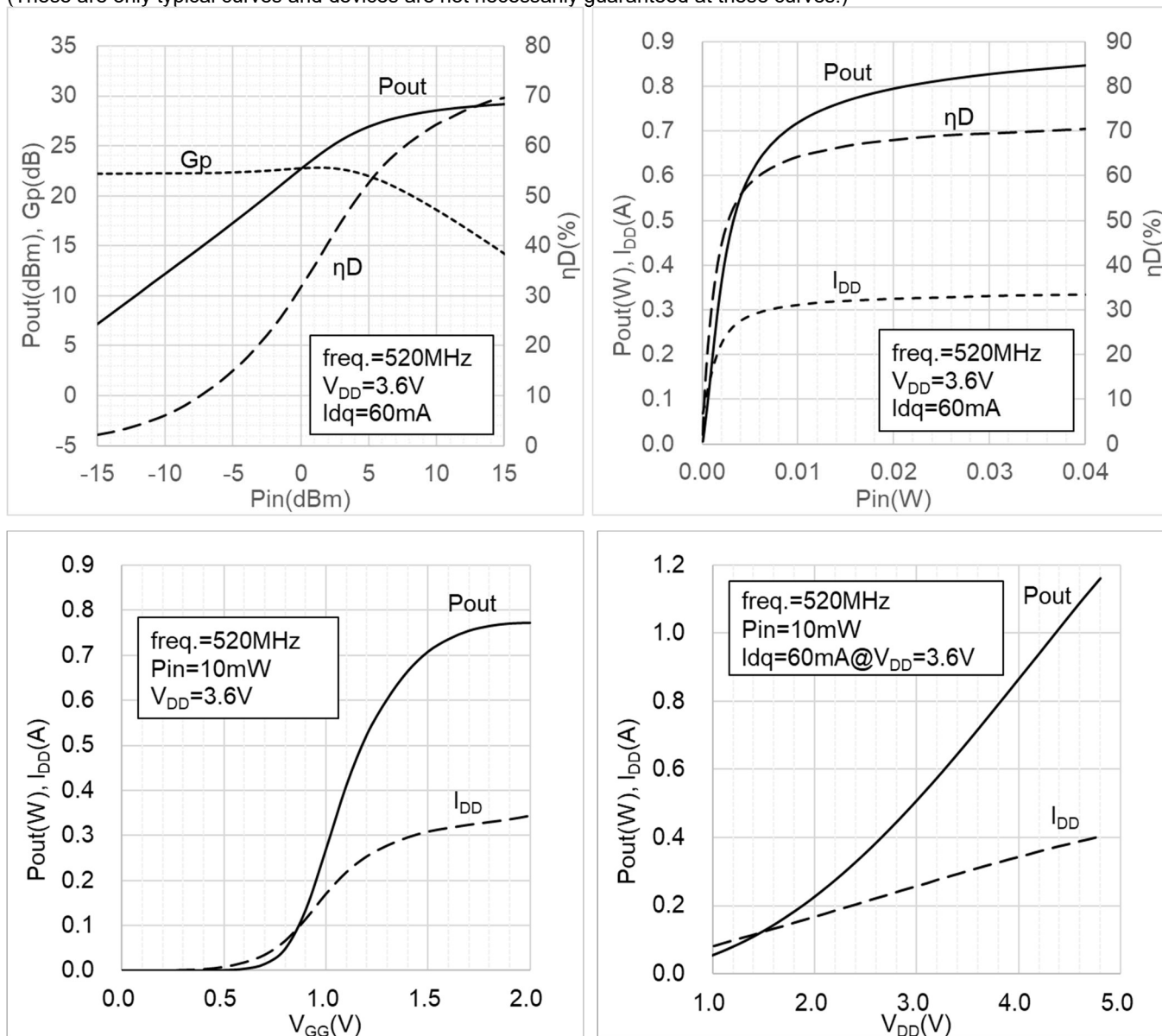

RD00LUS2

RoHS Compliance, Silicon MOSFET Power Transistor, 520MHz, 0.5W, 3.6V

Equivalent Circuitry of TEST FIXTURE (f=520MHz)

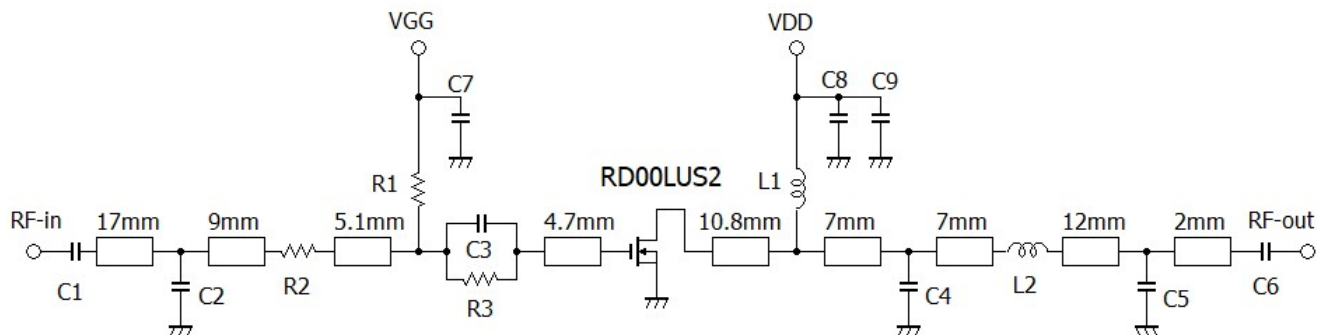

PCB:Glass-epoxy($\epsilon_r=4.7$, $t=0.8\text{mm}$)

Component List of TEST FIXTURE (f=520MHz)

Parts Type	Part	Description
Capacitor	C1, C6	100 pF
	C2	24 pF
	C3	68 pF
	C4	20 pF
	C5	2 pF
	C7, C8	1000 pF
	C9	47 μ F
Inductor	L1	37nH (Enameled wire $\Phi 0.4\text{mm}$, 7 Turns, outside Φ :2.46mm)
	L2	12nH (Enameled wire $\Phi 0.23\text{mm}$, 3 Turns, outside Φ :1.62mm)
Resistor	R1	4700 Ω
	R2	1 Ω
	R3	100 Ω

RD00LUS2

RoHS Compliance, Silicon MOSFET Power Transistor, 520MHz, 0.5W, 3.6V

TYPICAL CHARACTERISTICS WITH EVB (f=380-470MHz, Ta=25°C)

(These are only typical curves and devices are not necessarily guaranteed at these curves.)

Frequency characteristics @ $P_{in} = 10 \text{ dBm}$ (10mW), $V_{DD} = 3.6\text{V}$, $I_{dq} = 60\text{mA}$

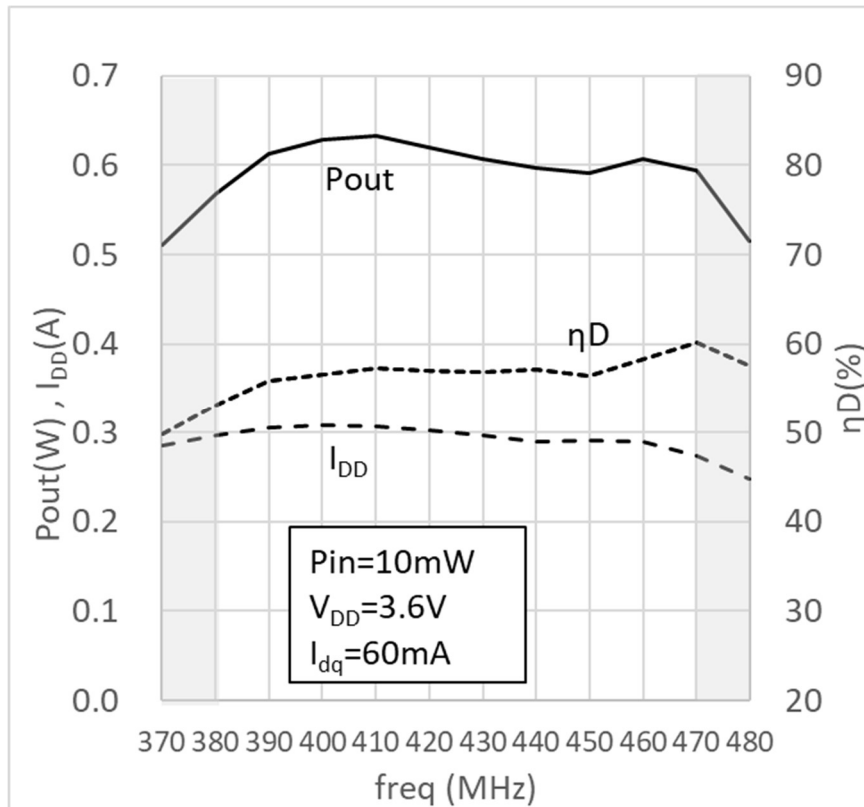

RD00LUS2

RoHS Compliance, Silicon MOSFET Power Transistor, 520MHz, 0.5W, 3.6V

TYPICAL CHARACTERISTICS WITH EVB (f=380-470MHz, Ta=25°C)

(These are only typical curves and devices are not necessarily guaranteed at these curves.)

P_{out} vs. P_{in} characteristics @ V_{DD} = 3.6V, I_{dq} = 60mA

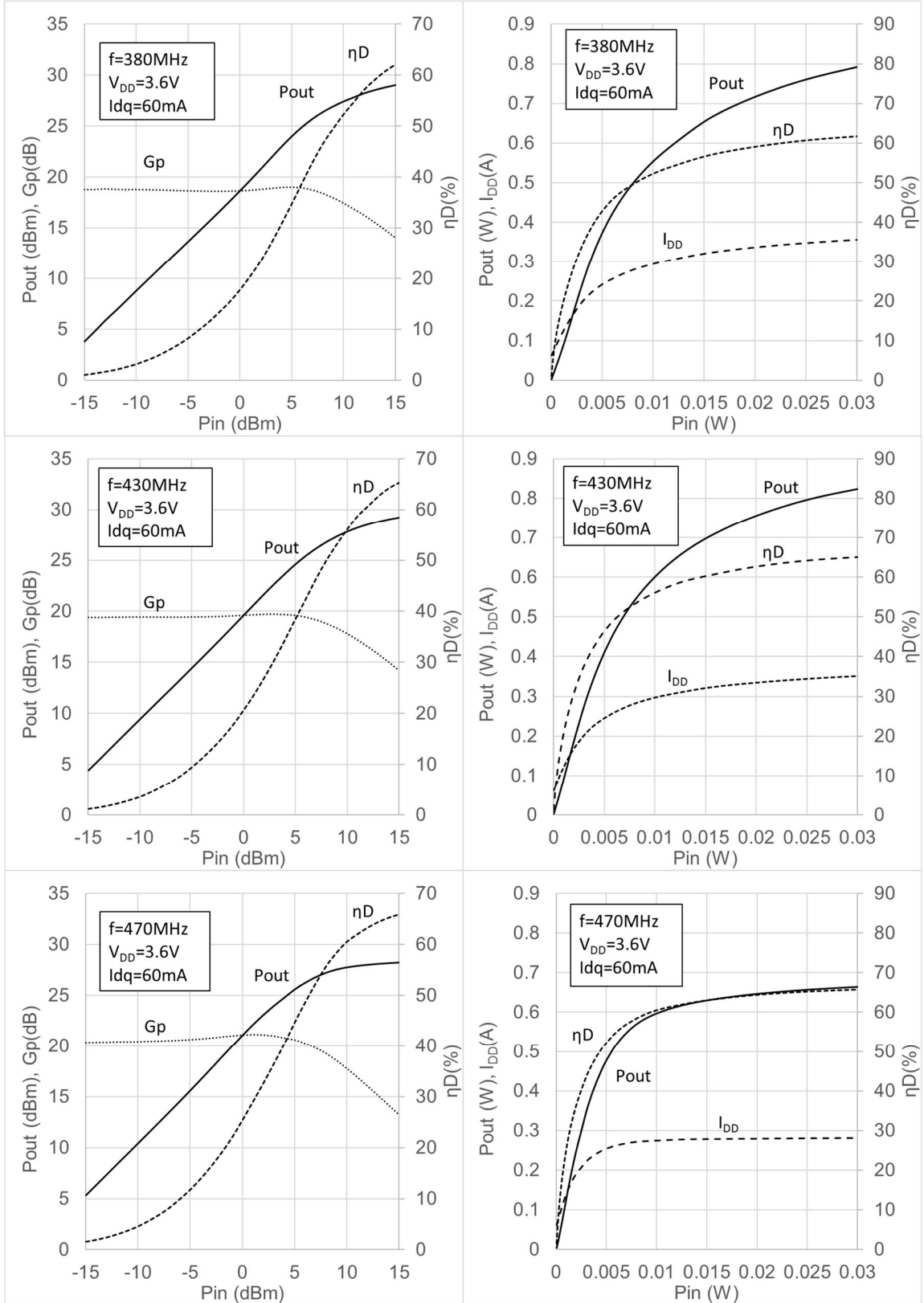

RD00LUS2

RoHS Compliance, Silicon MOSFET Power Transistor, 520MHz, 0.5W, 3.6V

TYPICAL CHARACTERISTICS WITH EVB (f=380-470MHz, Ta=25°C)

(These are only typical curves and devices are not necessarily guaranteed at these curves.)

P_{out} vs. V_{GG} characteristics @ V_{DD}= 3.6V, P_{in}= 10dBm (10mW)

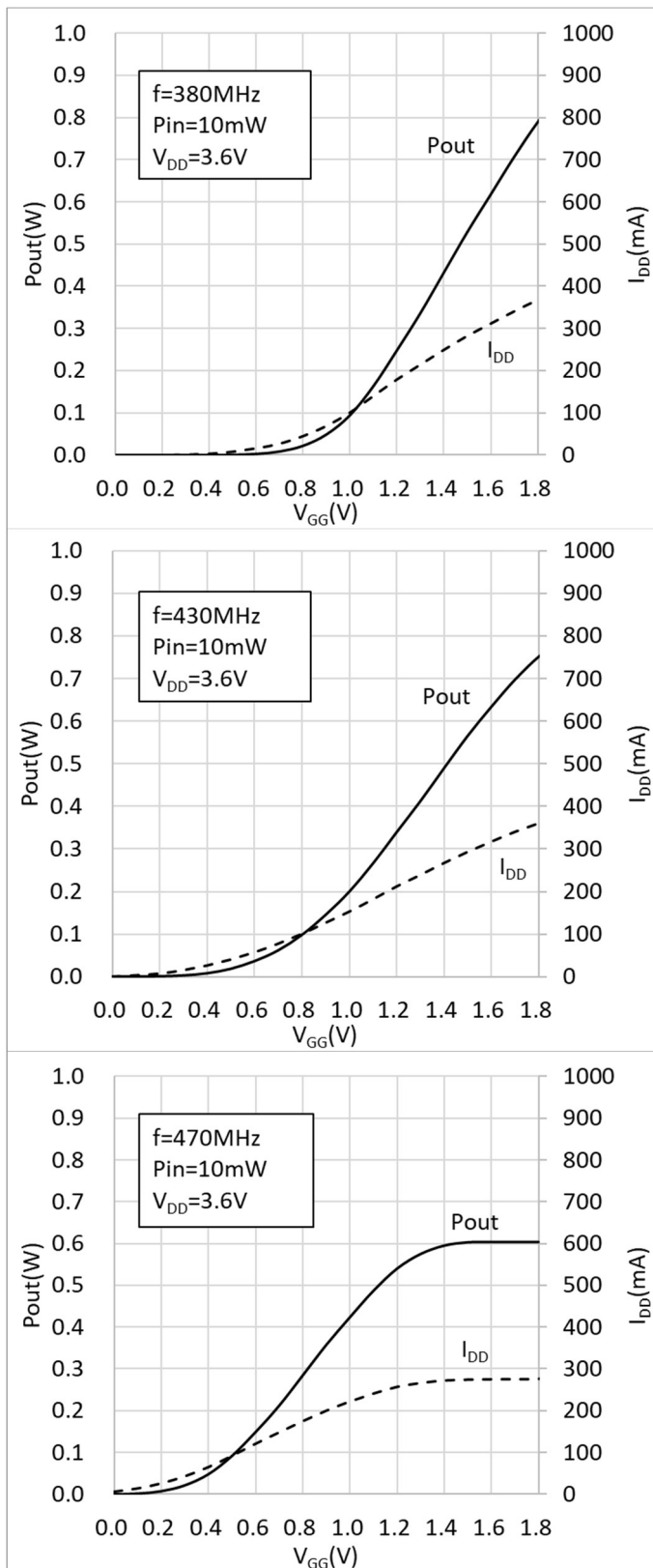

RD00LUS2

RoHS Compliance, Silicon MOSFET Power Transistor, 520MHz, 0.5W, 3.6V

TYPICAL CHARACTERISTICS WITH EVB (f=380-470MHz, Ta=25°C)

(These are only typical curves and devices are not necessarily guaranteed at these curves.)

P_{out} vs. V_{DD} characteristics @I_{dq}=60mA(@V_{DD}=3.6V), P_{in}= 10dBm (10mW)

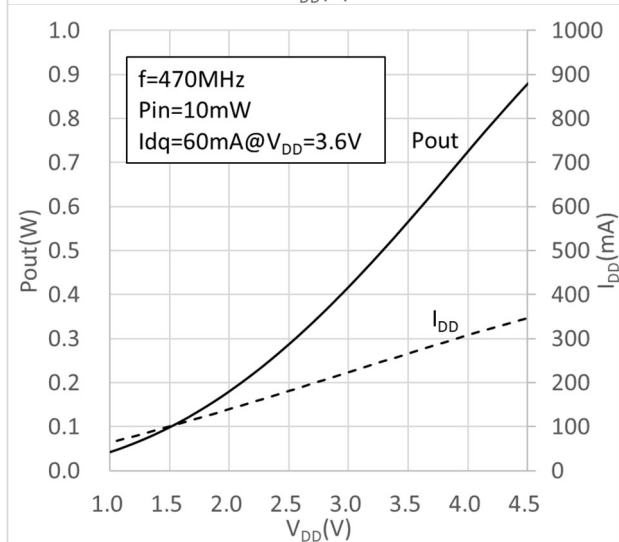
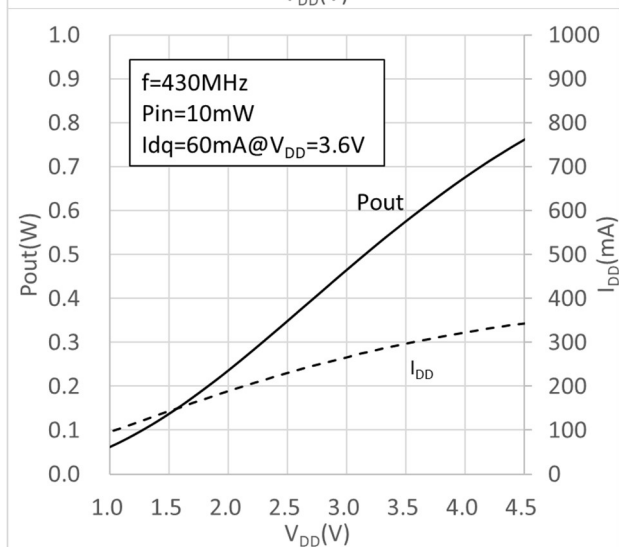
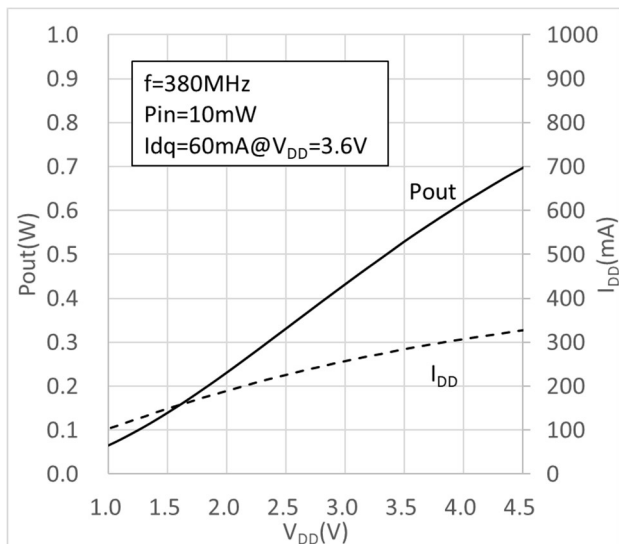

RD00LUS2

RoHS Compliance, Silicon MOSFET Power Transistor, 520MHz, 0.5W, 3.6V

Input / Output Impedance of EVB (f=380-470MHz)

Z_{in}^* (f=380, 430, 470MHz)

$Z_o=50\Omega$

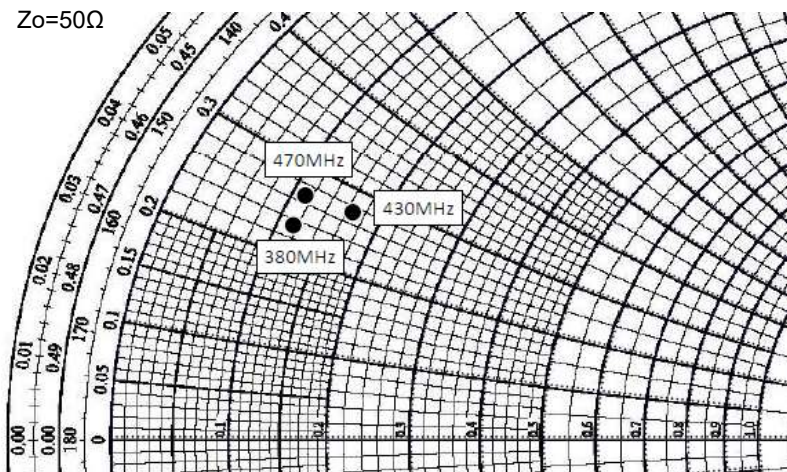

f (MHz)	Z_{in}^* (Ω)
380	5.74 + j 11.56
430	8.26 + j 13.53
470	5.59 + j 13.28

Z_{in}^* : Complex conjugate of input impedance

Z_{out}^* (f=380, 430, 470MHz)

$Z_o=50\Omega$

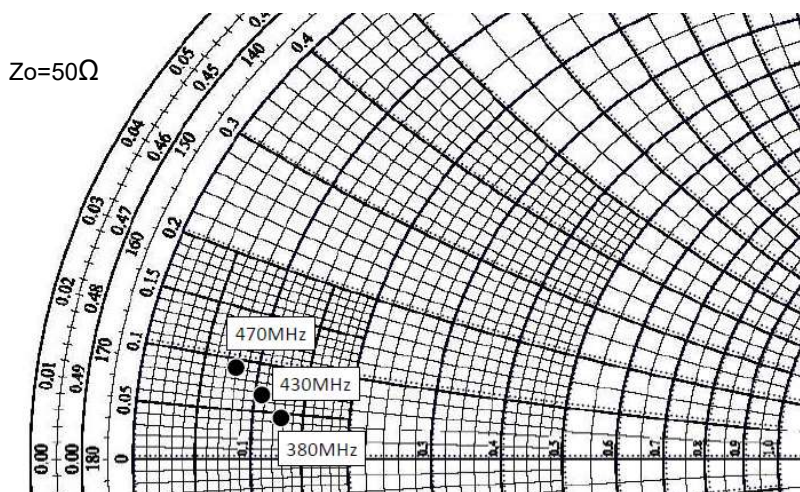

f (MHz)	Z_{out}^* (Ω)
380	6.32 + j 2.04
430	5.29 + j 3.16
470	3.91 + j 4.37

Z_{out}^* : Complex conjugate of output impedance

Measurement Method of Input / Output Impedance

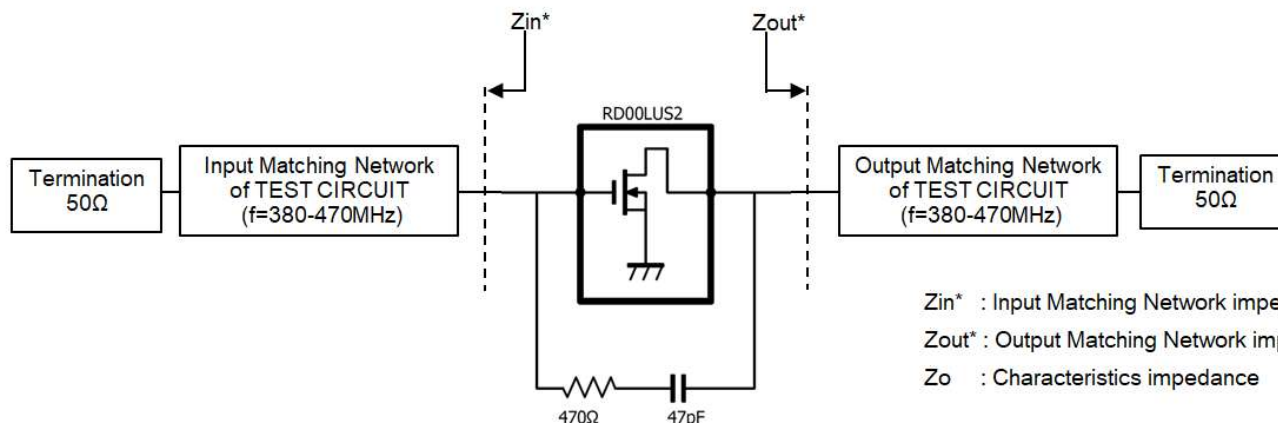

Z_{in}^* : Input Matching Network impedance
 Z_{out}^* : Output Matching Network impedance
 Z_o : Characteristics impedance

RD00LUS2

RoHS Compliance, Silicon MOSFET Power Transistor, 520MHz, 0.5W, 3.6V

Equivalent Circuitry of EVB (f=380-470MHz)

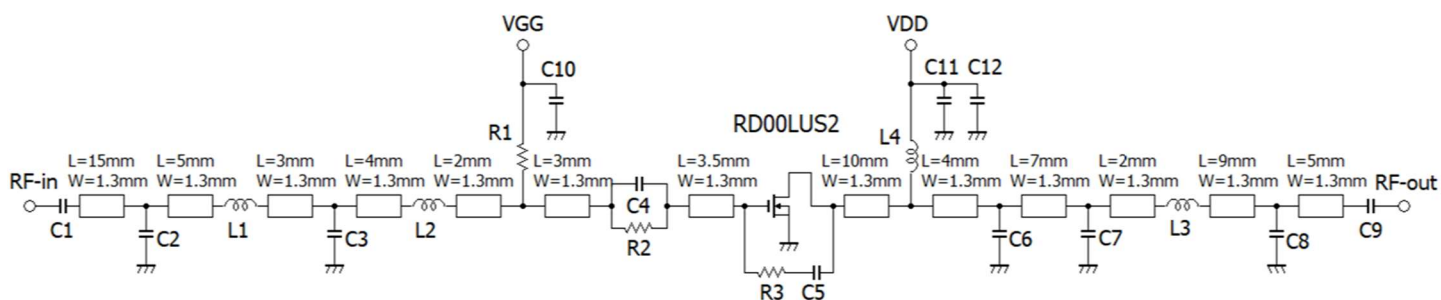

PCB:Glass-epoxy($\epsilon r=4.7$, $t=0.8\text{mm}$)

Component List of EVB (f=380-470MHz)

	No.	Description	Part number	Manufacturer
Capacitor	C1, C9	100 pF	GQM1875C2E101JB12	MURATA MANUFACTURING CO.
	C2	20 pF	GQM1872C2E200JB12	MURATA MANUFACTURING CO.
	C3, C5	47 pF	GQM1872C2E470JB12	MURATA MANUFACTURING CO.
	C4	62 pF	GQM1875C2E620JB12	MURATA MANUFACTURING CO.
	C6	27 pF	GQM1872C2E270JB12	MURATA MANUFACTURING CO.
	C7	13 pF	GQM1872C2E130JB12	MURATA MANUFACTURING CO.
	C8	8 pF	GQM1875C2E8R0DB12	MURATA MANUFACTURING CO.
	C10, C11	1000 pF	GRM1882C1H102JA01	MURATA MANUFACTURING CO.
	C12	22 μ F	UVZ1H220MDD	NICHICON CORPORATION

	No.	Description	Part number	Manufacturer
Inductor	L1	5.6 nH	LQG18HN5N6S00	MURATA MANUFACTURING CO.
	L2	4.7 nH	LQG18HN4N7S00	MURATA MANUFACTURING CO.
	L3	12nH Enameled wire $\Phi 0.23\text{mm}$ 3 turns, outside Φ : 1.62mm	2303S	YC Corporation Co.,Ltd.
	L4	22nH Enameled wire $\Phi 0.4\text{mm}$ 5 turns, outside Φ : 2.46mm	4005C	YC Corporation Co.,Ltd.

	No.	Description	Part number	Manufacturer
Resistor	R1	4700 Ω	RPC05-472	TAIYOSHA ELECTRIC CO.
	R2	56 Ω	RPC05-560	TAIYOSHA ELECTRIC CO.
	R3	470 Ω	RPC05-471	TAIYOSHA ELECTRIC CO.

RD00LUS2

RoHS Compliance, Silicon MOSFET Power Transistor, 520MHz, 0.5W, 3.6V

S-PARAMETER DATA of DEVICE

$V_{DS}=3.6V$, $I_{dq}=60mA$, $T_a=25^{\circ}C$

Freq. (MHz)	S11		S21		S12		S22	
	(mag)	(ang)	(mag)	(ang)	(mag)	(ang)	(mag)	(ang)
100	0.79	-106	19.80	111	0.037	22	0.66	-101
135	0.77	-121	15.90	101	0.039	12	0.64	-115
155	0.76	-127	14.20	96	0.039	8	0.63	-120
175	0.76	-131	12.77	92	0.040	4	0.63	-125
200	0.75	-137	11.26	87	0.040	0	0.63	-130
300	0.76	-149	7.43	73	0.038	-14	0.66	-141
380	0.78	-155	5.66	63	0.036	-22	0.69	-147
400	0.79	-156	5.33	61	0.036	-24	0.70	-148
430	0.79	-158	4.87	58	0.035	-26	0.71	-150
470	0.80	-160	4.36	55	0.034	-29	0.73	-152
500	0.81	-161	4.02	52	0.033	-31	0.74	-154
520	0.82	-162	3.82	50	0.032	-33	0.75	-154
600	0.84	-165	3.14	44	0.030	-38	0.78	-158
700	0.86	-169	2.52	37	0.027	-43	0.81	-162
800	0.88	-172	2.06	31	0.024	-48	0.84	-166
900	0.89	-175	1.72	25	0.021	-51	0.86	-169
1000	0.90	-178	1.45	20	0.018	-54	0.87	-172
1100	0.91	179	1.24	16	0.015	-56	0.89	-175
1200	0.92	177	1.07	11	0.013	-57	0.90	-178
1300	0.93	174	0.94	7	0.011	-57	0.91	180
1400	0.93	172	0.82	4	0.009	-55	0.92	177
1500	0.94	169	0.73	0	0.008	-50	0.92	175

RD00LUS2

RoHS Compliance, Silicon MOSFET Power Transistor, 520MHz, 0.5W, 3.6V

ATTENTION:

- 1.High Temperature ; This product might have a heat generation while operation,Please take notice that have a possibility to receive a burn to touch the operating product directly or touch the product until cold after switch off. At the near the product,do not place the combustible material that have possibilities to arise the fire.
- 2.Generation of High Frequency Power ; This product generate a high frequency power. Please take notice that do not leakage the unnecessary electric wave and use this products without cause damage for human and property per normal operation.
- 3.Before use; Before use the product,Please design the equipment in consideration of the risk for human and electric wave obstacle for equipment.

PRECAUTIONS FOR THE USE OF MITSUBISHI SILICON RF POWER DEVICES:

1. The specifications of mention are not guarantee values in this data sheet. Please confirm additional details regarding operation of these products from the formal specification sheet. For copies of the formal specification sheets, please contact one of our sales offices.
- 2.RA series products (RF power amplifier modules) and RD series products (RF power transistors) are designed for consumer mobile communication terminals and were not specifically designed for use in other applications. In particular, while these products are highly reliable for their designed purpose, they are not manufactured under a quality assurance testing protocol that is sufficient to guarantee the level of reliability typically deemed necessary for critical communications elements and In the application, which is base station applications and fixed station applications that operate with long term continuous transmission and a higher on-off frequency during transmitting, please consider the derating, the redundancy system, appropriate setting of the maintain period and others as needed. For the reliability report which is described about predicted operating life time of Mitsubishi Silicon RF Products , please contact Mitsubishi Electric Corporation or an authorized Mitsubishi Semiconductor product distributor.
3. RD series products use MOSFET semiconductor technology. They are sensitive to ESD voltage therefore appropriate ESD precautions are required.
4. In the case of use in below than recommended frequency, there is possibility to occur that the device is deteriorated or destroyed due to the RF-swing exceed the breakdown voltage.
5. In order to maximize reliability of the equipment, it is better to keep the devices temperature low. It is recommended to utilize a sufficient sized heat-sink in conjunction with other cooling methods as needed (fan, etc.) to keep the channel temperature for RD series products lower than 120deg/C(in case of Tchmax=150deg/C) ,140deg/C(in case of Tchmax=175deg/C) under standard conditions.
6. Do not use the device at the exceeded the maximum rating condition. In case of plastic molded devices, the exceeded maximum rating condition may cause blowout, smoldering or catch fire of the molding resin due to extreme short current flow between the drain and the source of the device. These results causes in fire or injury.
7. For specific precautions regarding assembly of these products into the equipment, please refer to the supplementary items in the specification sheet.
8. Warranty for the product is void if the products protective cap (lid) is removed or if the product is modified in any way from it's original form.
9. For additional "Safety first" in your circuit design and notes regarding the materials, please refer the last page of this data sheet.
10. Please avoid use in the place where water or organic solvents can adhere directly to the product and the environments with the possibility of caustic gas, dust, salinity, etc. Reliability could be markedly decreased and also there is a possibility failures could result causing a serious accident. Likewise, there is a possibility of causing a serious accident if used in an explosive gas environment. Please allow for adequate safety margin in your designs.
11. Please refer to the additional precautions in the formal specification sheet.

RD00LUS2

RoHS Compliance, Silicon MOSFET Power Transistor, 520MHz, 0.5W, 3.6V

Keep safety first in your circuit designs!

Mitsubishi Electric Corporation puts the maximum effort into making semiconductor products better and more reliable, but there is always the possibility that trouble may occur with them. Trouble with semiconductors may lead to personal injury, fire or property damage. Remember to give due consideration to safety when making your circuit designs, with appropriate measures such as (i) placement of substitutive, auxiliary circuits, (ii) use of non-flammable material or (iii) prevention against any malfunction or mishap.

Notes regarding these materials

- These materials are intended as a reference to assist our customers in the selection of the Mitsubishi Electric Semiconductor product best suited to the customer's application; they do not convey any license under any intellectual property rights, or any other rights, belonging to Mitsubishi Electric Corporation or a third party.
- Mitsubishi Electric Corporation assumes no responsibility for any damage, or infringement of any third-party's rights, originating in the use of any product data, diagrams, charts, programs, algorithms, or circuit application examples contained in these materials.
- All information contained in these materials, including product data, diagrams, charts, programs and algorithms represents information on products at the time of publication of these materials, and are subject to change by Mitsubishi Electric Corporation without notice due to product improvements or other reasons. It is therefore recommended that customers contact Mitsubishi Electric Corporation or an authorized Mitsubishi Electric Semiconductor product distributor for the latest product information before purchasing a product listed herein.
The information described here may contain technical inaccuracies or typographical errors. Mitsubishi Electric Corporation assumes no responsibility for any damage, liability, or other loss rising from these inaccuracies or errors.
Please also pay attention to information published by Mitsubishi Electric Corporation by various means, including the Mitsubishi Electric Semiconductor home page (<http://www.MitsubishiElectric.com/semiconductor/>).
- When using any or all of the information contained in these materials, including product data, diagrams, charts, programs, and algorithms, please be sure to evaluate all information as a total system before making a final decision on the applicability of the information and products. Mitsubishi Electric Corporation assumes no responsibility for any damage, liability or other loss resulting from the information contained herein.
- Mitsubishi Electric Corporation semiconductors are not designed or manufactured for use in a device or system that is used under circumstances in which human life is potentially at stake. Please contact Mitsubishi Electric Corporation or an authorized Mitsubishi Electric Semiconductor product distributor when considering the use of a product contained herein for any specific purposes, such as apparatus or systems for transportation, vehicular, medical, aerospace, nuclear, or undersea repeater use.
- The prior written approval of Mitsubishi Electric Corporation is necessary to reprint or reproduce in whole or in part these materials.
- If these products or technologies are subject to the Japanese export control restrictions, they must be exported under a license from the Japanese government and cannot be imported into a country other than the approved destination.
Any diversion or re-export contrary to the export control laws and regulations of Japan and/or the country of destination is prohibited.
- Please contact Mitsubishi Electric Corporation or an authorized Mitsubishi Electric Semiconductor product distributor for further details on these materials or the products contained therein.