

< DIIPM >

PSS35SA2FT

TRANSFER MOLDING TYPE
INSULATED TYPE

OUTLINE

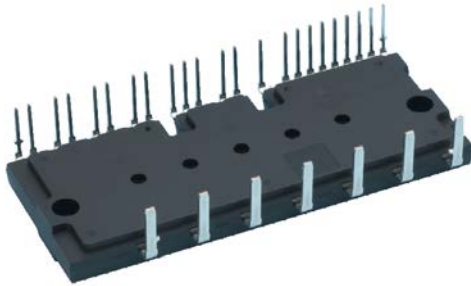

MAIN FEATURES AND RATINGS

- 3 phase DC/AC inverter
- 1200V / 35A
- Built-in LPT-CSTBT (6th generation IGBT)
- Built-in bootstrap diodes with current limiting resistor
- Insulated transfer molding package
- N-side IGBT open emitter

APPLICATION

- AC 400V class motor control

INTEGRATED DRIVE, PROTECTION AND SYSTEM CONTROL FUNCTIONS

- For P-side : Drive circuit, High voltage high-speed level shifting, Control supply under-voltage (UV) protection
- For N-side : Drive circuit, Control supply under-voltage protection (UV), Short circuit protection (SC)
- Fault signaling : Corresponding to SC fault (N-side IGBT), UV fault (N-side supply)
- Temperature output : Outputting LVIC temperature by analog signal
- Input interface : 5V line, Schmitt trigger receiver circuit (High Active)
- UL Recognized : UL1557 File E80276

INTERNAL CIRCUIT

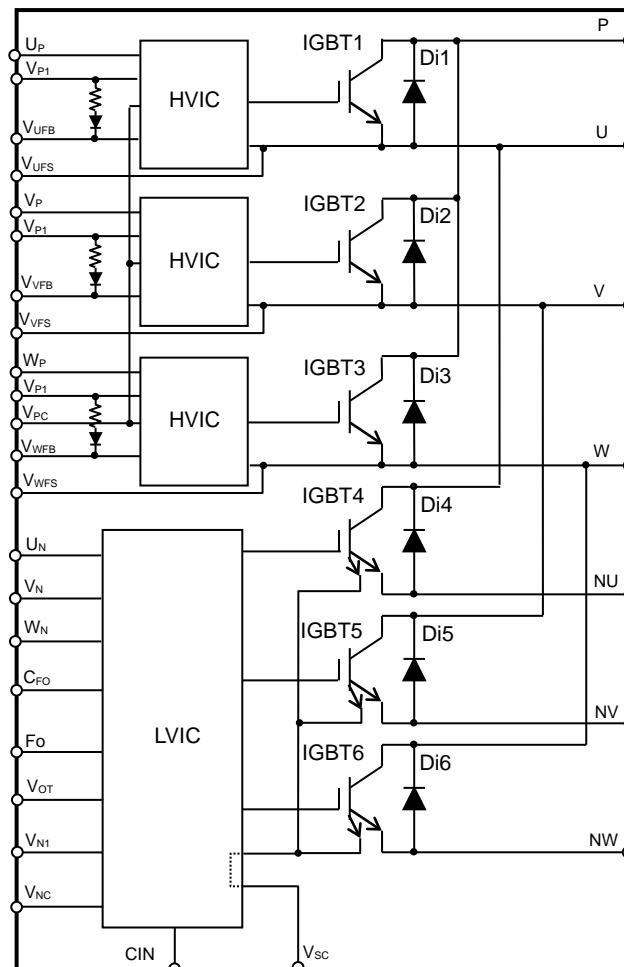

PSS35SA2FT

TRANSFER MOLDING TYPE
INSULATED TYPE

MAXIMUM RATINGS (T_j = 25°C, unless otherwise noted)

INVERTER PART

Symbol	Parameter	Condition	Ratings	Unit
V _{CC}	Supply voltage	Applied between P-NU,NV,NW	900	V
V _{CC(surge)}	Supply voltage (surge)	Applied between P-NU,NV,NW	1000	V
V _{CES}	Collector-emitter voltage		1200	V
±I _C	Each IGBT collector current	T _C = 25°C (Note 1)	35	A
±I _{CP}	Each IGBT collector current (peak)	T _C = 25°C, up to 1ms	70	A
P _C	Collector dissipation	T _C = 25°C, per 1 chip	117.6	W
T _j	Junction temperature		-30~+150	°C

Note 1: Pulse width and period are limited due to junction temperature.

CONTROL (PROTECTION) PART

Symbol	Parameter	Condition	Ratings	Unit
V _D	Control supply voltage	Applied between V _{P1} -V _{PC} , V _{N1} -V _{NC}	20	V
V _{DB}	Control supply voltage	Applied between V _{UFB} -V _{UFS} , V _{VFB} -V _{VFS} , V _{WFB} -V _{WFS}	20	V
V _{IN}	Input voltage	Applied between U _P , V _P , W _P -V _{PC} , U _N , V _N , W _N -V _{NC}	-0.5~V _D +0.5	V
V _{FO}	Fault output supply voltage	Applied between F _O -V _{NC}	-0.5~V _D +0.5	V
I _{FO}	Fault output current	Sink current at F _O terminal	5	mA
V _{SC}	Current sensing input voltage	Applied between CIN-V _{NC}	-0.5~V _D +0.5	V

TOTAL SYSTEM

Symbol	Parameter	Condition	Ratings	Unit
V _{CC(PROT)}	Self protection supply voltage limit (Short circuit protection capability)	V _D = 13.5~16.5V, Inverter Part T _j = 125°C, non-repetitive, up to 2μs	800	V
T _C	Module case operation temperature	T _c measurement point is defined in Fig.1.	-30~+100	°C
T _{stg}	Storage temperature		-40~+125	°C
V _{iso}	Isolation voltage	60Hz, Sinusoidal, AC 1min, between connected all pins and heat sink plate	2500	V _{rms}

Fig. 1: T_c MEASUREMENT POINT

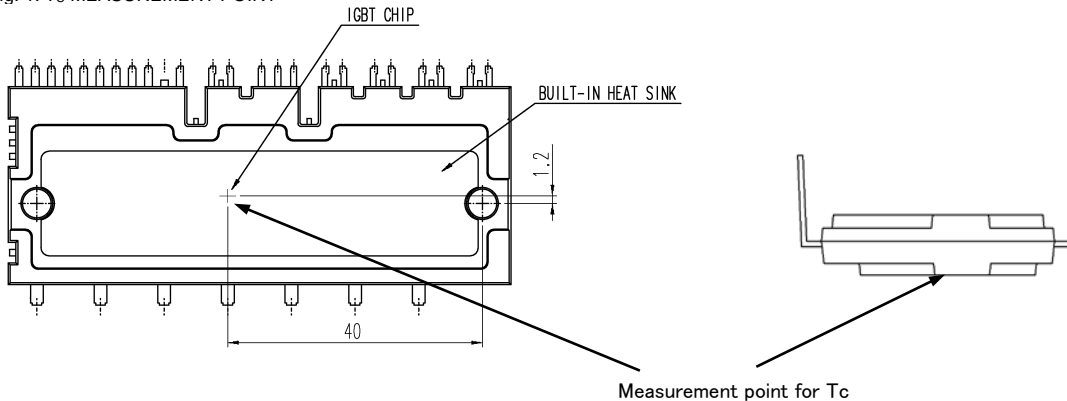

THERMAL RESISTANCE

Symbol	Parameter	Condition	Limits			Unit
			Min.	Typ.	Max.	
R _{th(i-c)Q}	Junction to case thermal resistance (Note 2)	Inverter IGBT part (per 1/6 module)	-	-	0.85	K/W
R _{th(i-c)F}		Inverter FWDi part (per 1/6 module)	-	-	1.25	K/W

Note 2: Grease with good thermal conductivity and long-term endurance should be applied evenly with about +100μm~+200μm on the contacting surface of DIIPM and heat sink. The contacting thermal resistance between DIIPM case and heat sink R_{th(c-f)} is determined by the thickness and the thermal conductivity of the applied grease. For reference, R_{th(c-f)} is about 0.2K/W (per 1/6 module, grease thickness: 20μm, thermal conductivity: 1.0W/m·k).

ELECTRICAL CHARACTERISTICS ($T_j = 25^\circ\text{C}$, unless otherwise noted)
INVERTER PART

Symbol	Parameter	Condition	Limits			Unit	
			Min.	Typ.	Max.		
$V_{CE(sat)}$	Collector-emitter saturation voltage	$V_D=V_{DB} = 15\text{V}$, $V_{IN}= 5\text{V}$, $I_C= 35\text{A}$	$T_j= 25^\circ\text{C}$	-	1.50	2.20	V
			$T_j= 125^\circ\text{C}$	-	1.70	2.40	
V_{EC}	FWDi forward voltage	$V_{IN}= 0\text{V}$, $-I_C= 35\text{A}$	-	2.20	2.80	V	
t_{on}	Switching times	$V_{CC}= 600\text{V}$, $V_D= V_{DB}= 15\text{V}$ $I_C= 35\text{A}$, $T_j= 125^\circ\text{C}$, $V_{IN}= 0\leftrightarrow 5\text{V}$ Inductive Load (upper-lower arm)	-	1.20	1.90	2.60	μs
$t_{C(on)}$			-	0.50	0.80	μs	
t_{off}			-	2.60	3.60	μs	
$t_{C(off)}$			-	0.50	0.90	μs	
t_{rr}			-	0.50	-	μs	
I_{CES}	Collector-emitter cut-off current	$V_{CE}=V_{CES}$	$T_j= 25^\circ\text{C}$	-	-	1	mA
			$T_j= 125^\circ\text{C}$	-	-	10	

CONTROL (PROTECTION) PART

Symbol	Parameter	Condition	Limits			Unit	
			Min.	Typ.	Max.		
I_D	Circuit current	Total of $V_{P1}-V_{PC}$, $V_{N1}-V_{NC}$	$V_D=15\text{V}$, $V_{IN}=0\text{V}$	-	-	5.60	mA
			$V_D=15\text{V}$, $V_{IN}=5\text{V}$	-	-	5.60	
I_{DB}		Each part of $V_{UFB}-V_{UFS}$, $V_{VFB}-V_{VFS}$, $V_{WFB}-V_{WFS}$	$V_{DB}=15\text{V}$, $V_{IN}=0\text{V}$	-	-	1.10	
			$V_{DB}=15\text{V}$, $V_{IN}=5\text{V}$	-	-	1.10	
I_{SC}	Short circuit trip level	$-30^\circ\text{C}\leq T_j\leq 125^\circ\text{C}$, $R_s=48.7\Omega$ ($\pm 1\%$), Not connecting outer shunt resistors to NU, NV, NW terminals (Note 3)	59.5	-	-	A	
UV_{DBt}	P-side Control supply under-voltage protection(UV)	$T_j\leq 125^\circ\text{C}$	Trip level	10.0	-	12.0	V
UV_{DBr}			Reset level	10.5	-	12.5	V
UV_{Dt}	N-side Control supply under-voltage protection(UV)	$T_j\leq 125^\circ\text{C}$	Trip level	10.3	-	12.5	V
UV_{Dr}			Reset level	10.8	-	13.0	V
V_{FOH}	Fault output voltage	$V_{SC} = 0\text{V}$, F_O terminal pulled up to 5V by 10k Ω	4.9	-	-	V	
V_{FOL}		$V_{SC} = 1\text{V}$, $I_{FO} = 1\text{mA}$	-	-	0.95	V	
t_{FO}	Fault output pulse width	$C_{FO}=22\text{nF}$ (Note 4)	1.6	2.4	-	ms	
I_{IN}	Input current	$V_{IN} = 5\text{V}$	0.70	1.00	1.50	mA	
$V_{th(on)}$	ON threshold voltage	Applied between U_P , V_P , W_P , U_N , V_N , W_N-V_{NC}	-	-	3.5	V	
$V_{th(off)}$	OFF threshold voltage		0.8	-	-		
V_{OT}	Temperature output	LVIC temperature = 75°C (Note 5)	2.26	2.38	2.51	V	
V_F	Bootstrap Di forward voltage	$I_F=10\text{mA}$ including voltage drop by limiting resistor (Note 6)	0.5	0.9	1.3	V	
R	Built-in limiting resistance	Included in bootstrap Di	16	20	24	Ω	

Note 3: Short circuit protection detects sense current divided from main current at N-side IGBT and works for N-side IGBT only. In the case that outer shunt resistor is inserted into main current path, protection current level I_{SC} changes. For details, please refer the application note for this DIIPM.

4: Fault signal is output when short circuit or N-side control supply under-voltage protection works. The fault output pulse-width t_{FO} depends on the capacitance of C_{FO} . ($C_{FO}(\text{typ.}) = t_{FO} \times 9.1 \times 10^{-9}$) [F]

5: DIIPM doesn't shut down IGBTs and output fault signal automatically when temperature rises excessively. When temperature exceeds the protective level that user defined, controller (MCU) should stop immediately. Temperature of LVIC vs. V_{OT} output characteristics is described in Fig.3

6: The characteristics of bootstrap Di is described in Fig.2.

Fig. 2 Characteristics of bootstrap Di V_F-I_F curve (@ $T_a=25^\circ\text{C}$) including voltage drop by limiting resistor (Right chart is enlarged chart.)

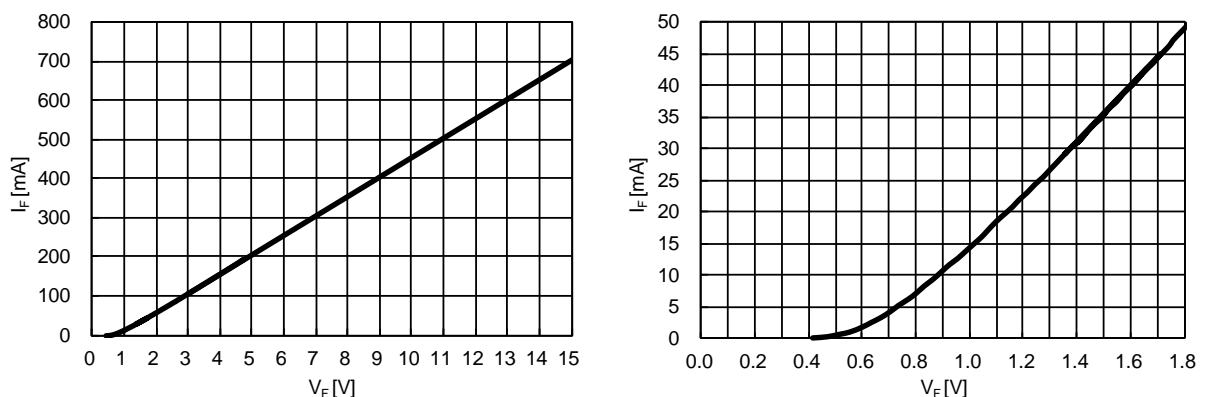
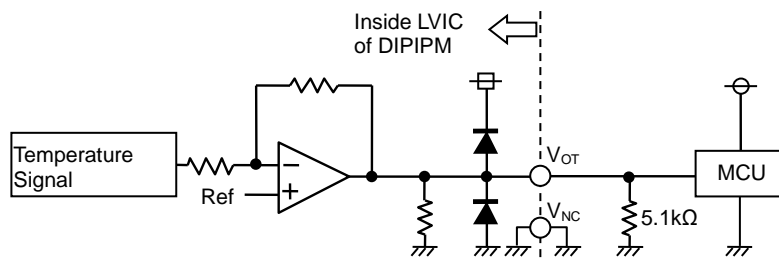
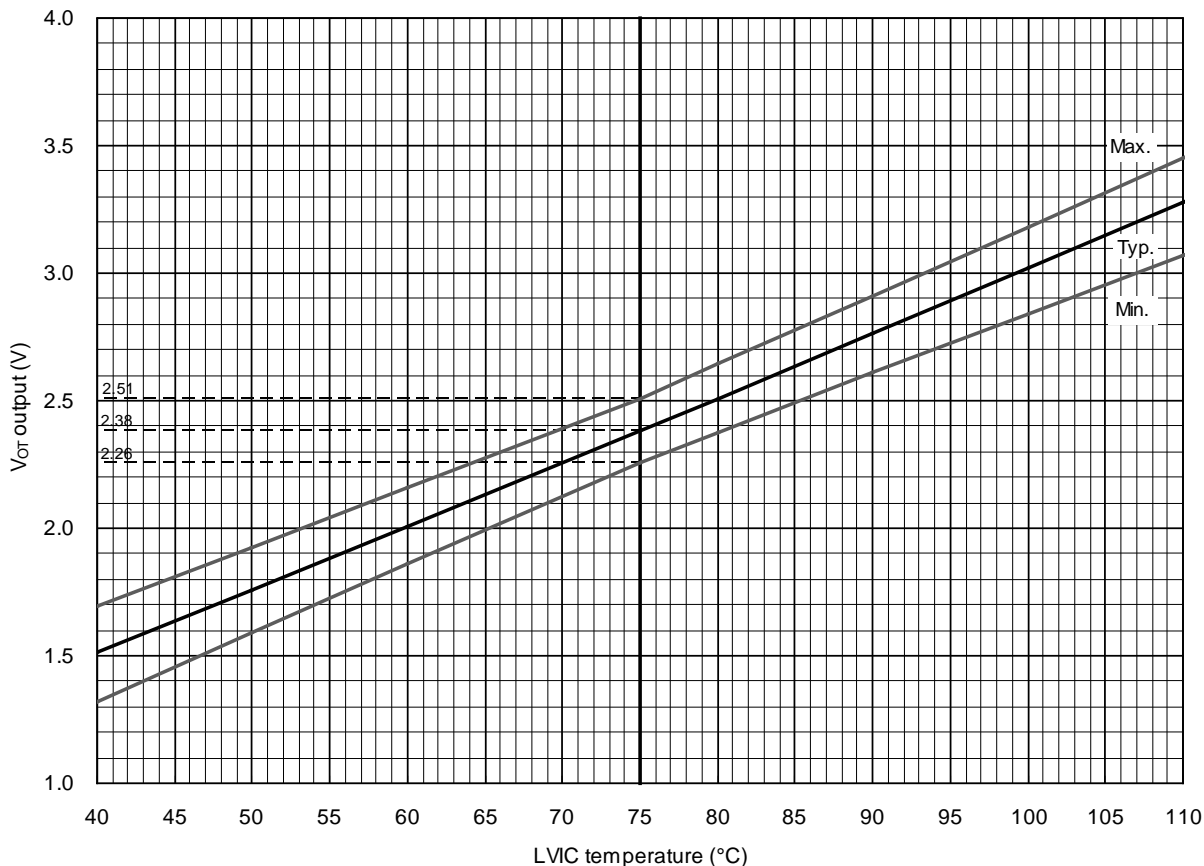

Fig. 3 Temperature of LVIC vs. V_{OT} Output Characteristics



- (1) It is recommended to insert 5.1kΩ pull down resistor for getting linear output characteristics at low temperature below room temperature. When the pull down resistor is inserted between V_{OT} and V_{NC} (control GND), the extra circuit current, which is calculated approximately by V_{OT} output voltage divided by pull down resistance, flows as LVIC circuit current continuously. In the case of using V_{OT} for detecting high temperature over room temperature only, it is unnecessary to insert the pull down resistor.
- (2) In the case of not using V_{OT} , leave V_{OT} output NC (No Connection).

Refer the application note for this product about the usage of V_{OT} .

PSS35SA2FT

TRANSFER MOLDING TYPE
INSULATED TYPE

MECHANICAL CHARACTERISTICS AND RATINGS

Parameter	Condition		Limits			Unit
			Min.	Typ.	Max.	
Mounting torque	Mounting screw : M4 (Note 7)	Recommended 1.18N·m	0.98	1.18	1.47	N·m
Terminal pulling strength	Load 19.6N	JEITA-ED-4701	10	-	-	s
Terminal bending strength	Load 9.8N, 90deg. bend	JEITA-ED-4701	2	-	-	times
Weight			-	46	-	g
Heat-sink flatness		(Note 8)	-50	-	100	μm

Note 7: Plain washers (ISO 7089-7094) are recommended.

Note 8: Measurement point of heat-sink flatness

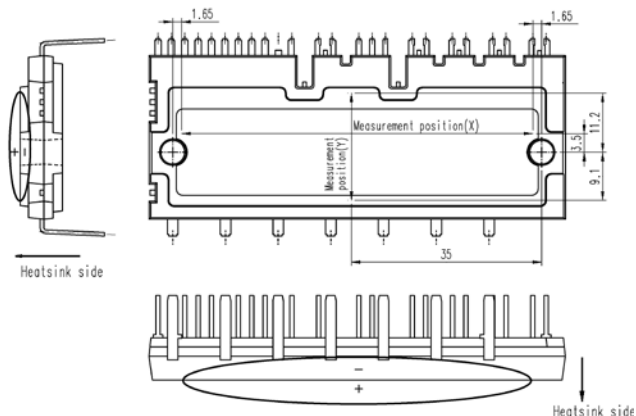

RECOMMENDED OPERATION CONDITIONS

Symbol	Parameter	Condition	Limits			Unit	
			Min.	Typ.	Max.		
V_{CC}	Supply voltage	Applied between P-NU, NV, NW	350	600	800	V	
V_D	Control supply voltage	Applied between $V_{P1}-V_{PC}$, $V_{N1}-V_{NC}$	13.5	15.0	16.5	V	
V_{DB}	Control supply voltage	Applied between $V_{UFB}-V_{UFS}$, $V_{VFB}-V_{VFS}$, $V_{WFB}-V_{WFS}$	13.0	15.0	18.5	V	
ΔV_D , ΔV_{DB}	Control supply variation		-1	-	+1	V/μs	
t_{dead}	Arm shoot-through blocking time	For each input signal	3.0	-	-	μs	
f_{PWM}	PWM input frequency	$T_C \leq 100^\circ C$, $T_j \leq 125^\circ C$	-	-	20	kHz	
I_o	Allowable r.m.s. current	$V_{CC} = 600V$, $V_D = 15V$, P.F = 0.8, Sinusoidal PWM $T_C \leq 100^\circ C$, $T_j \leq 125^\circ C$ (Note 9)	$f_{PWM} = 5kHz$	-	-	19.1	Arms
			$f_{PWM} = 15kHz$	-	-	12.8	
PWIN(on)	Minimum input pulse width	(Note 10)	1.5	-	-	μs	
PWIN(off)		$350 \leq V_{CC} \leq 800V$, $13.5 \leq V_D \leq 16.5V$, $13.0 \leq V_{DB} \leq 18.5V$, $-20^\circ C \leq T_C \leq 100^\circ C$, N line wiring inductance less than 10nH (Note 11)	$I_C \leq 35A$	3.0	-		-
			$35 < I_C \leq 59.5A$	3.5	-	-	
V_{NC}	V_{NC} variation	Between $V_{NC}-NU$, NV, NW (including surge)	-5.0	-	+5.0	V	
T_j	Junction temperature		-20	-	+125	°C	

Note 9: The allowable r.m.s. current value depends on the actual application conditions.

10: DIIPIM might not make response to the input on signal with pulse width less than PWIN (on).

11: IPM might make no response or delayed response (P-side IGBT only) for the input signal with off pulse width less than PWIN(off).

Please refer below figure about delayed response.

Fig. 4 About Delayed Response Against Shorter Input Off Signal Than PWIN(off) (P-side only)

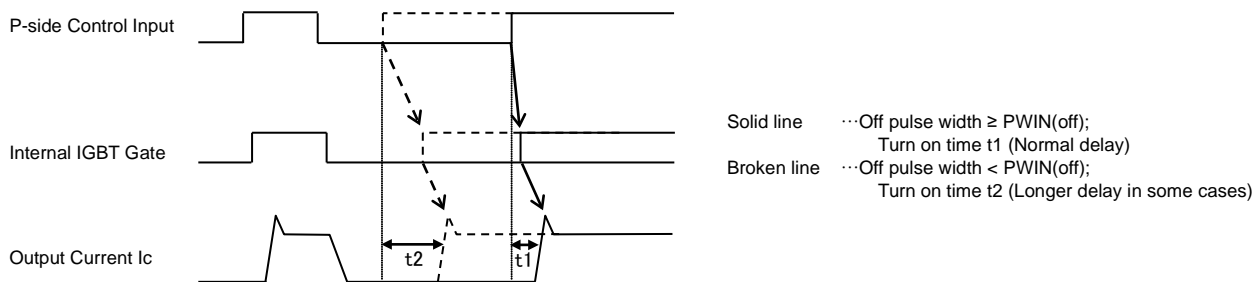

PSS35SA2FT

TRANSFER MOLDING TYPE
INSULATED TYPE

Fig. 5 Timing Charts of DIIPM Protective Functions

[A] Short-Circuit Protection (N-side only with the external sense resistor and RC filter)

- a1. Normal operation: IGBT ON and outputs current.
- a2. Short circuit current detection (SC trigger)
(It is recommended to set RC time constant 1.5~2.0 μ s so that IGBT shut down within 2.0 μ s when SC occurs.)
- a3. All N-side IGBT's gates are hard interrupted.
- a4. All N-side IGBTs turn OFF.
- a5. F_o outputs with a fixed pulse width determined by the external capacitor C_{FO} .
- a6. Input = "L": IGBT OFF
- a7. F_o finishes output, but IGBTs don't turn on until inputting next ON signal (L \rightarrow H).
- (IGBT of each phase can return to normal state by inputting ON signal to each phase.)
- a8. Normal operation: IGBT ON and outputs current.

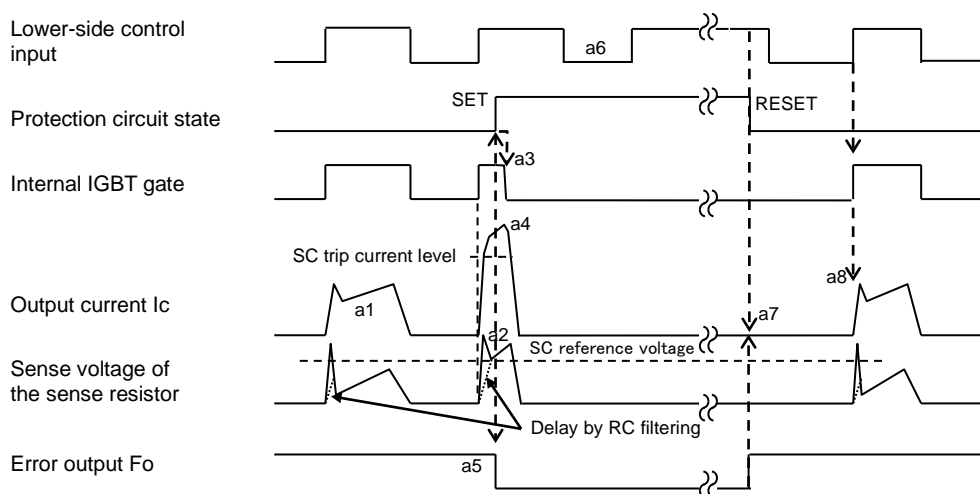

[B] Under-Voltage Protection (N-side, UV_D)

- b1. Control supply voltage V_D exceeds under voltage reset level (UV_{Dr}), but IGBT turns ON by next ON signal (L \rightarrow H).
(IGBT of each phase can return to normal state by inputting ON signal to each phase.)
- b2. Normal operation: IGBT ON and outputs current.
- b3. V_D level drops to under voltage trip level. (UV_{Dt}).
- b4. All N-side IGBTs turn OFF in spite of control input condition.
- b5. F_o outputs for the period determined by the capacitance C_{FO} , but output is extended during V_D keeps below UV_{Dr} .
- b6. V_D level reaches UV_{Dr} .
- b7. Normal operation: IGBT ON and outputs current by next ON signal (L \rightarrow H).

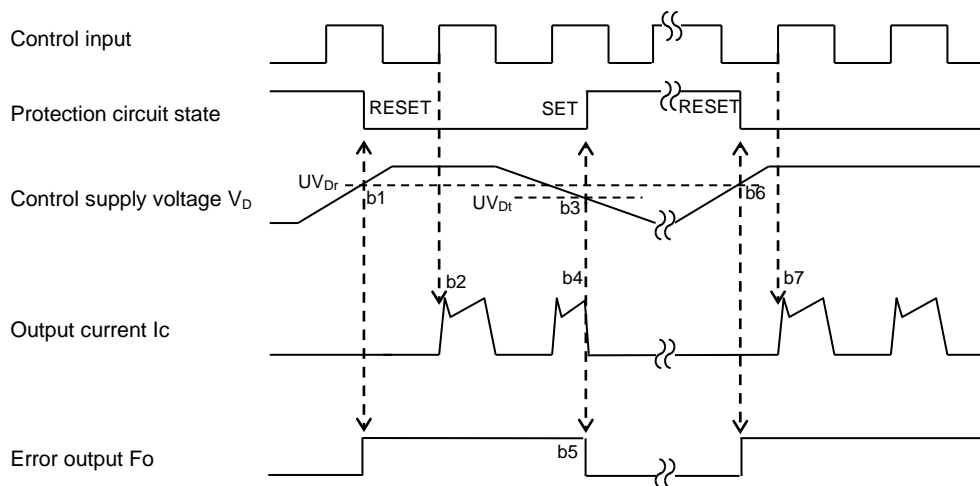

PSS35SA2FT

TRANSFER MOLDING TYPE
INSULATED TYPE

[C] Under-Voltage Protection (P-side, UV_{DB})

- c1. Control supply voltage V_{DB} rises. After the voltage reaches under voltage reset level UV_{DBr} , IGBT turns on by next ON signal (L→H).
- c2. Normal operation: IGBT ON and outputs current.
- c3. V_{DB} level drops to under voltage trip level (UV_{DBt}).
- c4. IGBT of corresponding phase only turns OFF in spite of control input signal level, but there is no F_o signal output.
- c5. V_{DB} level reaches UV_{DBr} .
- c6. Normal operation: IGBT ON and outputs current by next ON signal (L→H).

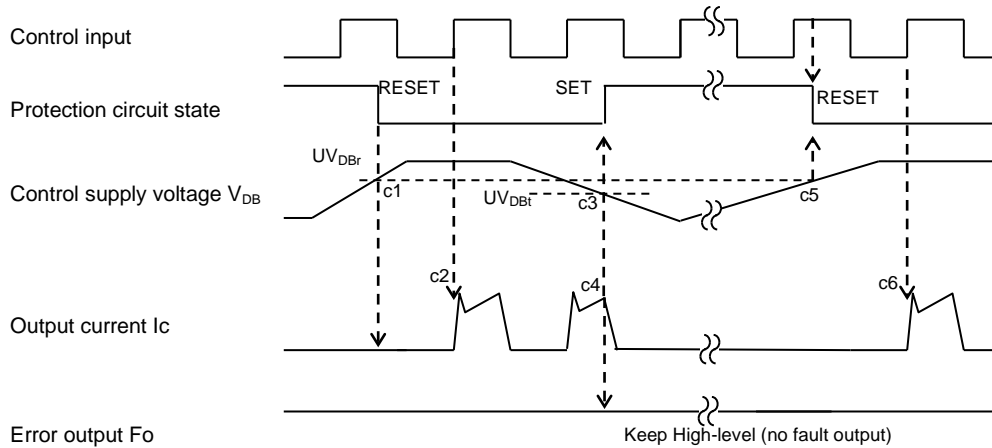
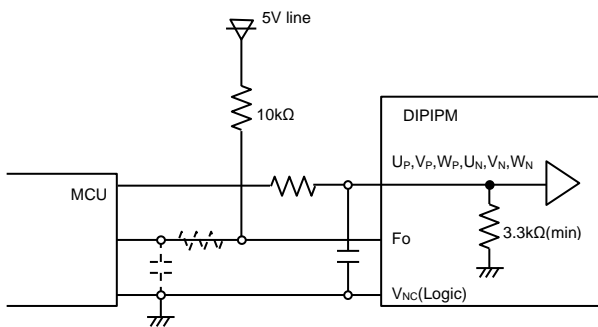

Fig. 6 MCU I/O Interface Circuit



Note)

Design for input RC filter depends on the PWM control scheme used in the application and the wiring impedance of the printed circuit board. But because noisier in the application for 1200V, it is strongly recommended to insert RC filter. (Time constant: over 100ns. e.g. 100Ω, 1000pF) The DIIPM input signal interface integrates a min. 3.3kΩ pull-down resistor. Therefore, when using RC filter, be careful to satisfy turn-on threshold voltage requirement.

F_o output is open drain type. It should be pulled up to the positive side of 5V or 15V power supply with the resistor that limits F_o sink current I_{F_o} under 1mA. In the case of pulling up to 5V supply, over 5.1kΩ is needed. (10kΩ is recommended.)

Fig. 7 Wiring Pattern around the Shunt Resistor in the Case of Inserting into Main Current Path

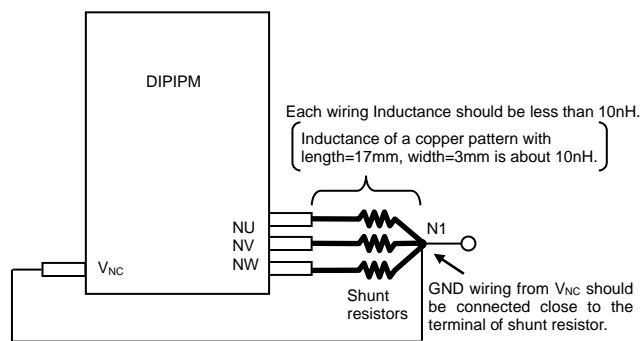

Low inductance shunt resistor like surface mounted (SMD) type is recommended. Protection current level I_{sc} changes by inserting shunt resistor.

PSS35SA2FT

TRANSFER MOLDING TYPE
INSULATED TYPE

Fig. 8 Example of Application Circuit

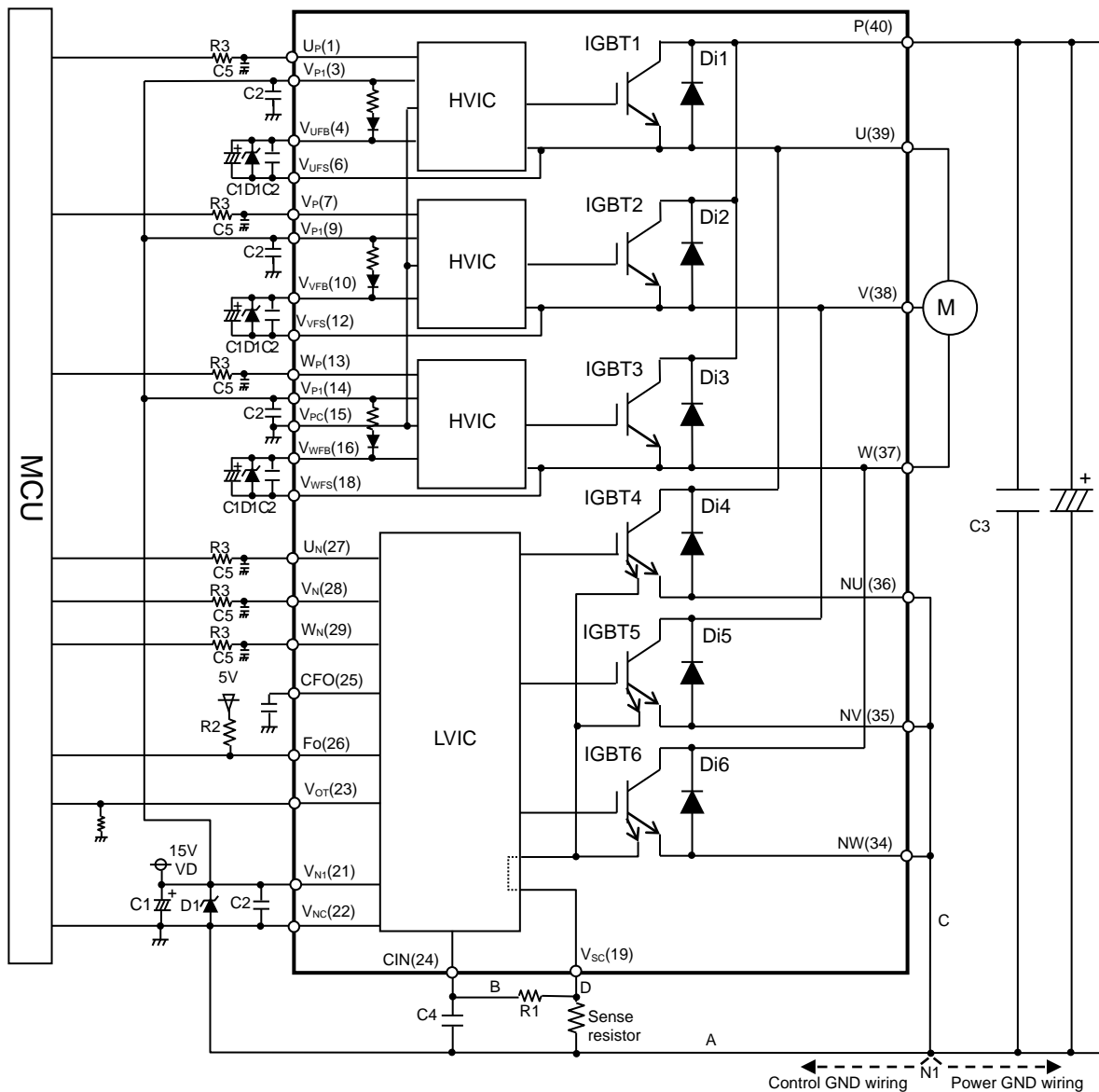

Note

- 1 :If control GND and power GND are patterned by common wiring, it may cause malfunction by fluctuation of power GND level. It is recommended to connect control GND and power GND at only a N1 point at which NU, NV, NW are connected to power GND line.
- 2 :It is recommended to insert a Zener diode D1 (24V/1W) between each pair of control supply terminals to prevent surge destruction.
- 3 :To prevent surge destruction, the wiring between the smoothing capacitor and the P, N1 terminals should be as short as possible. Generally inserting a 0.1 μ ~0.22 μ F snubber capacitor C3 between the P-N1 terminals is recommended.
- 4 :R1, C4 of RC filter for preventing protection circuit malfunction is recommended to select tight tolerance, temp-compensated type. The time constant R1C4 should be set so that SC current is shut down within 2 μ s. (1.5 μ s~2 μ s is general value.) SC interrupting time might vary with the wiring pattern, so the enough evaluation on the real system is recommended. If R1 is too small, it may leads to delay of protection. So R1 should be min. 10 times larger resistance than Rs. (100 times is recommended.)
- 5 :To prevent erroneous operation, the wiring of A, B, C should be as short as possible.
- 6 :For sense resistor, the variation within 1%(including temperature characteristics), low inductance type is recommended. And the over 0.03W is recommended, but it is necessary to evaluate in your real system finally.
- 7 :To prevent erroneous SC protection, the wiring from Vsc terminal to CIN filter should be divided at the point D that is close to the terminal of sense resistor. And the wiring should be patterned as short as possible.
- 8 :All capacitors should be mounted as close to the terminals of the DIIPM as possible. (C1: good temperature, frequency characteristic electrolytic type, and C2: 0.01 μ ~2.0 μ F, good temperature, frequency and DC bias characteristic ceramic type are recommended.)
- 9 :Input drive is High-active type. There is a min. 3.3k Ω pull-down resistor in the input circuit of IC. To prevent malfunction, the wiring of each input should be as short as possible. And it is recommended to insert RC filter (e.g. R3=100 Ω and C5=1000pF) and confirm the input signal level to meet the turn-on and turn-off threshold voltage. Thanks to HVIC inside the module, direct coupling to MCU without any opto-coupler or transformer isolation is possible.
- 10 :Fo output is open drain type. Fo output will be max 0.95V (@IfO=1mA, 25 $^{\circ}$ C), so it should be pulled up to MCU or control power supply (e.g. 5V, 15V) by a resistor that makes IfO up to 1mA. (In the case of pulled up to 5V, 10k Ω is recommended.)
- 11 :Error signal output width (tFo) can be set by the capacitor connected to CFo terminal. $C_{Fo}(typ.) = t_{Fo} \times 9.1 \times 10^{-6} (F)$
- 12 :If high frequency noise superimposed to the control supply line, IC malfunction might happen and cause erroneous operation. To avoid such problem, voltage ripple of control supply line should meet $dV/dt \leq \pm 1V/\mu s$, $V_{ripple} \leq 2V_{p-p}$.
- 13 :For DIIPM, it isn't recommended to drive same load by parallel connection with other phase IGBT or other DIIPM.

PSS35SA2FT

TRANSFER MOLDING TYPE
INSULATED TYPE

Fig. 9 Package Outlines

Dimensions in mm

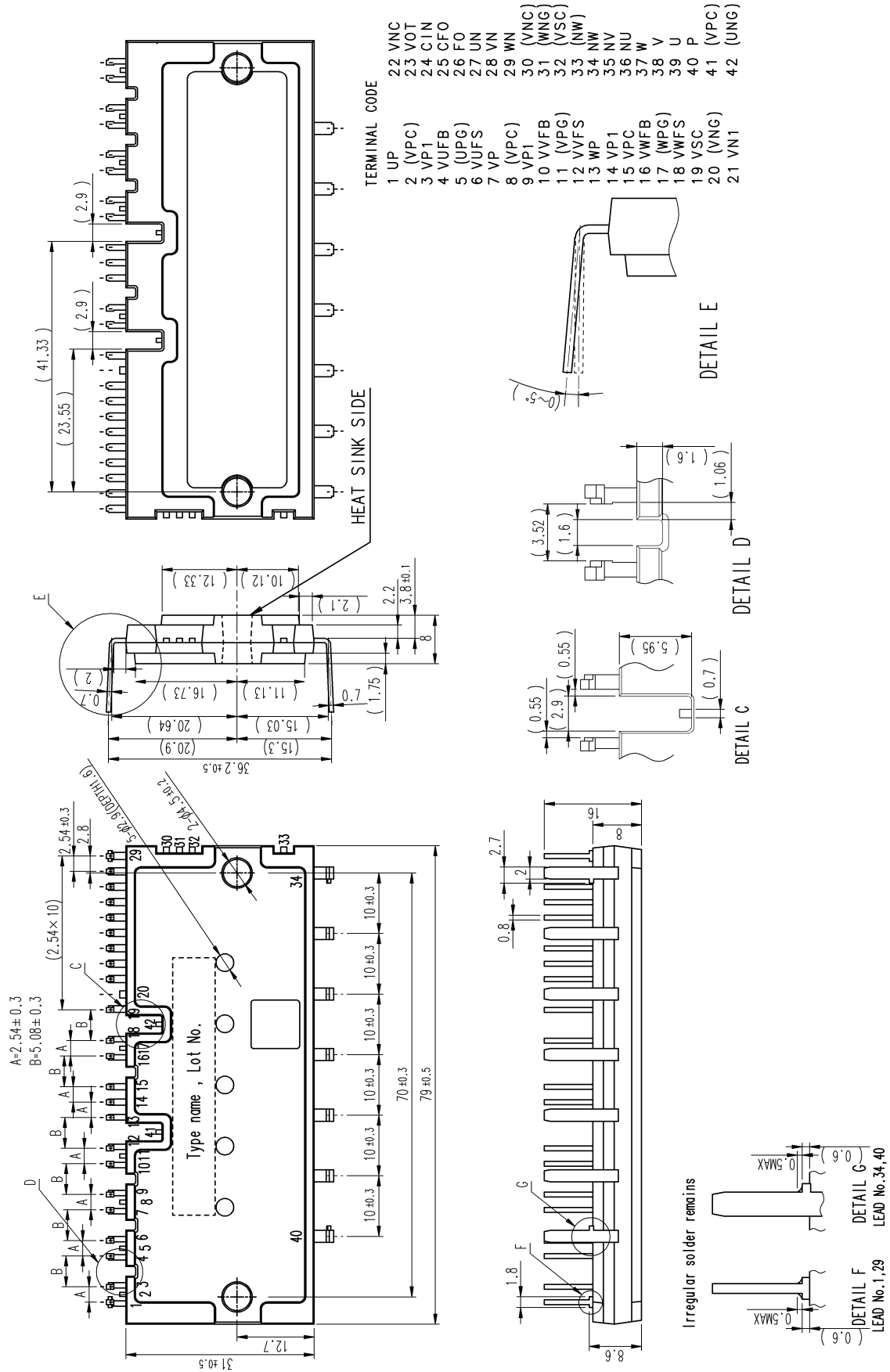

Important Notice

The information contained in this datasheet shall in no event be regarded as a guarantee of conditions or characteristics. This product has to be used within its specified maximum ratings, and is subject to customer's compliance with any applicable legal requirement, norms and standards.

Except as otherwise explicitly approved by Mitsubishi Electric Corporation in a written document signed by authorized representatives of Mitsubishi Electric Corporation, our products may not be used in any applications where a failure of the product or any consequences of the use thereof can reasonably be expected to result in personal injury.

In usage of power semiconductor, there is always the possibility that trouble may occur with them by the reliability lifetime such as Power Cycle, Thermal Cycle or others, or when used under special circumstances (e.g. condensation, high humidity, dusty, salty, highlands, environment with lots of organic matter / corrosive gas / explosive gas, or situations which terminals of semiconductor products receive strong mechanical stress). Therefore, please pay sufficient attention to such circumstances. Further, depending on the technical requirements, our semiconductor products may contain environmental regulation substances, etc. If there is necessity of detailed confirmation, please contact our nearest sales branch or distributor.

The contents or data contained in this datasheet are exclusively intended for technically trained staff. Customer's technical departments should take responsibility to evaluate the suitability of Mitsubishi Electric Corporation product for the intended application and the completeness of the product data with respect to such application. In the customer's research and development, please evaluate it not only with a single semiconductor product but also in the entire system, and judge whether it's applicable. As required, pay close attention to the safety design by installing appropriate fuse or circuit breaker between a power supply and semiconductor products to prevent secondary damage. Please also pay attention to the application note and the related technical information.

Keep safety first in your circuit designs!

Mitsubishi Electric Corporation puts the maximum effort into making semiconductor products better and more reliable, but there is always the possibility that trouble may occur with them. Trouble with semiconductors may lead to personal injury, fire or property damage. Remember to give due consideration to safety when making your circuit designs, with appropriate measures such as (i) placement of substitutive, auxiliary circuits, (ii) use of non-flammable material or (iii) prevention against any malfunction or mishap.

Notes regarding these materials

- These materials are intended as a reference to assist our customers in the selection of the Mitsubishi Electric Semiconductor product best suited to the customer's application; they do not convey any license under any intellectual property rights, or any other rights, belonging to Mitsubishi Electric Corporation or a third party.
- Mitsubishi Electric Corporation assumes no responsibility for any damage, or infringement of any third-party's rights, originating in the use of any product data, diagrams, charts, programs, algorithms, or circuit application examples contained in these materials.
- All information contained in these materials, including product data, diagrams, charts, programs and algorithms represents information on products at the time of publication of these materials, and are subject to change by Mitsubishi Electric Corporation without notice due to product improvements or other reasons. It is therefore recommended that customers contact Mitsubishi Electric Corporation or an authorized Mitsubishi Electric Semiconductor product distributor for the latest product information before purchasing a product listed herein.
The information described here may contain technical inaccuracies or typographical errors. Mitsubishi Electric Corporation assumes no responsibility for any damage, liability, or other loss rising from these inaccuracies or errors.
Please also pay attention to information published by Mitsubishi Electric Corporation by various means, including the Mitsubishi Electric Semiconductor home page (<http://www.MitsubishiElectric.com/semiconductors/>).
- When using any or all of the information contained in these materials, including product data, diagrams, charts, programs, and algorithms, please be sure to evaluate all information as a total system before making a final decision on the applicability of the information and products. Mitsubishi Electric Corporation assumes no responsibility for any damage, liability or other loss resulting from the information contained herein.
- Mitsubishi Electric Corporation semiconductors are not designed or manufactured for use in a device or system that is used under circumstances in which human life is potentially at stake. Please contact Mitsubishi Electric Corporation or an authorized Mitsubishi Electric Semiconductor product distributor when considering the use of a product contained herein for any specific purposes, such as apparatus or systems for transportation, vehicular, medical, aerospace, nuclear, or undersea repeater use.
- The prior written approval of Mitsubishi Electric Corporation is necessary to reprint or reproduce in whole or in part these materials.
- If these products or technologies are subject to the Japanese export control restrictions, they must be exported under a license from the Japanese government and cannot be imported into a country other than the approved destination.
Any diversion or re-export contrary to the export control laws and regulations of Japan and/or the country of destination is prohibited.
- Please contact Mitsubishi Electric Corporation or an authorized Mitsubishi Electric Semiconductor product distributor for further details on these materials or the products contained therein.