

FOR IMMEDIATE RELEASE

No. 3492

Customer Inquiries

Media Inquiries

Industrial Automation Machinery Dept.
Industrial Automation Machinery Marketing Division
Mitsubishi Electric Corporation

Public Relations Division
Mitsubishi Electric Corporation

www.MitsubishiElectric.com/

prd.gnews@nk.MitsubishiElectric.co.jp
www.MitsubishiElectric.com/news/

Mitsubishi Electric to Launch Digital Wire-laser Metal 3D Printer

Contributes to manufacturing in a decarbonized era with a world's first for digital 3D printing technology

TOKYO, February 24, 2022 – [Mitsubishi Electric Corporation](https://www.mitsubishielectric.com) (TOKYO: 6503) announced today that on March 1 it will release two models of the “AZ600” wire-laser metal 3D printer, which melts welding wire with a laser beam to create high-quality 3D structures. Digital additive-manufacturing technology combined with simultaneous 5-axis spatial control and coordinated control of machining conditions, a world’s first*, delivers stable, high-quality 3D printing. Furthermore, it contributes to manufacturing in a decarbonized era by reducing energy consumption, saves resources by shortening of processing time and using highly efficient production methods such as ‘near-net-shape’, and supports the build-up of repairs for the maintenance of specialist parts for automobiles, ships and aircraft. Additionally, a new contract printing service utilizing these printers will help the adoption of additive manufacturing by offering product design consultation, prototyping and general advice about the application of 3D metal printing.

In recent years, the growing need to reduce CO₂ emissions in the metalworking manufacturing industry has stimulated an increase in demand for more efficient metalworking methods that reduce energy consumption and conserve finite natural resources. In particular, demand is expected to grow for metal 3D printers, which create objects from 3D shape data. This has the advantages of significantly shortening the conventional manufacturing process, reducing waste materials in the manufacturing process, and improving design flexibility by making it easier to integrate multiple parts and reduce weight. On the other hand, metal 3D printers that use powder-based feedstock have issues with material management, workability and safety, and a new additive manufacturing process has been required.

To solve the problems with powder-based printers, Mitsubishi Electric is now launching the AZ600, a world's first* wire-laser metal 3D printer that combines simultaneous 5-axis spatial control and digital additive-manufacturing technology that precisely and cooperatively controls processing conditions. This product realizes high-quality, high-precision 3D printing and contributes to manufacturing that considers its environmental impact by reducing energy consumption and waste.

The “AZ600” will be exhibited at the “Additive Manufacturing Expo” from March 16-18 at Tokyo Big Sight.

* As of February 24, 2022, according to Mitsubishi Electric’s research



Wire-laser metal 3D printer “AZ600”

Overview of Release

Product name	Model	Oscillator	Release	Sales target
Wire-laser metal 3D printer “AZ600”	AZ600-F20	2kW	March 1	100 machines (annually)
	AZ600-F40	4kW		

Product Features

1) Unprecedented digital 3D printing technology for stable, high-quality additive manufacturing

Conventional metal 3D printers use either powder or wire feedstocks. Powder feedstock is suitable for complex, high-precision builds, but incurs problems with material storage, environmental impact and material costs. Wire feedstock typically uses an arc discharge as its heat source, which entails problems with accuracy due to high thermal strain and the impact of heat on material layers.

Mitsubishi Electric’s new wire-feedstock method solves these problems by using a laser beam for highly precise control of heat input according to the build state, thereby combining molding accuracy with the advantages of wire feedstock. The unique use of computerized numerical controller (CNC), for the cooperative control of processing conditions such as wire feeding, laser power and axis feed, now makes it possible for additive manufacturing of high-precision and high-quality three-dimensional structures.

By optimizing the control of axis command values, wire feed amount and laser-power command values based on sensor data of the build state, a highly stable build process is realized for high-quality 3D printing.

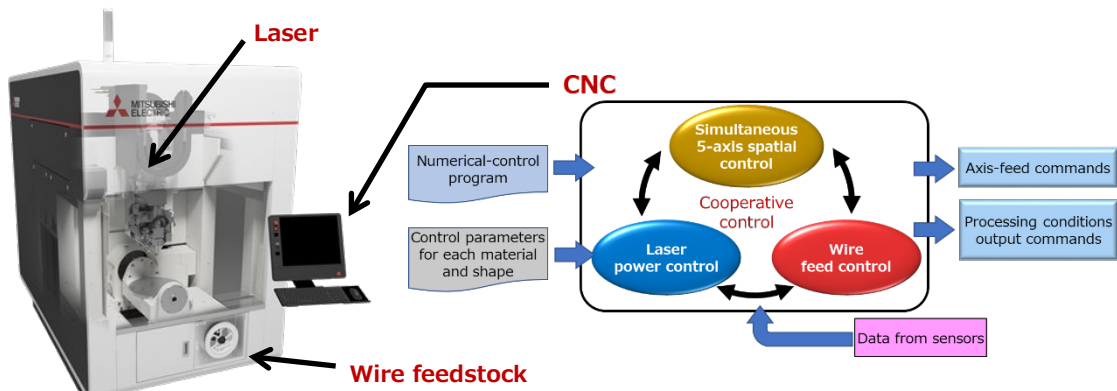

Cooperative control of build conditions and axis feed

In addition, applying digital printing technology to control the laser beam intensity/power and wire feed with dedicated computer-aided manufacturing (CAM) for print path generation allows build conditions to be optimized according to specific three-dimensional structures, using dot or continuous forming.

Furthermore, using consistent-quality wire-feedstock materials contribute to high-quality metal forming for high-density builds with few voids. Complex 3D structures, which are difficult to realize using an arc heat source, can be formed with high accuracy using Mitsubishi Electric’s unique high-precision heat control technology. It is also possible to create hollow spheres, which are, in principle, impossible to be created by traditional cutting techniques.

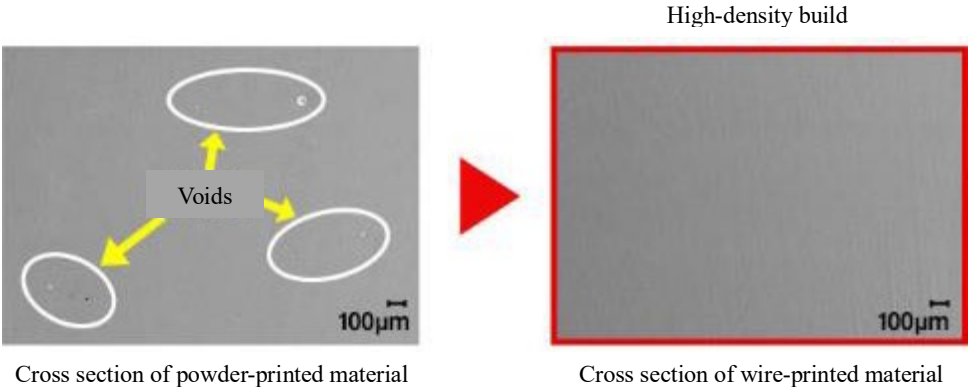

Example of hollow ball build



Example of using a 3D scanner

2) Simultaneous 5-axis spatial control and new processing technology for speed, resource and labor savings

The near-net-shape method, in which a near-finished shape is formed in a short time and then finished by cutting, can shorten machining time and reduce waste materials compared to conventional methods which use cutting for all processes from roughing to finishing. In the test production of a marine propeller with a 300mm diameter, the near-net-shape method reduced machining time and waste materials by approximately 80% compared to conventional methods that require final grinding of the overall object. This method can contribute to energy and resource savings.

Moreover, additive manufacturing can be used as part of the repair and maintenance of expensive consumable parts, especially those used in harsh environments such as turbine blades or molds, as it can extend the lifetime and reduce the running costs associated with those parts.

Furthermore, utilizing advanced simultaneous 5-axis spatial control means highly skilled traditional manual processes for buildup welding and groove welding, using materials like Tungsten Inert Gas (TIG), can now be performed by metal 3D printing to improve build quality, shorten build time, and save labor.



Example of 300mm diameter propeller for a boat, which achieves the reduction of both processing time and waste material by about 80%



Example of welding



Example of build-up welding suitable for repair work

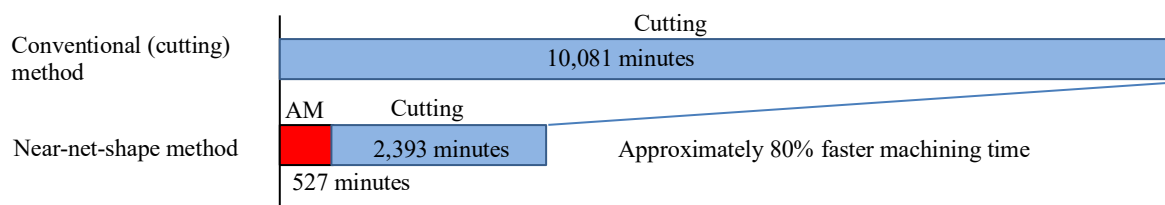

Main Specifications

Model	AZ600-F20	AZ600-F40
Process category	Directed energy deposition (DED)	
Stroke (X×Y×Z) (mm)	600×600×600	
Maximum workpiece dimensions (mm)	Φ500×500	
Maximum load workpiece weight (kg)	500	
Machine weight (kg)	7000	
External Dimensions (W×D×H; mm)	1600×2900×2500	
Numerical controller model	M850	
Main features	Height sensor, shield-gas numerical control, monitoring camera	
Key options	AC-axis specifications & automatic slide doors (sides and ceiling)	

Contribution to Environment

The new wire-laser metal 3D printer lowers the environmental impact of production operations and supports sustainability by extending production equipment life and avoiding production waste.

###

About Mitsubishi Electric Corporation

With 100 years of experience in providing reliable, high-quality products, Mitsubishi Electric Corporation (TOKYO: 6503) is a recognized world leader in the manufacture, marketing and sales of electrical and electronic equipment used in information processing and communications, space development and satellite communications, consumer electronics, industrial technology, energy, transportation and building equipment. Mitsubishi Electric enriches society with technology in the spirit of its “Changes for the Better.” The company recorded a revenue of 4,191.4 billion yen (U.S.\$ 37.8 billion*) in the fiscal year ended March 31, 2021. For more information, please visit www.MitsubishiElectric.com

*U.S. dollar amounts are translated from yen at the rate of ¥111=U.S.\$1, the approximate rate on the Tokyo Foreign Exchange Market on March 31, 2021